



Water Department

**Water System  
Standard Specifications**

December 2009 Revision

◆ Section 1

**Technical Specifications**

◆ Section 2

**Material Specifications**

◆ Section 3

**Standard Details**



City of Santa Cruz  
Water Department Engineering  
212 Locust Street, Suite C  
Santa Cruz, California

# Table of Contents

<b>SECTION 1 TECHNICAL SPECIFICATIONS.....</b>	<b>1</b>
1 General Provisions .....	1
1.1 General .....	1
1.2 Scope .....	1
1.3 Definitions .....	1
1.4 Abbreviations .....	2
1.5 Specification References .....	3
1.6 Standard Details.....	3
1.7 Water System Plans.....	3
1.8 Development Plan Submittal Requirements .....	3
1.9 Submittals .....	4
1.10 Permitting Requirements.....	4
1.11 Licenses .....	4
1.12 Rights-of-Way .....	4
1.13 Inspection.....	4
1.14 Advance Notification and Scheduling .....	4
1.15 Authority of Engineer.....	5
1.16 Guarantee and Warranty Period .....	5
1.17 Lines, Grades, and Alignments.....	5
1.18 Separation Requirements .....	5
1.18.1 Separation from Non Potable Lines and Hazardous Facilities.....	5
1.18.2 Separation From Trees.....	6
2 Site Conditions.....	7
2.1 Site Safety.....	7
2.2 Traffic Control and Site Access.....	7
2.2.1 Control Devices .....	8
2.2.2 Pedestrian Bridges .....	8
2.2.3 Site Access During Working Hours .....	8
2.2.4 Site Access During Non-working Hours .....	8
2.3 Site Cleanliness .....	9
2.4 Site Restoration.....	9
2.5 Dust Control .....	9
2.6 Water Pollution Control .....	9
2.7 Discovery of Archaeological Resources .....	10
3 Excavation .....	12
3.1 General .....	12
3.2 Protection of Existing Facilities .....	12
3.2.1 Proper Precautions to Avoid Damage to Facilities.....	12
3.2.2 Repairs to Damaged Facilities.....	13
3.3 Saw Cutting and Pavement Removal .....	13
3.4 Trench Excavation .....	13
3.5 Trench Base Preparation .....	14
3.6 Bell Holes.....	14
3.7 Blasting .....	14

3.8	Bracing and Shoring.....	14
3.9	Disposal of Excavated Materials.....	15
4	Installation of DI and PVC Pipe .....	16
4.1	General .....	16
4.2	Handling of Pipe and Accessories .....	16
4.3	Laying Pipe .....	16
4.3.1	Cleanliness .....	16
4.3.2	Unsuitable Conditions for Laying Pipe.....	16
4.3.3	Direction of Laying .....	16
4.3.4	Polyethylene Encasement .....	16
4.4	Joints for Pipe and Fittings.....	17
4.4.1	Cutting Pipe .....	17
4.4.2	Cleaning Joint Surfaces.....	17
4.4.3	Permissible Deflection at Joints.....	17
4.4.4	Joint Types .....	17
4.4.5	Restrained Joints .....	17
4.5	Miscellaneous .....	18
5	Installation of Steel Pipe .....	19
5.1	General .....	19
5.2	Handling of Pipe.....	19
5.3	Laying Pipe .....	19
5.4	Field Joints .....	19
5.5	Field Alterations and System Connections .....	19
5.6	Welding .....	20
5.7	Miscellaneous .....	20
6	Installation of Appurtenances .....	21
6.1	Hot Tap Connections .....	21
6.1.1	Tap Location .....	21
6.1.2	Tap Installation .....	21
6.1.3	Use of Purge Valve.....	21
6.1.4	Polyethylene Encasement .....	21
6.2	Installation of Valves .....	21
6.2.1	Valve Box Installation .....	22
6.2.2	Valve Box Adjustment.....	22
6.3	Installation of Blow-Offs .....	22
6.4	Air Valve Installation.....	23
6.5	Fire Hydrants.....	23
6.5.1	Fire Hydrant Location Requirements.....	23
6.5.2	Fire Hydrant Installation.....	24
6.5.3	Fire Hydrant Relocation.....	24
6.6	Flexible Couplings and Repair Clamps.....	24
6.7	Water Services.....	25
6.7.1	Service Lateral Installation .....	25
6.7.2	Disinfection .....	26
6.7.3	Meter Box Installation .....	26
6.7.4	Radio Read Conduit .....	26
6.7.5	Meter Box Relocation or Service Retrofit .....	26
6.8	Installation of Backflow Prevention Assemblies.....	26
6.8.1	Location .....	27
6.8.2	Assemblies .....	27
6.8.3	Protective Cover or Cage .....	27
6.9	Pipe Location Wire.....	27
6.10	Chlorination Tap.....	28

6.11	Pressure Regulating Station .....	28
6.12	Sample Station .....	28
6.13	Appurtenant Concrete Work .....	28
6.13.1	Thrust Blocks and Reverse Anchors .....	28
6.13.2	Fire Hydrant and Backflow Prevention Device Concrete Pads .....	29
6.14	Traffic Bollard Installation.....	29
7	Backfill and Paving .....	30
7.1	General .....	30
7.2	Backfill.....	30
7.2.1	Backfill Placement .....	30
7.2.2	Compaction Methods.....	31
7.2.3	Compaction Testing.....	31
7.3	Paving .....	31
7.3.1	Asphalt Concrete Paving .....	32
7.3.2	Portland Cement Concrete Paving.....	32
8	Removal and Abandonment .....	33
8.1	Valves.....	33
8.1.1	Valve Removal.....	33
8.1.2	Valve Abandonment .....	33
8.2	Pipeline Abandonment .....	33
8.3	Fire Hydrant Removal .....	33
8.4	Service Abandonment.....	34
9	Pressure and Leakage Testing.....	35
9.1	Pressure and Leakage Tests .....	35
9.2	Pressure Test Procedure .....	35
9.3	Leakage Test Procedure.....	35
9.4	Test Failure .....	36
10	Disinfection and Testing .....	37
10.1	General .....	37
10.2	Disinfection of Mains .....	37
10.3	Disinfection of Services.....	37
10.3.1	Chlorination of New Pipelines.....	37
10.3.2	Urgent Disinfection .....	37
10.4	Disinfection Testing.....	38
10.4.1	Special Additional Testing Requirements.....	38
10.5	Contractor's Responsibility for Disinfection and Testing.....	39
11	Work on the Existing System.....	40
11.1	Advance Notice of Shut Down .....	40
11.2	Operation of the Existing System.....	40
11.3	Preparation.....	40
11.4	Dewatering Operations .....	40
11.5	Leakage Inspection .....	41
11.6	Tie-Ins .....	41
11.6.1	Connection Procedure.....	41

**SECTION 2 MATERIAL SPECIFICATIONS..... 42**

- 1 General..... 42
  - 1.1 Scope..... 42
  - 1.2 General ..... 42
  - 1.3 Pre Approved Products..... 42
- 2 Pipe..... 43
  - 2.1 Brass Pipe..... 43
    - 2.1.1 Joints..... 43
  - 2.2 Copper Pipe ..... 43
    - 2.2.1 Joints..... 43
  - 2.3 Ductile Iron Pipe..... 43
    - 2.3.1 Interior Lining..... 43
    - 2.3.2 Exterior Coating..... 43
    - 2.3.3 Polyethylene Encasement..... 43
    - 2.3.4 Joints..... 44
  - 2.4 Polyvinyl Chloride Pipe ..... 44
    - 2.4.1 Joints..... 44
  - 2.5 Welded Steel Pipe..... 44
    - 2.5.1 Interior Lining..... 45
    - 2.5.2 Exterior Coating..... 45
    - 2.5.3 Joints..... 45
- 3 Fittings ..... 46
  - 3.1 Bolted Sleeve Couplings (Flex Couplings)..... 46
    - 3.1.1 Interior/Exterior Coating..... 46
  - 3.2 Brass Fittings ..... 46
    - 3.2.1 Joints..... 46
  - 3.3 Ductile Iron Fittings ..... 46
    - 3.3.1 Interior Lining..... 47
    - 3.3.2 Exterior Coating..... 47
    - 3.3.3 Joints..... 47
  - 3.4 Welded Steel Fittings ..... 47
- 4 Joint Restraints ..... 48
  - 4.1 Joint Restraints for DI Push-On Joints..... 48
  - 4.2 Joint Restraints for Mechanical Joints with DI Pipe..... 48
  - 4.3 Joint Restraints for Mechanical Joints with PVC Pipe..... 48
  - 4.4 Joint Restraints for PVC Push-On Joints..... 49
- 5 Valves ..... 50
  - 5.1 Air Valves ..... 50
    - 5.1.1 Vacuum Relief Valve ..... 50
    - 5.1.2 Air Release Valves ..... 50
    - 5.1.3 Combination Air Valves ..... 50
  - 5.2 Backflow Prevention Assemblies ..... 50
  - 5.3 Brass Valves ..... 50
    - 5.3.1 2 Inch Fire Service Gate Valves..... 51
    - 5.3.2 Angle Meter Stops..... 51
    - 5.3.3 Corporation Stops..... 51
  - 5.4 Check Valves ..... 51
    - 5.4.1 Meter Check Valve ..... 51

5.4.2	Backflow Devices.....	51
5.5	Fire Hydrants.....	52
5.5.1	Hydrant Head.....	52
5.5.2	Hydrant Bury.....	52
5.5.3	Break Away Features .....	52
5.6	Main Line Valves.....	52
5.6.1	Interior/Exterior Coating.....	53
5.6.2	Joints.....	53
6	Appurtenances.....	54
6.1	Boxes and Lids.....	54
6.1.1	Non Traffic Rated Meter Boxes .....	54
6.1.2	Traffic Rated Meter Boxes .....	54
6.1.3	Valve Boxes.....	54
6.2	Aboveground Enclosures.....	54
6.2.1	Air Valve Enclosures.....	54
6.2.2	Aboveground Meter Enclosures .....	55
6.3	Radio Read Conduit.....	55
6.4	Repair Clamps .....	55
6.5	Tapping Saddles and Tapping Sleeves .....	55
6.5.1	Tapping Sleeves for Steel Water Mains .....	55
6.5.2	Tapping Saddles for PVC Water Mains.....	56
6.5.3	Tapping Saddles for A-C and CI Water Mains .....	56
6.5.4	Tapping Saddles for DI Mains .....	56
6.6	Wrapping Tape.....	56
6.7	Wood Blocking & Posts.....	56
7	Backfill & Pavement.....	57
7.1	Backfill Material .....	57
7.1.1	Sand.....	57
7.1.2	Aggregate Base .....	57
7.1.3	CLSM.....	57
7.2	Pavement.....	57
7.2.1	Asphalt Concrete .....	57
7.2.2	Portland Cement Concrete .....	58
7.2.3	Concrete Reinforcement.....	58
8	Miscellaneous.....	59
8.1	Disinfection Materials.....	59
8.2	Temporary Materials .....	59

<b>SECTION 3 STANDARD DETAILS .....</b>	<b>60</b>
Index and Abbreviations .....	61
Detail 1 - Service Connection .....	62
Detail 2 - Meter Box Installation.....	63
Detail 3 - 1-inch and Smaller Multiple Branched Service Installation.....	64
Detail 4 - Combination 2-inch Fire and Domestic Service Installation .....	65
Detail 5 - 2-inch and Smaller Service Installation.....	66
Detail 6 - 3-inch or 4-inch Service Installation .....	67
Detail 7 - 6-inch and Larger Service Installation.....	68
Detail 8 - 2-inch and Smaller Backflow Prevention Assembly Installation .....	69
Detail 9 - Standard 4-inch and Larger Fire Service Installation.....	70
Detail 10 - Fire Hydrant Installation .....	71
Detail 11 - Gate Valve Installation .....	72
Detail 12 - Valve Box Lid Markings.....	73
Detail 13 - Reserved	
Detail 14 - Standard Service Lateral Trench .....	75
Detail 15 - Standard Water Main Trench.....	76
Detail 16 - Sub-Standard Water Main Trench .....	77
Detail 17 - System Connection (Tie in).....	78
Detail 18 - Joint Restraint Installation .....	79
Detail 19 - Thrust Block Installation .....	80
Detail 20 - Traffic Bollard Installation.....	81
Detail 21 - Sample Station Installation .....	82
Detail 22 - Chlorination Tap Installation .....	83
Detail 23 - Blow Off Installation .....	84
Detail 24 - Air Valve Installation.....	85
Detail 25 - Below Grade Air Valve Installation.....	86

# Section 1 Technical Specifications

## 1 General Provisions

### 1.1 General

The Technical Specifications, Material Specifications and Standard Details herein are intended to cover the design, construction and testing of water distribution facilities owned by the City of Santa Cruz.

### 1.2 Scope

The purpose of Part I Standard Technical Specifications is to set forth the general criteria to be used in the design, construction and testing of water mains and appurtenances within SCWD service area, or are owned by the City. Any deviation from these standards must be supported in writing and approved by SCWD.

SCWD reserves the right to direct or deny use of installations that do not conform to the Standard Specifications set forth in these Technical Specifications, Material Specifications and Standard Details.

### 1.3 Definitions

Wherever the following words are used in these specifications, they shall have the following meanings.

City	The City of Santa Cruz
Contractor	The person, firm, company, corporation or authorized agent of such who enters into an agreement with another person, firm, company, corporation, or the City to build infrastructure which will become the property of the City
Contract Documents	All documents incorporated into the construction contract in whole or by reference which have been approved by the Engineer.
Director	The Director of the City of Santa Cruz Water Department
Engineer	The Deputy Director / Engineering Manager of the City of Santa Cruz Water Department, acting personally or through her authorized representatives.
Install	Provide complete in place; "furnish and install"
Maximum Density	The Density of backfill materials obtained by ASTM D1557.
Non Potable Line	Any pipe conveying sewage, treated sewage, storm drainage, recycled water, untreated water, any fuel including natural gas, or any hazardous fluid.
Relative Compaction	The percentage of the Maximum Density of backfill material as obtained by ASTM D1556 or ASTM D6938



## 1.4 Abbreviations

Wherever the following abbreviations appear in these specifications they shall refer to the following meanings.

AC	Asphalt Concrete	HORIZ	Horizontal
A-C	Asbestos Cement	IP	Iron Pipe
ACI	American Concrete Institute	IRR	Irrigation
ADU	Accessory Dwelling Unit	LTS	Length To Suit
ARV	Air Release Valve	MAX	Maximum
ASTM	American Society of Testing Materials	MG/L	Milligrams per Liter
AWWA	American Water Works Association	MIN	Minimum
CalTrans	California Department of Transportation	MIP	Male Iron Pipe
Bacti	bacteriological	MJ	Mechanical Joint
CI	Cast Iron	(N)	New
CIP	Cast Iron Pipe	No	Number
CL	Centerline, Class	NSF	National Sanitation Foundation International
CLSM	Controlled Low Strength Material	NTS	Not to Scale
COMP	Compression	OC	On Center
CONC	Concrete	OL	Open Left
Corp	Corporation	OR	Open Right
CTS	Copper Tube Size	OSHA	Occupational Safety and Health Administration
CY	Cubic yard	PL	Property Line
DCDA	Double Check Detector Assembly	PPM	Parts per Million
DEPT	Department	PRV	Pressure Reducing Valve
DIA, Ø	Diameter	PSF	Pounds per Square Foot
DI	Ductile Iron	PSI	Pounds per Square Inch
DIP	Ductile Iron Pipe	PVC	Polyvinyl Chloride
DOM	Domestic	RES	Residential
(E)	Existing	REQ'D	Required
EA	Each	RP	Reduced Pressure Principle Detector Assembly
EW	Each Way	RS	Riveted Steel
FIG	Figure	SCWD	The City of Santa Cruz Water Department
FIP	Female Iron Pipe	SF	Square Feet
FLG	Flange	SFD	Single Family Dwelling
FS	Fire Service	STD	Standard
FT	Feet	TYP	Typical
GA	Galvanized	USA	Underground Service Alert
GP	General Physical	VERT	Vertical
HDPE	High Density Polyethylene	WS	Welded Steel

## **1.5 Specification References**

All references to other specifications, standards, and details found in these specifications shall refer to the latest edition of that reference, unless noted otherwise.

Each section within Part I of these specifications implicitly refers to the applicable section(s) in Part II – Material Specifications.

The “City of Santa Cruz Department of Public Works Department of Parks and Recreation and Water Department - Standard Specifications” are supplementary to these specifications and are incorporated herein by reference. The City Standard Specifications are specific clauses setting forth the general requirements for contracting for work with the City of Santa Cruz.

In the event of a conflict between the City Standard Specifications and these specifications, the requirements set forth in these specifications shall prevail.

Wherever reference is made to the "State Standard Specifications" or to “Caltrans Specifications” reference shall be to the specifications entitled, "State of California, Department of Transportation, Standard Specifications,"

Wherever "SCWD Policy Statement 3” appears in this document, reference shall be made to the latest edition of the City of Santa Cruz Water Department Policy Statement No. 3 Backflow Prevention and Cross Connection Control.

## **1.6 Standard Details**

The SCWD Standard Details are to be followed in the installation of water mains and appurtenances. The Standard Details are attached and form Section 3 of these specifications.

## **1.7 Water System Plans**

Plans showing the size, type and location of infrastructure to be installed and other pertinent details shall be prepared for all water system improvement projects. All plans used for construction shall bear the seal and signature of a civil engineer registered in the State of California. Plans shall be approved by the Engineer prior to the start of actual construction.

If required by the Engineer, electronic copies of plans shall be submitted, conforming to the drafting standards provided by the Engineer. Plans and surveys shall be based on the North American Datum of 1983. Elevations shall be based on the North American Vertical Datum of 1988 or other as approved by the Engineer. The datums used shall be noted on the plans.

## **1.8 Development Plan Submittal Requirements**

Developments which require new water service, change of an existing service, relocation of existing water facilities, or which otherwise affect the water system shall be approved in advance by the Engineer.

Two sets of check prints shall be submitted for the Engineer to redline. Plans shall clearly show locations of all existing and proposed utilities and appurtenances, their material, class, diameter, and indicate depths at crossings and connection points. One set shall be returned to the developer with the Engineer’s comments.

Once plans have been approved by all applicable agencies, the developer shall submit five sets of final plans for SCWD use.

## **1.9 Submittals**

Prior to construction, and with sufficient time to verify compliance, the Contractor shall submit two copies of cut sheets and specifications for all materials proposed to be used in the construction of the project or which will become the property of the City. The Engineer shall approve or reject the submittals in writing based upon conformance with these specifications and the specifications referenced herein. No material shall be used for construction which has not been approved by the Engineer.

## **1.10 Permitting Requirements**

Prior to the commencement of work on any City owned facility or within the public right-of-way, the Contractor shall obtain all applicable permits from the City and any applicable permits from other regulatory agencies unless already obtained by City. A City permit may not be required provided the Contractor has entered into a formal Agreement with the City.

## **1.11 Licenses**

The Contractor performing the work shall possess state issued contractors license(s) as required by law and shall furnish satisfactory proof to the Engineer, upon request, that such licenses are in effect during the entire period of construction.

The Contractor performing the work shall be experienced in the type of work to be performed. No work shall commence until the Engineer has approved the Contractor and all subcontractors.

## **1.12 Rights-of-Way**

Where the location of the facility is not in public property, the developer or the City, at the option of the City, shall obtain a right-of-way and the title shall be vested in the City.

## **1.13 Inspection**

All work done for SCWD or to SCWD facilities shall be subject to rigid inspection. The Contractor shall provide safe access to all parts of the work as necessary for the Engineer to confirm compliance with these specifications and to record measurements. Work or materials that do not conform to the specifications may be rejected at any stage of the work. The Contractor shall remove and rebuild, at the Contractors expense, any part of the work that includes substandard materials or has been improperly executed.

## **1.14 Advance Notification and Scheduling**

The Contractor shall notify the Engineer not less than 48 hours prior to commencement of work. The Contractor shall keep the Engineer informed of the work schedule and alert the Engineer to any changes.

Whenever work done under these specifications is to be done on Saturday, Sunday or on holidays, the Contractor shall pay all costs to the City of such extra inspection. Prior approval by the Director must be obtained two working days in advance of such weekend or holiday work.

The Contractor should note that the City is closed for two weeks surrounding the winter holidays. Prior approval by the Director is required for work to take place during the closure.

## **1.15 Authority of Engineer**

On all questions concerning the acceptability of materials or equipment, the classification of material, the execution of the work and conflicting activities of Contractors performing related work, the decisions of the Engineer shall be final and binding on all parties.

## **1.16 Guarantee and Warranty Period**

The Contractor guarantees that any work performed by him/her under the agreement will be performed in the best manner; that any material furnished by him/her will be the best of its class; and, that both work and material will meet fully the requirements of these specifications.

The Contractor agrees that if, within a period of one year after final acceptance of the work done under the agreement, any part of said pipeline other structures or pavement constructed or installed by the Contractor or any subcontractor, fails to perform in accordance with these specifications, the Contractor will, without delay and with the least practical inconvenience and without further costs to the City, repair or replace defective or otherwise unsatisfactory parts of said facilities or pavement and install all additional materials if required, all to the satisfaction of the Engineer. Furthermore, the costs of any damage resulting from a failure of the aforementioned nature within the one year guarantee period shall be borne entirely by the Contractor.

Should the Contractor fail to act promptly in accordance with this requirement, or should the circumstances of the case require repairs or replacement to be made before the Contractor can be notified or can respond to notification, the City may, at its option, make the necessary repairs or replacements or perform the necessary work. The Contractor shall pay to the City the actual cost of such repairs plus standard overhead charges.

The Contractor shall be responsible for the full expense incidental to making good any and all of the above guarantees and agreements. The above guarantees and agreements are covenants and performance of which shall be binding upon the Contractor and his/her sureties.

## **1.17 Lines, Grades, and Alignments**

The Contractor shall establish all lines, grades and alignments indicated by the Contract Documents, subject to inspection, review and approval of the Engineer.

## **1.18 Separation Requirements**

Water facilities shall be located at such distances from possible sources of contamination to protect public health and safety. Water facilities shall be located at such distances from possibly damaging objects to ensure future serviceability. Unless stated otherwise, all measurements prescribed in this section shall be made to the nearest outside edge of the facilities. All distances are clearances.

### **1.18.1 Separation from Non Potable Lines and Hazardous Facilities**

New treated drinking water mains shall be constructed in compliance with The California Code of Regulations Title 22, Division 4, Chapter 16, Article 4, Section 64572.

If conditions require construction at clearances less than those prescribed by the above mentioned code, approval from the California Department of Public Health shall be obtained prior to construction.

Five feet clear horizontal distance shall be maintained between water service laterals and sanitary sewer laterals. Three feet clear distance shall be maintained between water service laterals and other utility lines.

Joint trenches with water lines and any other utility lines are prohibited.

No new non potable lines shall be constructed such that any of the above separation requirements are violated.

### **1.18.2 Separation From Trees**

No water facility shall be installed within 5 feet from the trunk of any tree. Wherever roots two inches in diameter or greater are encountered during the course of construction, such roots shall be protected in place and the facility re-aligned if necessary. Where circumstances do not allow for minor re-alignment, roots may only be cut with the approval of the City. All roots two inches in diameter or larger that are exposed by construction activities shall be protected from damage and drying out.

No tree shall be planted such that above separation requirements are violated.

## **2 Site Conditions**

### **2.1 Site Safety**

All work shall be planned and conducted with full attention to the safety of drivers, bicyclists, pedestrians, the public, and workers. The Contractor shall institute controls and procedures for the control and safety of all persons at or passing through the job site. Continuous maintenance of the work area is required. Traffic control and safety devices shall be maintained at all times day and night on all work that is not safe for the public until such time as it is made safe. The Contractor shall provide safe access to all parts of the work as necessary for inspection to confirm compliance with requirements and record measurements.

It shall be the Contractor's responsibility to provide for the convenience and safety of City employees, the Contractor's employees, the subcontractor's employees, and the general public in connection with the Contractor's operations. The Contractor shall conform to the rules and regulations pertaining to safety established by the California Division of Industrial Safety. Furnished equipment, materials, and services shall comply with all OSHA standards and regulations and all applicable laws and orders. The Contractor shall provide and maintain throughout the course of construction all temporary public walks, traffic control measures, warning signs, barricades, and other protective means and methods as may be necessary for the protection of the public from injury.

Safety precautions, means, methods, techniques, sequences, or procedures and programs related to safety are the sole responsibility of the Contractor. The Contractor shall also be responsible for compliance with the safety requirements by its subcontractors. The City will not supervise, control, or direct Contractor's safety precautions or programs, or inspect for safety conditions on work site, or of persons thereon, whether Contractor's employees or others. However, the City may notify the Contractor if made aware of a violation of the contract from a safety perspective and may halt work if an imminently dangerous situation is observed. After receipt of such notice, the Contractor shall promptly take corrective action. The City may report the violation to Cal-OSHA or other regulatory agency with jurisdiction and may issue a stop work order for failure to comply with safety requirements. The Contractor shall not make time lost due to any stop order related to safety the basis of a claim for an extension of time or for extra costs or damages.

Until the formal acceptance of the work by the City, the Contractor shall have the charge and care of the work and of the materials used therein, and shall bear the risk of injury, loss, or damage to any part thereof by the action of the elements or from any other cause, whether arising from the execution or from the non-execution of the work. The materials to be used in the work include both those furnished by the City and those furnished by the Contractor, including materials for which the Contractor has received partial payment. Contractor shall protect both finished and unfinished work from damage due to adverse weather at all times at no additional cost to the City. Work that becomes damaged due to the effects of adverse weather prior to City acceptance of the contract work shall be replaced or repaired to the Engineer's satisfaction at no additional cost to the City.

### **2.2 Traffic Control and Site Access**

The Contractor shall provide traffic control as a part of all operations affecting or with the potential to affect any means of transportation utilized by the public, including pedestrian, bicyclist and motorist traffic. The Contractor shall provide all traffic control signage and devices required by these specifications, and provide a sufficient number of competent personnel to operate said devices.

The Contractor shall coordinate traffic control and construction operations such that traffic is monitored and controlled at all times, yet inhibited as little as practicable, and public inconvenience is minimized.

The Contractor may re-route traveled ways, including motor vehicle lanes, bicycle lanes, and sidewalks, only in accordance with a traffic control plan approved prior to construction by the Engineer.

The Contractor shall not close traveled ways, including motor vehicle lanes, bicycle or pedestrian routes without the prior approval of the Director and five working days advance public notification by means of signage and/or advertisement to the satisfaction of the Engineer.

### **2.2.1 Control Devices**

The Contractor shall control motorist, bicyclist and pedestrian traffic by placing signs, barricades, and pavement delineators conforming to the California Manual on Uniform Traffic Control Devices and these specifications.

If construction activities block the bike lane, the Contractor shall post "Bike Lane Closed" and "Share the Road" caution signs to warn motorists to slow down and watch for bicyclists and pedestrians. Construction activities or construction signs that block the bikeway should have sufficient sight distance, including night time visibility, to allow cyclists time to merge safely into the car lane. Whenever possible, construction warning signs shall be placed out of bicycle, pedestrian, and vehicular paths of travel.

If it is necessary to close a sidewalk, the Contractor shall install signs which inform pedestrians that the sidewalk is closed and direct pedestrians to a safe alternate route. Barriers in walkways shall include a portion low enough and solid enough to be easily discernible by a cane, guide dog or child. If construction activities or construction signs block pedestrian routes, the Contractor shall establish safe, well-signed detours for pedestrians, which are accessible for wheel chairs, strollers, carts, etc. Detours shall have sufficient warning to allow wheelchairs time to exit the walkway at a prior curb ramp.

If any component in the traffic control system is damaged, vandalized, stolen, displaced or ceases to operate or function as intended, from any cause during the progress of the work, the Contractor shall immediately repair said component to its original condition or replace said component and shall restore the component to its original location.

### **2.2.2 Pedestrian Bridges**

Pedestrian bridges of construction approved by the Engineer, shall be installed over the trench at all crosswalks and intersections, and at other points where, in the opinion of the Engineer, traffic conditions make it necessary. Bridges shall not be less than 4 feet in width and shall be provided with hand rails. Transitions between pavement and bridge surface shall be tapered at the edges for pedestrian and wheelchair safety.

### **2.2.3 Site Access During Working Hours**

Vehicular and pedestrian access to all businesses, residences, and all property adjacent to the site shall be maintained at all times or provided as needed. If this requirement can be demonstrated to be the cause of extreme construction hardship, alternative coordination and provisions may be implemented with the approval of the Engineer. In general, work shall stop periodically and excavations shall be plated to allow access. Temporary approaches to, and crossings of, street intersections shall be provided and kept in good condition. The Contractor shall make way for emergency vehicles through the work area and to adjoining properties at all times as needed regardless of temporary closure or other traffic controls.

### **2.2.4 Site Access During Non-working Hours**

The Contractor shall keep all traveled ways open to the public during nights and weekends throughout the construction period, unless otherwise approved by the Director and five working days advance public notification is provided by means of signage and/or advertisement to the satisfaction of the Engineer.

All holes, trenches, etc., in publicly traveled areas shall either be covered with steel trench plates, or backfilled and paved with temporary pavement or permanent pavement in accordance with the applicable sections of these specifications. Steel plates shall be maintained movement-free at all times with stakes, shims and welds. Plates shall have temporary asphalt compacted around the edges so that transitions are smooth. Temporary asphalt shall be regularly maintained to provide a surface free of potholes and resistant to the intrusion of water into the subgrade.

## **2.3 Site Cleanliness**

The Contractor shall keep the construction site in a neat and sanitary condition at all times. All trash and excess excavated material shall be removed from the site as soon as possible and immediately at the request of the Engineer. On or before completion of the work, the Contractor shall remove all temporary structures and leave all areas in a condition satisfactory to the Engineer.

All traveled ways including streets, bikeways, and walkways, shall be swept by power or hand broom at the end of each workday and as needed while open for use by the public. Debris shall be cleared by the end of each workday. All areas accessible to the public shall be kept clean and free of debris at all times.

## **2.4 Site Restoration**

The Contractor shall replace in kind or otherwise restore all property damaged or affected by the construction, including street surfaces, sidewalks, striping, markings, signage, curbs, gutters, pipes, conduit, gas, water and other utilities, sewers, monuments, stakes, trees, shrubs, landscaping, and other public or private property to a condition equal to or better than the condition prior to construction. Restoration shall follow construction as the work progresses and shall be completed as soon as possible. Construction signs shall be promptly removed when construction pauses or ends. Final restoration that cannot be performed promptly due to adverse weather conditions may, upon written request that includes a proposed procedure and time schedule, be performed as approved by the Engineer.

## **2.5 Dust Control**

During the performance of all work, the Contractor shall assume all responsibility for dust control and shall furnish all labor, equipment, material, and means necessary to carry out proper measures wherever and whenever dust control is necessary to prevent the operations, stockpiles, and staging areas from producing nuisance dust to persons or property.

The City may notify the Contractor if made aware of nuisance dust. After receipt of such notice, the Contractor shall promptly take corrective action. The City may issue a stop work order for failure to comply with dust control requirements. If dust problems should continue, the City may halt construction until Contractor implements such means and methods as to abate all fugitive dust.

No compensation of any kind shall be provided to the Contractor by the City for construction delays due to stop orders related to dust. The Contractor shall not base any damage claims or time extension requests upon any stop order related to dust.

Any claims against the City resulting from fugitive dust shall be borne by the Contractor. Any fines levied to the City as a result of dust caused by the Contractor shall be borne by the Contractor. Such costs may be deducted by the City from any monies due or that will become due to the Contractor under the Contract.

## **2.6 Water Pollution Control**

The Contractor shall keep on site and ready at all times during construction all equipment and materials needed to be implemented to ensure the protection of all surface water bodies and sewer and storm drain systems from runoff which may be contaminated by sediment, sawcut slurry or other pollution in the event



of an emergency water facility breakage, trench dewatering activity, or wet weather event that may erode stockpiles or exposed soil areas. The Contractor shall prevent the transport of sediment to storm drains or receiving waters during open channel discharges containing sediment or having the potential to entrain sediments.

The Contractor shall ensure that no water is discharged containing concentrations of pollutants in excess of applicable water quality objectives, or containing substances in concentrations toxic to human, animal, plant, or aquatic life, or containing contaminated ground water. The Contractor shall ensure that no water containing measurable chlorine residual greater than or equal to 0.02 mg/L residual is discharged to any storm drainage system or surface water body.

The Contractor shall not increase the turbidity of receiving waters beyond the following limits: Where natural turbidity is between 0 and 50 Nephelometric Turbidity Units (NTU), increases shall not exceed 20 percent. Where natural turbidity is between 50 and 100 NTU, increases shall not exceed 10 NTU. Where natural turbidity is greater than 100 NTU, increases shall not exceed 10 percent.

Water from trench dewatering operations may be pumped into the sanitary sewer only with prior approval by the Owner of the facility. Such discharge shall not be allowed to cause overflow at any manhole, either upstream or downstream. The Contractor shall be responsible for monitoring of the sewer system during any approved discharge.

The Contractor shall immediately notify the City whenever a discharge of sediment or other pollutants occurs. The Contractor shall either document the discharge characteristics to the satisfaction of the Engineer or pay the City for the costs of monitoring. Upon discovery of an illicit discharge, the Contractor shall promptly take corrective action. The City may issue a stop work order for failure to comply with pollution control requirements. If the discharge should continue, the City may halt construction until Contractor implements such pollution controls.

No compensation of any kind shall be provided to the Contractor by the City for construction delays due to stop orders related to pollution. The Contractor shall not base any damage claims or time extension requests upon any stop order related to pollution caused by the Contractor.

Should the Contractor fail to provide water pollution controls as needed or be negligent in causing the water pollution, the City or other agency may implement emergency pollution control measures. Costs for such mobilization, implementation, materials, reporting, and clean-up shall be borne by the Contractor if responsible for the pollution. Such costs may be deducted by the City from any monies due or to become due to the Contractor under the Contract.

Any claims against the City resulting from pollution shall be borne solely by the Contractor. Any fines levied to the City as a result of pollution caused by the Contractor shall be borne by the Contractor. Such costs may be deducted by the City from any monies due or that will become due to the Contractor under the Contract.

## **2.7 Discovery of Archaeological Resources**

Construction activities may lead to the inadvertent discovery of archaeological resources within the project area. These resources may include but are not limited to historical objects, bottles, ceramics, shells, beads, flaked or ground stone tools, bones, human remains, village sites, remains of buildings, or old dump sites unearthed by Contractors in the course of their work activities.

Should the Contractor or subcontractor discover a suspected archaeological resource, the Contractor shall immediately stop excavation in the vicinity of the find, and notify the City. The portion of the excavation in which the discovery was made shall be secured until the discovery can be evaluated. The Contractor shall protect with steel plates and provide access to the discovery site as needed. Work shall not resume in that location until the Contractor receives authorization from the City.

Archaeologists, monitors, and Native American Observers may be retained by the City and may be present during ground disturbing activities associated with the project that occur within the areas determined by the City to be archaeologically sensitive and as needed. Native American observers may be on site during ground disturbing activities associated with the project that occur within probable burial or sacred sites. The contractor shall extend the same access and safety considerations to such archaeology related monitors as is required to be provided to the City inspector. The Contractor must stop excavation at the request of such monitor or City Inspector and shall not make time lost due to any stop request related to the evaluation of archaeological resources the basis of a claim for an extension of time or for extra costs or damages unless such delay exceeds 15 minutes in any one incident or more than 25 minutes in any single day's work.

## **3 Excavation**

### **3.1 General**

The Contractor shall perform all excavation indicated by the Contract Documents or the Engineer. The excavation shall include the removal and disposal of all materials, of whatever nature encountered, including groundwater, abandoned utilities and sub-surface obstructions.

### **3.2 Protection of Existing Facilities**

All construction activities in the vicinity of other utility lines, conduits, services, and other structures, or appurtenances thereto, shall be executed in such manner as not to interfere with their safe operation. Proper precautions shall be taken to prevent damage to other utilities.

The Contractor shall maintain access at all times to manholes, valves, poles, hydrants, panels and other utility controls to utility operators and emergency workers. No material or other obstruction shall be placed within 15 feet of any fire hydrant that is in service. If the Contractor can demonstrate that this requirement is the source of extreme construction hardship, special alternative provisions may be implemented with the approval of the City and the service owner/operator. The Contractor shall not interrupt any service without a minimum of three working days notice to the City of Santa Cruz Water Department and the utility owner, and 48 hours notice to any utility customers affected.

#### **3.2.1 Proper Precautions to Avoid Damage to Facilities**

The Contractor shall become familiar with all readily available sources of information regarding existing utilities. The Contractor is responsible for verifying the location, size and extents of all utilities shown on plans, marked on site, or otherwise inferred from surface features in order to reduce the possibility of damage during the course of construction.

The Contractor shall comply with Underground Service Alert procedures (USA). The Contractor shall excavate by hand digging when excavating within 24 inches of an existing facility. Markings depicting sub-surface facilities may be up to 24 inches horizontal from outside edge of actual location of facility and still be considered properly marked. Depth information will not necessarily be provided. It is the Contractor's responsibility to carefully locate the utility at whatever depth it exists. The Contractor will not be expected to hand dig through pavement. If a marked facility is not encountered within 24 inches of USA marks, the Contractor should immediately call USA and request re-mark. If the Contractor proceeds with non-hand dig excavation methods prior to re-mark, then any damage inflicted upon the facility, even if miss-marked, is the responsibility of the contractor.

Sanitary sewer laterals are typically owned by private individuals and will not necessarily be marked or otherwise located. Cleanouts may not exist or be available to help locate sewer laterals. Non-pressurized sanitary sewer and storm drain facilities in general are not required to be located by the regional notification center regulations. Contractor is responsible for all repairs to damaged non-pressurized sanitary sewer facilities, regardless of markings, if any.

Abandoned facilities are not required to be located per the regional notification center regulations. If an abandon facility is found, the Contractor should contact the suspected owner or operator of the facility in question to confirm abandonment and safety of the abandoned facility prior to removal. The Contractor shall not make adjustments to the locations or alignments of new facilities without the approval of the Engineer. It shall be the decision of the Engineer whether to re-align the new construction or remove the abandoned facility.

The Contractor shall verify the exact locations of underground facilities by "potholing" sufficiently in advance of sawcutting and excavation operations so that locations and alignments can be confirmed

or re-evaluated without delay. If the Contractor is forced to reconstruct or reinstall materials in order to make minor alterations to alignment, grade, or location due to existing utilities, such minor alterations shall be made at no expense to the City.

### **3.2.2 Repairs to Damaged Facilities**

Should the Contractor, disturb, disconnect, or damage any utility facility, the Contractor shall immediately notify the owner or operator of the facility. The owner of the damaged utility shall have the option to have the facility repaired by the Contractor, by a third party contractor of the utility's choice, or to perform the repair itself. If the Contractor is to repair the damaged facility, the repair shall be made within the time frame stipulated by the owner of the facility.

In the case where the facility has been damaged as a result of the Contractor's failure to comply with the notification requirements of the regional notification center (Underground Service Alert or USA), or the requirements of these specifications, and the owner or operator of the facility has complied with the regional notification center requirements, all costs for the repairs to the facility shall be borne by the Contractor. Any claims made against the City by the owner or operator of the facility shall be paid by the Contractor. Such costs may be deducted by the City from any monies due or that will become due to the Contractor under the Contract. No compensation of any kind shall be provided to the Contractor by the City for construction delays due to repairs to damaged facilities. The Contractor shall not base any damage claims or time extension requests upon any delay related to repairs to facilities damaged by the Contractor.

In the case where the owner or operator of the facility has failed to comply with the regional notification center system requirements, that owner or operator shall forfeit any claim for damages to the facility arising from an excavator who has complied with the requirements and to the extent damages were proximately caused by the owner or operator's failure to comply. Claims for damages or delays to construction caused by repairs to damaged facilities shall be made directly with the owner/operator of the facility, and not through SCWD, unless SCWD is the owner/operator.

### **3.3 Saw Cutting and Pavement Removal**

Where excavation is located within paved areas, the pavement shall be neatly saw cut and removed. Saw cuts shall be made beyond the limits of excavation, such that an appropriate "tee section" may be constructed conforming to Details 14 or 15, or the requirements of the appropriate public works agency. Saw cutting for trenches outside of the city limits shall conform to the County of Santa Cruz Public Works Figures EP-1, EP-2, and EP-3.

If the saw cut limits are within two feet of edge of pavement, gutter lip or face of curb, the pavement shall be removed completely to that edge.

If saw cut edges become damaged during construction, the Contractor shall make a new saw cut so that edges are neat, vertical and follow straight lines, at no expense to the City.

Where excavation is located within concrete sidewalk, the Contractor shall neatly saw cut the sidewalk only on existing scores. The saw cut limits shall be approved by the Engineer.

### **3.4 Trench Excavation**

Excavation of the trench shall follow lines parallel to and equidistant from the pipe centerline. Trenches excavated within city limits shall conform to Details 14 or 15 and these specifications. This includes all pipelines, services and special location trenches that are excavated in conjunction with the project. Trenches outside of the city limits shall conform to the County of Santa Cruz Public Works Trench Backfill Standards, Figures EP-1, EP-2, and EP-3.

Excavations shall be made to depths and widths required to accommodate construction of the pipeline and structures. In general, excavation shall be made to provide the standard depth of cover to finish grade of 36 inches over the top of the pipe. Excavation shall be made to additional depth if indicated by the Contract Documents or required by the Engineer. Prior approval of the Engineer is required if pipe is to be installed with sub-standard cover.

### **3.5 Trench Base Preparation**

The trench bottom should be constructed to provide a firm, stable and uniform support for the full length of the pipe. Bell holes should be excavated at each joint to permit proper joint assembly and pipe support. Any part of the trench bottom excavated below grade should be backfilled to grade and should be compacted as required to provide firm pipe support. Where, in the opinion of the Engineer, material encountered at the bottom of the trench is found to be unsatisfactory for properly supporting the pipe, additional trench depth shall be excavated, and refilled with material approved by the Engineer. Where the water main is installed in fill areas, the bottom of the trench shall have been compacted to a minimum of 95% relative compaction before the pipe is installed.

### **3.6 Bell Holes**

Bell holes shall be excavated in the bottom of the trench at pipe joint locations of such size that the process of making joints and inspection can be carried on satisfactorily and so that the pipe barrel will bear evenly on the bearing base.

### **3.7 Blasting**

No blasting will be permitted without the approval of the Engineer. When blasting is permitted, it shall be done only by skilled operators and under the direction of a competent foreman.

Blasting will be permitted only when proper precautions are taken for the protection of persons, the work and existing structures. Any damage done to persons, private property, the work, or existing structures shall be the responsibility of the Contractor. Storage, handling and the use of explosives shall be in accordance with the State of California (Construction Safety Orders of the Division of Industrial Safety).

Blasting shall be done with explosives of such power and in such quantities and positions as not to make the excavation unduly large, not to shatter the rock upon or against which embankments or concrete will be placed, not to shatter the faces of cuts which are to remain open or not to injure masonry or other structures already built. Whenever, in the opinion of the Engineer, further blasting is liable to injure such rock or masonry, the Contractor shall cease blasting and continue to excavate the rock by other approved methods.

Excessive blasting or "overshooting" will not be permitted and any material outside the authorized cross-section which may be shattered or loosened by blasting shall be removed and replaced with concrete or earth, as specified by the Engineer, at the Contractor's expense. The Engineer shall have authority to require the Contractor to discontinue any method of blasting which leads to overshooting or is dangerous to the public or destructive to property or to natural features.

Permits for blasting shall be obtained and paid for by the Contractor.

### **3.8 Bracing and Shoring**

Excavations shall be adequately shored and braced so that the earth will not slide or settle, and so that all existing improvements and facilities will be fully protected from damage. All bracing and shoring shall comply with the State of California Construction Safety Orders of the Division of Industrial Safety, and OSHA excavation standards 29 CFR 1926, Subpart P, Trenching and Excavations. Any damage resulting from lack of or inadequate shoring and bracing shall be the responsibility of the Contractor, and

all costs for repairs shall be borne by the Contractor. Any claims made against the City by the owner or operator of a damaged facility shall be borne by the Contractor. Such costs may be deducted by the City from any monies due or that will become due to the Contractor under the Contract. No compensation of any kind shall be provided to the Contractor by the City for construction delays due to repairs to damaged facilities. The Contractor shall not base any damage claims or time extension requests upon any delay related to repairs to facilities damaged by the Contractor. The Contractor shall bear all other expenses resulting from such damage.

### **3.9 Disposal of Excavated Materials**

All excavation spoils and demolished facilities shall be removed from the job site promptly and disposed of at a legal disposal site. No spoils or construction debris may be stockpiled within the Right-Of-Way overnight. Temporary stockpiles of materials shall not obstruct vehicular, pedestrian, or bicyclist traffic. Gutters and catch basins shall be maintained and protected from contamination by construction materials and debris at all times.

When working within the City limits, the Contractor must use the City's Sanitation Services for drop-boxes which are to be left at the site or on the street. The Contractor may provide other hauling services with a truck, or with a roll-off box or container that is left attached to the vehicle while at the site.

The Contractor is responsible for worker health and safety and instructing workers on the recognition and reporting of materials that may be hazardous. The Contractor shall provide and pay for testing and analysis by an approved laboratory of suspected impacted soils and groundwater and shall submit results to the City. Any materials to be removed in the course of work that are found to contain hazardous substances as defined by California Health and Safety Code Section 25117 shall not be transported without prior notification and an approved plan of action. Contractor shall minimize delays by continuing performance of the work in areas not affected by hazardous materials operations.

The Contractor shall be responsible for the proper removal and disposal of asbestos-containing materials when necessary for the installation of new facilities or as called for in the course of work. Contractor shall comply with all current federal, state, and local laws, standards, and regulatory agency requirements concerning the handling of asbestos containing materials. Removal and disposal of existing asbestos materials shall be performed using means and methods as recommended by the American Water Works Association, as allowed by OSHA, and by employees who have been properly trained as required by OSHA. Contractor shall submit a copy of all relevant CAL/OSHA documentation, and documented worker training to City prior to handling any asbestos containing materials. Asbestos disturbance and or removal activities shall be conducted by properly trained, accredited, and licensed personnel using proper protective equipment. Such activity must be performed within a posted regulated area intended to keep unauthorized people out of the asbestos work area. Transite pipe shall be cut only with a snap type cutter and never with an abrasive saw. Field cut transite pipe ends shall not be re-beveled. Asbestos-containing materials must be kept wet and as intact as possible. Such materials must be promptly sealed leak tight in a six mil thick poly bag with labeling that meets OSHA requirements and hauled to a legal disposal facility that accepts asbestos-containing construction debris along with the appropriate waste manifest. The Contractor shall submit a copy of the waste manifest to City in order to document proper disposal

## **4 Installation of DI and PVC Pipe**

### **4.1 General**

Ductile Iron water mains and water service laterals shall be installed in accordance with AWWA Standard C600, and these specifications. Polyvinyl chloride water mains and water service laterals shall be installed in accordance with AWWA Standard C605, AWWA Manual M23, and these specifications.

### **4.2 Handling of Pipe and Accessories**

Proper implements, tools, and facilities satisfactory to the Engineer shall be provided and used by the Contractor for the safe prosecution of the work. All pipe, fittings, and valves shall be carefully lowered into the trench, piece by piece, by means of a crane, ropes or other suitable equipment, in such manner as to prevent damage to water main material, protective coating and lining. Under no circumstances shall water main materials be dropped into the trench.

### **4.3 Laying Pipe**

#### **4.3.1 Cleanliness**

Every precaution shall be taken to prevent foreign material from entering the pipe. If the pipe-laying crew cannot put the pipe into the trench and in place without getting earth or water into it, the Engineer may require that before lowering the pipe into the trench, a heavy, tightly woven canvas bag of suitable size shall be placed over each end and left there until the connection is to be made to the adjacent pipe. No debris, tools, clothing or other material shall be placed in the pipe. The contractor shall visually inspect each piece of pipe to verify cleanliness.

At times when pipe-laying is not in progress, the open ends of pipe shall be closed by a water-tight plug or other means approved by the Engineer. If water is in the trench, the seal shall remain in place until the trench is pumped completely dry.

If trench water enters the pipe during construction, or if in the opinion of the Engineer, the pipe has become contaminated, the Special Testing Procedures shall be followed in accordance with the pertinent sections of these specifications.

#### **4.3.2 Unsuitable Conditions for Laying Pipe**

No pipe shall be laid in water or when, in the opinion of the Engineer, trench conditions are unsuitable. Every precaution shall be taken against floating of the pipe, either in existing lines or in the new lines, due to water entering the trench. In case of such floating, the Contractor shall replace or re-lay the pipe at and make good any injury or damage which may have resulted at no expense to the City. All remedial work shall be executed in accordance with the pertinent sections of these specifications.

#### **4.3.3 Direction of Laying**

Pipe shall be laid with the bell ends facing in the direction of laying, unless directed otherwise by the Engineer.

#### **4.3.4 Polyethylene Encasement**

When indicated by the Contract Documents, or directed by the Engineer, the Contractor shall install DI pipe and fittings with polyethylene encasement in accordance with AWWA Standard C105, Section

4.4, Method A. Care shall be taken to prevent soil and foreign material from entering the space between the pipe and wrap.

## **4.4 Joints for Pipe and Fittings**

### **4.4.1 Cutting Pipe**

The cutting of pipe for inserting valves, fittings or closure pieces shall be done in a neat and workmanlike manner without damage to the pipe or cement-mortar lining and so as to leave a smooth end at right angles to the axis of the pipe. The flame cutting of pipe by means of an oxyacetylene torch is prohibited.

### **4.4.2 Cleaning Joint Surfaces**

All lumps, blisters and excess coal tar coating shall be removed from the ends of DI pipe. The outside of the spigot and the inside of the bell of DI pipe shall be wire brushed and wiped clean and dry and free from oil and grease before the joint connection is made.

The outside of the spigot and the inside of the bell of PVC pipe shall be wiped clean and dry and free from oil and grease before the joint is made.

### **4.4.3 Permissible Deflection at Joints**

Wherever it is necessary to deflect pipe from a straight line, either in the vertical or horizontal plane, to avoid obstruction or to plumb stems, or where long-radius curves are permitted, the deflection shall not exceed the manufacturer's recommendation. Bends shall be used whenever individual deflections exceed those specified by the manufacturer.

### **4.4.4 Joint Types**

Joints between lengths of DI pipe shall be push-on rubber ring, or mechanical joint. Joints between lengths of PVC pipe shall be push-on rubber ring. Other joint types shall be approved by the Engineer.

All pipe joints shall be installed in accordance with the pipe manufacturer's instructions.

The pipe shall be marked a known distance from the end of the spigot, so that spigot embedment in the joint may be verified. Pipe spigots shall be evenly beveled and thoroughly de-burred. Pipe joint surfaces shall be wiped clean and gasket lubricant applied immediately prior to joint assembly to prevent dirt from becoming lodged in the gasket.

All uncoated areas of fittings and joint related hardware shall be completely covered in bitumastic coating by either brush or spray application to protect against corrosion.

### **4.4.5 Restrained Joints**

Pipe joints shall be restrained at all fittings, valves, and where required by the Engineer. In addition to the fitting joints themselves, a length of pipe, as measured along the pipe from the fitting, shall be restrained. The restrained length shall be determined from Detail 18, or specified by the Engineer.

All joint restraint hardware shall be installed in accordance with the manufacturer's instructions. Bolts shall be tightened to the manufacturer-recommended torque. A torque wrench shall be used to tighten pipe-gripping joint restraints if the factory-provided break-away bolt heads are missing.



All uncoated joint restraint related hardware shall be completely covered in bitumastic coating by either brush or spray application to protect against corrosion.

In addition to restraining joints as described above, the Contractor shall install thrust blocks or reverse anchors in accordance with the pertinent sections of these specifications and Detail 19.

#### **4.5 Miscellaneous**

The Contractor shall install test stations, insulating fittings, joint bonds and other cathodic protection facilities as indicated by the Contract documents, or the Engineer.

## **5 Installation of Steel Pipe**

### **5.1 General**

Installation of steel pipe shall be installed per AWWA Standard C604 and AWWA Manual M11.

### **5.2 Handling of Pipe**

Whenever a section of lined and coated or wrapped steel pipe is to be lifted or moved, it shall be handled in such a manner as not to distort the pipe excessively and/or damage the lining, coating, or wrapping in any way.

Belt slings shall be used whenever coated pipe is to be lifted. The belt shall be so constructed that no metal bears against the pipe coating.

### **5.3 Laying Pipe**

The pipe shall be accurately laid to grades and alignments indicated by the Contract Documents. It is the intent of this specification that the pipe be installed as prefabricated in the shop by the manufacturer. If a discrepancy is discovered during installation between field conditions and the Contract Documents, the first attempt at conformity shall be to re-grade the area in question before the pipe is altered in the field to meet ground conditions. In any case, the decision of the Engineer shall be final.

Pipe sections shall be thoroughly cleaned just prior to being placed in position. Pipe installed in the trench shall have uniform support along the base, except at bell holes provided for field joints or other structures.

Pipe shall be laid and joined in accordance with instructions of the pipe manufacturer. Joint deflections shall not exceed the maximum recommended by the manufacturer.

If trench water enters the pipe during construction, or if in the opinion of the Engineer, the pipe has become excessively contaminated, The Special Testing Procedures described in these specifications shall be followed.

### **5.4 Field Joints**

Field joints may be lap welded, flanged, flexible coupled or of the rubber gasket bell and spigot type. Flanged joints shall be fitted with ring gaskets.

The jointing operation for bell and spigot pipe shall provide for the use of a feeler gauge to check the position of the rubber gasket for proper seating. If pipe is specified as cement mortar lined, all joints shall be finished inside with cement mortar after final placement.

After joints in wrapped or coated pipe have been inspected, exterior wrapping or coating shall be applied to the joints so as to produce a protective covering equal to that of the manufactured pipe.

### **5.5 Field Alterations and System Connections**

Whenever the pipe is cut for the purpose of making alterations or closures, the coating shall be cleaned back from the line of cut approximately 3 inches, and the pipe shell accurately cut.

All field-fabricated elbows shall be in accordance with AWWA Standard C208, Table 2.

## **5.6 Welding**

Welding of steel pipe shall conform to the Standard Specification of the American Water Works Association for Field Welding of Steel Water Pipe Joints and designated as AWWA Standard C206, and shall be done by a certified welder.

## **5.7 Miscellaneous**

The Contractor shall install test stations, insulating fittings, joint bonds and other cathodic protection facilities as indicated by the Contract Documents.

## **6 Installation of Appurtenances**

### **6.1 Hot Tap Connections**

In the locations indicated by the Contract Documents or the Engineer, the Contractor shall install a hot tap connection in accordance with these specifications, Detail 1, and AWWA C600 or C605. No hot tap connections shall be made without the presence of the Engineer. The Contractor shall schedule inspection with SCWD a minimum of two working days in advance of making any hot tap connection.

#### **6.1.1 Tap Location**

The Contractor shall expose the main for 24 inches on either side of the proposed tap location to confirm that no other taps, bells, or other fittings exist near the new tap. No taps shall be made within 18 inches of another tap, nor 24 inches from any fitting, bell, or other joint. Multiple taps in the same stick of pipe shall be staggered around the circumference of the pipe.

#### **6.1.2 Tap Installation**

The Contractor shall clean the main and install the appropriate tapping saddle or sleeve. Direct taps are prohibited. The bit used to drill into the main shall be a hole-saw or shell bit unless approved otherwise by the Engineer. For services smaller than 4 inches, the diameter of the bit shall not be smaller than one eighth of an inch less than the size of the service. For services 4 inches and larger, the diameter of the bit shall not be less than one quarter of an inch less than the size of the service. The bit shall be equipped with a coupon-retention mechanism, such as a barbed pilot bit.

#### **6.1.3 Use of Purge Valve**

During the tapping operation, the Contractor shall maintain positive flow of water out of the main, such that cuttings are continuously flushed out. This may be achieved by opening the purge valve on the tapping equipment or tapping saddle or sleeve. If the tapping equipment does not have an integral purge valve, the Contractor shall install a temporary tee between the corporation stop and the tapping machine, and attach the purge valve to the tee.

#### **6.1.4 Polyethylene Encasement**

When a hot tap connection which utilizes brass and copper, is made to an iron or steel main, the brass tapping saddle shall be completely covered in bitumastic coating by either brush or spray application. The main, saddle and service line shall be encased in polyethylene wrap for a minimum distance of 3 feet from the hot tap connection.

When a hot tap connection is made to a main which is encased in polyethylene, the polyethylene shall be neatly cut back out of the way of tapping operations, and protected from damage. In accordance with AWWA C105, the finished hot tap connection, associated hardware and service line shall be encased in polyethylene wrap for a minimum of 3 feet along the service lateral from the encased pipe.

### **6.2 Installation of Valves**

The Contractor shall install valves at the locations indicated by the Contract Documents or where directed by the Engineer. Valves shall not be located in concrete sidewalks, aprons or gutters, unless approved by the Engineer. On mains smaller than 12 inches in diameter, the spacing between valves shall not exceed 1,320 feet. Four valves shall be installed at each cross. At least one valve shall be installed at each tee on the leg branching from the tee. Valves shall be installed directly on the cross or tee, unless directed otherwise by the Engineer.

Installation of valves shall conform to Detail 11 and these specifications. For all valve installations where the top of valve nut is more than four feet below the ground surface, a valve nut extension shall be installed so that the operating nut is within 12 inches of the ground surface. Valve nut extension stems shall have a rust-inhibitive coating and be equipped with a circular spacer to ensure that the stem extension stays centered within the valve box.

Joints between valves and pipe or other fittings shall be restrained in accordance with the pertinent sections of these specifications for the applicable pipe type. Joints in pipe adjacent to valves shall be restrained in accordance with the pertinent sections of these specifications and Detail 18.

Uncoated joint hardware, and areas on the valve body where coating has been damaged shall be completely covered in bitumastic coating by brush or spray on application to prevent corrosion.

The Contractor shall note that only SCWD Personnel are authorized to operate valves on the existing system. The Contractor may operate valves on new construction that has not been connected to the existing SCWD water system.

### **6.2.1 Valve Box Installation**

A valve box and lid shall be installed over operating nuts per Detail 11. If valve boxes are exposed above the ground surface, they shall be protected from damage until completion and acceptance of the contract work.

Valves boxes shall be installed flush with finished grade and centered on the valve nut, such that the centerline of the riser is aligned with the axis of the operating nut. Valve boxes and risers which have shifted during backfill operations and are no longer aligned in this manner shall be re-excavated and realigned to the satisfaction of the Engineer.

Valve box lids shall be marked in accordance with Detail 12.

Valve boxes and lids shall be inspected by the contractor prior to installation to ensure that the lid is silent when driven over by vehicles. Noisy gate valve boxes and/or lids shall be removed and replaced at no expense to the City, or shall be remedied in a manner acceptable to the Engineer.

### **6.2.2 Valve Box Adjustment**

Valve box rims shall be adjusted to be flush with the finished grade whenever paving is overlain or existing grades are changed. Adjustment shall be made by removing paving, concrete collar or redwood blocks, and affected backfill. Valve boxes with existing concrete collars shall be replaced with a new valve box. A new concrete collar shall be poured around the box per Detail 11. Pavement or landscaping surrounding valve box shall be replaced in-kind. Use of grade rings is prohibited.

Damaged lids shall be replaced. Valve box lids shall be marked in accordance with Detail 12. Replacement lids shall be inspected by the contractor to ensure that the lid is silent when driven over by vehicles. Noisy gate valve boxes and/or lids shall be removed and replaced at no expense to the City, or shall be remedied in a manner acceptable to the Engineer.

## **6.3 Installation of Blow-Offs**

Where indicated by the Contract Documents or designated by the Engineer, the Contractor shall install either a temporary or permanent blow-off. A permanent blow-off is defined as one that will be left in place upon completion of the work. Permanent blow offs shall conform to Detail 23 and these specifications. Temporary blow-offs shall be removed by the Contractor after testing has been completed and approved by the Engineer. The Contractor shall execute all work related to the installation and removal of blow-offs in accordance with the pertinent sections of these specifications. Unless otherwise specified by the

Engineer, the size of blow-offs shall be 2 inches. Blow-offs shall be installed on mains at low points, dead-ends and disinfection locations.

## **6.4 Air Valve Installation**

The Contractor shall install an air valve in accordance with these specifications and Detail 24 at locations indicated by the Contract Documents or where required by the Engineer. Air valves are required at each high point in all transmission water mains 12 inches in diameter and larger. Air release valves shall be located so that the vent opening is above the 100-year flood level or the highest recorded water level, whichever is higher.

If indicated by the Contract Documents or the Engineer, the Air valve shall be installed in a below grade configuration per Detail 25. Air valves may be installed in below grade configuration only with prior approval of the Engineer.

In locations where vandalism of the air valve is a concern, the Engineer may require that the Contractor install a locking steel enclosure. The enclosure shall be installed upon a reinforced concrete pad and shall be painted with "hunter green" enamel

## **6.5 Fire Hydrants**

Fire hydrants are allowed for public fire protection purposes only. Private hydrants may be located on private property but shall be connected to a standard fire service with an approved backflow prevention device. Adequate water main size and point of connection shall be verified prior to installation. Water main replacement or extension may be required to provide adequate pressure and flows. The Contractor shall provide 48-hours notice to SCWD to schedule inspections prior to construction. Out of service hydrants shall be bagged with a canvas or orange bag. The Engineer shall notify the local fire agency when hydrants are turned on or off.

### **6.5.1 Fire Hydrant Location Requirements**

Fire hydrant locations shall be approved by the Engineer and the local fire department prior to installation. The installer/developer shall notify the owners of all properties within 250 feet of the proposed hydrant location in writing a minimum of five working days before the hydrant is installed.

Fire hydrants shall connect only to water mains 6 inches and larger in diameter. If the water main is less than 6 inches in diameter, the main shall be upsized.

The standard location for fire hydrants is in the sidewalk with the center of hydrant set 9 inches back from the back of curb. Clear sidewalk width around fire hydrant, including protrusions, shall not be less than 3 feet. Where the sidewalk is less than 6 feet wide, the hydrant location shall be approved by the applicable public works agency, in addition to the Engineer and fire department.

No fire hydrant shall be located within 10 feet of a driveway approach. No fire hydrant shall be located within 3 feet of private property lines.

No fire hydrant shall be located within 3 feet of walls, poles, or any other vertical obstructions. No fire hydrant shall be located within 4 feet of a mature shrub. Consideration shall be given to proximity of young shrubs. No fire hydrant shall be located within the drip line of existing mature trees. Consideration shall be given to the proximity of young trees.

The hydrant lateral length shall be minimized by locating the hydrant on the short side of the water main. Excess fittings shall be eliminated by using full lengths of pipe. Bends in the lateral are prohibited, subject to the discretion of the Engineer.

The hydrant location shall be selected to minimize impacts on neighborhood parking and aesthetics. Hydrants located mid-block shall be placed to straddle extended property lines, so that the hydrant is not located directly in front of one parcel.

If an easement is required for the hydrant location and clearances, the applicant shall prepare the easement using the City's format and language and obtain any necessary survey information. The City shall review and approve the easement before it is finalized.

### **6.5.2 Fire Hydrant Installation**

The Contractor shall install a new fire hydrant where indicated by the Contract Documents or the Engineer. Fire hydrants shall be installed per Detail 10, and these specifications.

The fire hydrant shall connect to the water main via 6-inch diameter lateral pipe. The lateral piping shall consist of DI or PVC pipe installed in accordance with the pertinent sections of these specifications. Every joint on the lateral shall be restrained. The hydrant lateral trench shall be constructed in accordance with Detail 14. The minimum depth of cover is 36 inches. The Contractor shall install a thrust block per Detail 19 at the base of the hydrant bury and behind the tee or tapping sleeve used to connect to the water main.

The hydrant and hydrant bury shall be installed plumb. The hydrant bury shall be properly sized such that the flange face is 2-4 inches above finished grade, and adequate clearance is provided to flange bolts. Flange bolts shall be installed with the bolt shaft pointing down.

Fire hydrants shall be installed with the large 4.5-inch diameter outlet facing the street. Outlet cap chains shall be removed. Fire hydrants shall be painted with "post international yellow" enamel.

Where a hydrant is to be installed outside of concrete sidewalk, the hydrant shall be centered in a 6-inch thick, 4 foot by 4 foot reinforced concrete pad constructed in accordance with the pertinent sections of these specifications and Detail 10.

Where required by the Engineer or the fire agency, the Contractor shall install traffic bollards per Detail 20 and the pertinent section of these specifications.

All related work such as saw cutting, trenching, hot tapping, backfill and paving shall be executed in accordance with the pertinent sections of these specifications.

### **6.5.3 Fire Hydrant Relocation**

When indicated by the Contract Documents or the Engineer, the Contractor shall relocate a fire hydrant. The Contractor shall remove the existing hydrant, and install a new hydrant in accordance with all pertinent sections of these specifications. All new parts shall be used in the installation of said fire hydrant, unless approved otherwise by the Engineer.

## **6.6 Flexible Couplings and Repair Clamps**

With the approval of the Engineer, connections to existing water mains may be made with flexible couplings when the existing main is made of material which will not allow a restrained joint. Such couplings shall be installed in accordance with the manufacturer's recommendations. Care shall be taken to ensure that the pipes are in proper alignment and that smooth surfaces have been provided so that the couplings can be properly fitted. Attention shall be paid to the fact that flexible couplings are not restrained joints. Care shall be taken to not interrupt the required restrained length of an existing pipe in the act of repairing it.

Broken or leaking water mains may be repaired with stainless steel repair clamps. Such clamps shall be installed in accordance with the manufacturer's recommendations and the discretion of the Engineer.

All uncoated areas of flexible couplings, repair clamps, and any non-stainless steel hardware shall be completely covered in bitumastic coating by either brush or spray application to protect against corrosion.

## **6.7 Water Services**

When indicated by the Project Documents or the Engineer, the Contractor shall install a complete service line in accordance with these specifications and applicable Details. A water service shall consist of a hot tap connection to the main, lateral piping, installation of a meter box, all meter-related fittings and pipe, and a backflow prevention assembly where required in accordance with SCWD Policy Statement 3. All related work such as excavation, pavement removal and replacement shall be executed in accordance with the pertinent sections of these specifications.

Water services 2 inches and smaller in diameter shall be installed per Detail 5. Water services 3 inches or 4 inches in diameter shall be installed per Detail 6. Water services 6 inches and larger in diameter shall be installed per Detail 7.

Services may be combined in certain instances with the approval of the Engineer. Combination fire and domestic services for single family dwellings shall be installed per Detail 4. Multiple 1-inch and smaller domestic and irrigation services may be combined per Detail 3.

All water meters, regardless of size, connected to the SCWD system shall be purchased by and remain property of SCWD. Under no circumstances shall anyone other than SCWD personnel remove a water meter once the service has been inspected and approved, unless otherwise directed by SCWD personnel. Customer-owned sub meters are allowed, if located on the customer's side of the City owned meter.

### **6.7.1 Service Lateral Installation**

The Contractor shall make a hot tap connection in accordance with the pertinent sections of these specifications and Detail 1. No service taps shall be made within 18 inches of another service tap, nor within 24 inches of any fitting, bell, or other pipe joint. With the approval of the Engineer, the location of the tap may be offset up to 8 feet horizontally from the meter box location to avoid such obstacles.

The Contractor shall install a service line of size, material and in the alignment indicated by the Contract Documents or the Engineer. Service lines may be laid in an open cut trench or placed through a hole produced by a horizontal jacking or drilling tool. The Contractor shall minimize the number of joints in service lines by using full lengths of pipe.

Service lateral trenches shall be constructed in accordance Detail 14. The minimum cover for services smaller than 6 inches in diameter is 24 inches. The minimum cover for services 6 inches in diameter and larger is 36 inches.

Five feet clear horizontal distance shall be maintained between water service laterals and sanitary sewer laterals. Three feet clear distance shall be maintained between water service laterals and other utility lines. If there is no alternative but to install a sanitary sewer lateral within the minimum clear distance, the Engineer may allow the installation if the sanitary sewer lateral is encased in concrete. Water service laterals shall not be constructed in joint trenches with any other utility.



### **6.7.2 Disinfection**

Service laterals shall be disinfected if required by the Engineer. Disinfection and testing shall be executed in a manner approved in advance by the Engineer.

### **6.7.3 Meter Box Installation**

The Contractor shall install meter boxes in the locations indicated by the contract documents or the Engineer. Meter boxes shall be installed in accordance with Detail 2 and these specifications.

All City-owned meter boxes shall be located within City or County Right-of-Way or in utility easement allowing installation and maintenance of water mains, laterals, and water meters. If an easement is required, the applicant shall prepare the easement using the City's format and language and obtain any necessary survey information. The City shall review and approve the easement before it is finalized.

### **6.7.4 Radio Read Conduit**

Where water meters are installed within 10 feet of other new or existing water meters, the Contractor shall install a conduit between said meter boxes per Detail 2 and these specifications. The ends of the conduit shall rise a minimum of 3 inches above the soil in the meter box. The Contractor shall place tape over the ends of the conduit to prevent soil from entering the conduit. All electronics and wiring shall be installed by city forces.

### **6.7.5 Meter Box Relocation or Service Retrofit**

Where indicated by the Contract Documents or the Engineer, the Contractor shall relocate and/or retrofit a service.

Meter boxes may be offset from the standard location (which is perpendicular to the main), up to 8 feet along the public road right of way. If a meter box must be relocated further than 8 feet from its original location, the service lateral shall be removed and a new service installed in accordance with pertinent sections of these specifications.

The Contractor shall schedule a service line shut down with SCWD a minimum of two working days in advance of the proposed relocation or retrofit. The Contractor shall expose the valve or corporation stop for SCWD personnel to operate. Only SCWD personnel may operate valves or corporation stops. Pipe freezing as a means of temporary shutdown of a service may be allowed at the discretion of the Engineer. In no instance shall service pipe be crimped.

The Contractor shall remove the old meter box, related fittings and lateral piping, and install a new meter box, related fittings and lateral piping in accordance with the pertinent sections of these specifications. The new service shall fully conform to the latest version of these specifications. The extents of lateral piping to be replaced shall be determined solely by the Engineer. All related work such as backfill, paving and site restoration shall be executed in accordance with the pertinent sections of these specifications, and the specifications of the applicable public works agency.

## **6.8 Installation of Backflow Prevention Assemblies**

The Contractor shall install a backflow prevention assembly in the location indicated by the Contract Documents or the Engineer. Backflow prevention assemblies shall be installed in accordance with SCWD Policy Statement 3, the pertinent SCWD Detail(s), and the pertinent sections of these specifications. Backflow prevention assemblies shall remain the property and responsibility of the parcel owner.

Following acceptance of the installation, the assembly shall be performance tested on an annual basis at the owner's expense by a certified tester selected from the SCWD approved list.

### **6.8.1 Location**

The backflow prevention assembly shall be located within 8 feet of the meter to which it is attached. If there is no meter on the service, or if the meter is integral with the assembly, the assembly shall be located within 8 feet of City right-of-way line. The assembly shall be installed such that the device is readily accessible for testing and maintenance. The location of all assemblies shall be approved by the Engineer prior to installation.

### **6.8.2 Assemblies**

Backflow prevention assemblies shall be greater than or equal to the diameter of the service designated by the Engineer. Two or more backflow prevention assemblies may be installed in parallel if a continuous water supply is desired during testing and repairs. In this case, the sum of the cross-sectional areas of the assemblies shall be at least equal to the cross-sectional area of the service connection.

### **6.8.3 Protective Cover or Cage**

If the assembly is installed where vandalism or damage due to freezing may be a problem, the unit may be protected and secured at owner's expense. Handles of valves may be removed to discourage tampering. Alternatively, a protective cage or cover can be installed over the unit.

In cases where the water meter is to be installed above-ground, integrated with the backflow prevention assembly, the water meter shall be protected with a locking enclosure approved in advance by the Engineer.

Cages shall be installed so that adequate clearance is available for maintenance and testing or that the cage is completely removable. The Contractor shall allow for any discharge from the relief valve to fully drain from the protective cage or cover.

## **6.9 Pipe Location Wire**

The installation of non-metallic water main shall include a coated, stranded ten gauge copper wire taped directly on the pipe per Detail 15 and these specifications.

The wire shall be taped to the top of the pipe using duct tape at intervals not exceeding 20 feet. The interval may be decreased by the Engineer to ensure that the wire remains securely in place during backfill operations.

The copper wire shall be continuous. If continuity is not possible, the Engineer may allow wire to be spliced by soldering. Soldered joints shall be made in a workmanlike manner to ensure long term mechanical strength and electrical continuity. The wire shall be heated, flux applied, and the solder shall be melted by the hot wire, such that the solder flows readily into the wire strands. The joint shall not be moved until it has cooled. Joints that are cloudy in appearance shall be reheated so that they are shiny. The soldered joint shall be wrapped in vinyl electricians tape or heat-shrink tubing.

Pipe location wire shall be brought up on the outside of all valve box riser pipes, and held in place inside the valve box by wedging it securely between the valve box and the riser pipe or in a vertical slot cut in the top of the riser pipe per Detail 11. Pipe locating wires shall not be installed in contact with metal valve key extensions or other metal pipes or appurtenances.

## **6.10 Chlorination Tap**

Where indicated by the Contract Documents or the Engineer, the Contractor shall install a chlorination tap per Detail 22, and these specifications. The chlorination tap shall be centered in the meter box. Chlorination taps shall not be located further than 10 feet downstream of the beginning of the section to be chlorinated.

## **6.11 Pressure Regulating Station**

The Contractor shall install pressure regulating stations at the locations indicated by the Contract Documents or where directed by the Engineer. In saturated ground, the pressure regulating station vault shall be located in a shed of design approved by the Engineer. Pressure regulating stations installed below ground shall include a drain from the vault. The station vault shall be easily accessible with ladder rungs mounted in vaults deeper than 3 feet. The station shall have an H/20 load rating, vaulted, padlock-capable aluminum lid with a gooseneck type screened vent. All exposed pipe and fittings shall be painted with non-VOC epoxy paint or with 2 coats of rust preventative enamel.

## **6.12 Sample Station**

The Contractor shall install sample stations at the locations indicated by the Contract Documents or where directed by the Engineer. The stations shall be installed as indicated on Detail 21. The station shall be easily accessible. All exposed pipe and fittings shall be painted with "hunter green" non-VOC epoxy paint or with 2 coats of rust preventative "hunter green" enamel.

## **6.13 Appurtenant Concrete Work**

The Contractor shall install plain and reinforced concrete required for construction of appurtenances where indicated by the Contract Documents, or the Engineer. Concrete work shall conform to current applicable ACI standards. Concrete for thrust blocks, reverse anchors, post embedment, and concrete collars may be hand mixed on site.

The ground against which concrete is to be placed shall be moistened previous to placement so that it will not absorb excessive moisture from the green concrete. Forms required shall be smooth, mortar tight and of sufficient strength to maintain shape during the placement of the concrete. Placement methods shall be such that the concrete will be placed in its final position without segregation. All concrete shall be rodded and spaded to ensure smooth surfaces along form lines and to eliminate rock pockets. The use of mechanical vibrators is not required on anchors and valve supports.

Concrete shall not be placed in free water. Pumping from the interior of any foundation enclosure shall be done in such a manner as to prevent the concrete from being carried away. No pumping will be permitted during the placing of concrete, or for a period of 24 hours thereafter, unless it is done from a suitable sump separated from the concrete. Water shall not be allowed to rise on any concrete until the concrete has attained its initial set.

### **6.13.1 Thrust Blocks and Reverse Anchors**

The Contractor shall install thrust blocks at all fittings where indicated by the Contract Documents or where required by the Engineer. Thrust blocks on fittings 10 inches in diameter and smaller shall be installed per Detail 19. Thrust blocking on fittings larger than 10 inches in diameter, at depths less than 36 inches, or in poor soils shall be designed on a case-by-case basis. Designs shall be approved by the Engineer prior to construction.

### **6.13.2 Fire Hydrant and Backflow Prevention Device Concrete Pads**

Where a fire hydrant is to be installed outside of paved sidewalk area, or when required by the Engineer, the Contractor shall install a reinforced concrete pad per Detail 10. Backflow prevention devices shall be installed in a reinforced concrete pad in accordance with the applicable SCWD Detail.

Concrete pads required for fire hydrant installations shall be reinforced. Reinforcing steel shall consist of #3 rebar placed at 12 inches on center, each way, or welded steel wire mesh of equivalent cross sectional area. Reinforcing steel shall be centered vertically in the concrete. Three inches minimum clearance shall be maintained between the edge of the concrete and reinforcing steel on all sides. Concrete pads shall be sloped away from the hydrant bury such that water is prevented from ponding adjacent to the pipe.

Reinforcement of Concrete pads for backflow prevention devices shall be installed as specified above for fire hydrant pads or as indicated by the Contract Documents.

### **6.14 Traffic Bollard Installation**

Where indicated by the Contract Documents or the Engineer, the Contractor shall install a traffic bollard per Detail 20, and these specifications.

Traffic bollards shall be installed plumb and shall be four feet tall unless otherwise directed by the Engineer. The concrete foundation or paving at the base of the bollard shall be sloped away from the steel pipe such that water is prevented from ponding adjacent to the pipe. The traffic bollard shall be painted with "post international yellow" enamel unless it is protecting a private fire hydrant or backflow device, in which case it may be painted to match the device. Traffic bollards shall have a 6-inch tall reflective strip placed near the top of the bollard after it is painted.

## **7 Backfill and Paving**

### **7.1 General**

Before backfilling, the trench shall be cleared of all debris and deleterious material such as wood blocks, grade stakes, paper, rope, rags, rocks and pavement chunks. Care shall be taken to ensure that the material used for backfilling is free from such debris.

Following completion and acceptance of the backfill, the area shall be paved in accordance with these specifications and Details 14 or 15 as soon as possible.

Unless otherwise approved by the Engineer, no more than 50 feet of trench shall be open and plated at the end of each work day.

### **7.2 Backfill**

Trenches within the City limits shall be backfilled in accordance with these specifications and Details 14 or 15. Backfill of trenches outside of the city limits shall conform to the County of Santa Cruz Public Works Trench Backfill Standards, Figures EP-1, EP-2, and EP-3. This requirement applies to all pipelines, services and other excavations in conjunction with the project.

The Contractor shall in general, install pipe at the standard depth of 36 inches. Where there is no reasonable alternative but to install water main or water services 6 inches and larger with less than 36 inches of cover, a 12-inch thick concrete cap shall be constructed in place of standard backfill, and class 350 or better DI pipe shall be installed per Detail 16. Prior approval of the Engineer is required to install pipe in this manner.

Backfill material shall not be placed over or around any fitting, thrust block, restrained joint, or cathodic protection system component until the object has been inspected and approved by the Engineer. After completion of the installation of the pipe and appurtenances to the satisfaction of the Engineer, the remainder of the trench shall be backfilled.

During the process of backfilling, any timbering, sheeting, shoring or sheet piling used to shore the excavation shall be carefully removed in such a manner as will result in a minimum of caving, lateral movement or flowing of the soil.

#### **7.2.1 Backfill Placement**

Unless approved otherwise by the Engineer, the Contractor shall place and tamp a sand bedding prior to laying pipe in accordance with Details 14 or 15.

The sand backfill immediately surrounding the pipe (pipe-zone) shall be brought up evenly on each side of the pipe and thoroughly tamped in place. Installation of PVC pipe requires that the material from the bottom of the pipe to the spring line of the pipe (haunching) be hand-tamped to the satisfaction of the Engineer. Pipe-zone sand backfill shall cover the pipe by the depth indicated by the appropriate Detail or the Engineer. Pipe-zone sand shall be moisture conditioned and uniformly compacted to 90% relative compaction.

The remaining portion of the backfill extending from the top of the sand to the underside of the paving (trench zone) shall consist of aggregate base. Trench-zone aggregate base shall be moisture conditioned and uniformly compacted to 95% relative compaction.

Trench-zone backfill for service laterals shall be controlled low strength material (CLSM) unless approved otherwise in advance by the Engineer.

With approval of the Engineer, tunneling for short distances under existing facilities, sidewalks and pavement may be allowed. Tunneled sections shall be backfilled with CLSM.

The final lift of backfill material in trenches through unpaved areas shall consist of topsoil similar to that removed, or other material approved by the Engineer, compacted to 90% relative compaction.

### **7.2.2 Compaction Methods**

The Contractor shall compact backfill by mechanical means, using equipment approved by the Engineer. The maximum loose-placed lift thickness shall be as determined by the Engineer, based on the type of compaction equipment used, and the observed quality of the work. Native soils are generally not free draining, thus hydraulic compaction methods are prohibited.

### **7.2.3 Compaction Testing**

The Contractor shall verify the compaction of all backfill material installed. The number of tests required shall be determined by the length of the trench divided by 50 feet. However, the intervals between compaction tests, and the locations of the tests shall be as determined by the Engineer.

The Contractor shall provide the name, contact information and provide the qualifications of an independent Geotechnical Engineering Firm who is routinely engaged and fully qualified to conduct the confirmation tests specified. The laboratory shall be approved in writing by the Engineer prior to the start of any backfill operations. All costs of materials and confirmation testing shall be borne by the Contractor.

The maximum dry density of each type of backfill material shall be submitted to the Engineer as part of the materials submittal. Copies of the field test reports shall be submitted to the Engineer prior to paving, upon request of the Engineer, or upon acceptance of the work.

If indicated by the Contract Documents or the Engineer, The City will retain the services of a geotechnical engineering firm, and coordinate all compaction testing. In this case, The Contractor will not be relieved of the duty of providing work which complies with these specifications. The Contractor shall coordinate their work schedule with the Engineer such that the work is accessible to the City's compaction tester. No compensation will be provided to the Contractor for construction delays due to compaction testing. The Contractor shall not base any damage claims or time extension requests upon delay related to compaction testing. No compensation will be provided to the Contractor for work or materials that must be removed and replaced to provide proof of compliance with these specifications.

If any compaction test reveals sub-standard compaction, or if the Engineer observes evidence of sub-standard compaction, the Contractor shall replace and/or re-work the backfill material within the limits designated by the Engineer. The re-worked area shall be re-tested in the location(s) designated by the Engineer. All remedial work shall be done at no cost to the City.

## **7.3 Paving**

Following the Engineers acceptance of the backfill, roadway and/or sidewalk paving shall be replaced in kind wherever it has been removed. Paving which has been damaged by operations of the contractor shall be replaced in kind per these specifications at no expense to the City. The materials and methods used for paving shall conform to the specifications of the appropriate public works agency and shall be approved by the Engineer. The final surface attained shall be subject to the approval of the Engineer.

Permanent surfacing material shall be placed on the base as soon as possible after backfilling is accepted. Prior to replacing the pavement, the edges of the existing pavement shall be neatly saw cut to a vertical plane and in straight lines. If the existing pavement was previously saw cut and the condition of

edges has deteriorated, the Contractor shall saw cut new edges at no expense to the City. The edges shall be thoroughly cleaned of all mud, dirt and dust before placing the surface material.

All traffic striping (centerlines, fog lines, lettering, etc.) shall be replaced in-kind. Thermoplastic striping shall be applied if required by the Engineer.

### **7.3.1 Asphalt Concrete Paving**

The roadway surfacing shall be replaced to a depth equal to the existing depth, but not less than 3 inches.

The edges of the existing pavement shall be completely coated with an asphaltic emulsion by spraying. Brushes or daubers shall not be used.

Proper asphalt temperature shall be maintained during paving operations. Hot mix asphalt shall come off the truck at a temperature greater than 275 degrees Fahrenheit. Spread and breakdown of the asphalt shall be completed before the asphalt cools below 200 degrees Fahrenheit. The paving shall be finished before the asphalt cools below 150 degrees Fahrenheit. Asphalt shall not be placed if the temperature of existing pavement adjacent to the area to be paved is less than 50 degrees Fahrenheit.

The completed surfacing shall be thoroughly compacted by power roller and shall be free from ruts, bumps, depressions or irregularities. A seal coat shall be applied if required to match the surface texture of the existing pavement. The final pavement surface shall transition smoothly to the existing pavement.

The Contractor shall fill all saw cuts with sand and seal with an asphalt crack sealant approved by the Engineer.

If there will be a delay in final paving, a temporary 1-inch thick asphaltic plant mix surface shall be placed immediately after backfilling has been completed and removed just prior to placing the permanent surfacing material. Until the permanent surfacing material is placed, the base rock or temporary asphaltic plant mix at the surface of the trench shall be maintained at all times at a grade level with the adjacent street.

### **7.3.2 Portland Cement Concrete Paving**

The edges of the existing pavement and the surface of the base material shall be thoroughly wetted just prior to placing new concrete.

Concrete paving shall be 6 inches minimum thickness unless specified otherwise by the Engineer. Concrete shall be placed to match all existing expansion joints and deep scores. Concrete shall be edged with a ¼ inch chamfer. Concrete paving shall be reinforced with #4 rebar dowels placed at 24 inches on center, each way. Reinforcing steel shall be centered vertically in the pavement section. Reinforcing steel shall be embedded a minimum of 6 inches into adjacent portland cement concrete paving. Concrete certification tickets shall be submitted to the Engineer.

## **8 Removal and Abandonment**

### **8.1 Valves**

Valves appurtenant to water mains which are to remain in service shall be removed in accordance with these specifications when no longer needed. In-place abandonment of valves attached to mains which will remain in service is not allowed. Valves appurtenant to water mains to be abandoned may be abandoned in place in accordance with these specifications.

#### **8.1.1 Valve Removal**

The water system shall be shut down in accordance with the pertinent sections of these specifications.

The Contractor shall remove the valve, valve box, lid, riser pipe, concrete collar, and associated components. If the valve is attached directly to a flanged or mechanical joint fitting or tapping sleeve, the valve shall be removed and replaced with a blind flange or mechanical joint plug. If the valve is inline, or attached to an unrestrained fitting, the pipe, fitting and valve shall be neatly cut out, removed completely, and replaced with a new section of pipe. The system shall be re-pressurized and the Engineer shall inspect for leaks prior to backfilling.

All related work such as saw cutting, trenching, pipe installation, backfilling, and paving shall be executed in accordance with the pertinent sections of these specifications. If tracer wire is present, care shall be taken to maintain its continuity. If tracer wire is not continuous, it shall be spliced in accordance with the pertinent sections of these specifications.

The water system shall be re-pressurized, flushed, and sampled in accordance with the pertinent sections of these specifications.

#### **8.1.2 Valve Abandonment**

The Engineer shall confirm that the valve is closed. The Contractor shall remove the valve box, lid, concrete collar, and associated components, leaving the riser pipe in place. The hole above the valve shall be filled with slurry or concrete up to the bottom of the pavement section. All related work such as saw cutting and paving shall be executed in accordance with the pertinent sections of these specifications.

### **8.2 Pipeline Abandonment**

The Contractor shall plug the ends of all abandoned pipelines where they have been cut open by the Contractor. This requirement applies to pipelines that the Contractor abandons, and to existing abandoned pipelines that the Contractor has cut to make way for new facilities.

Abandoned pipelines shall be plugged with concrete. The concrete shall be compacted into the pipe so that it forms a complete seal around the entire circumference of the pipe. Pipes abandoned in areas of steep slope or excessive groundwater may require additional plugging or grouting at the discretion of the Engineer.

### **8.3 Fire Hydrant Removal**

The Contractor shall remove Fire Hydrants indicated for removal on the Contract Documents or by the Engineer. The fire hydrant bury shall be removed to a minimum 2 feet below grade and plugged with concrete. The concrete shall be compacted into the bury so that it forms a complete seal around the entire circumference of the pipe. Valves, valve boxes, paving and sidewalk shall be removed and/or



replaced in accordance with the pertinent sections of these specifications. Salvaged hydrants shall be delivered to the City at the Corporation Yard at the request of the Engineer.

The Engineer shall notify the local fire agency when hydrants are removed from or put into service.

#### **8.4 Service Abandonment**

The Contractor shall schedule a service line retirement with SCWD a minimum of two working days in advance of the proposed retirement. The Contractor shall expose the valve or corporation stop for SCWD personnel to operate. Only SCWD personnel may operate valves or corporation stops.

For service laterals attached to the main with a corporation stop, the service lateral shall be disconnected from the corporation stop by removal of the FIPxGrip Joint Adapter. The male iron pipe threads on the corporation stop shall be cleaned and prepared with tape and/or dope. A brass cap shall be tightened onto the corporation stop to prevent possible leakage. Older services that do not have MIP corporation stops shall be capped in another manner acceptable to the Engineer. The remaining service line shall be removed to a minimum depth of two feet.

For service laterals without corporation stops, the service lateral shall be disconnected from the valve, and the valve removed in accordance with the pertinent sections of these specifications. The remaining service line shall be removed to a minimum depth of two feet near the meter box and plugged with concrete in accordance with the pertinent sections of these specifications.

The meter box, related fittings and piping shall be removed. If the box is located in a sidewalk, the sidewalk shall be neatly saw cut and replaced at the nearest joint. All related work such as backfill, paving and site restoration shall be executed in accordance with the pertinent sections of these specifications, and the specifications of the applicable public works agency.

## **9 Pressure and Leakage Testing**

### **9.1 Pressure and Leakage Tests**

After the pipe has been laid and backfilled, the pipe, or any valve section thereof, shall be pressure tested in accordance with these specifications and applicable AWWA Standards.

Pressure and leakage tests shall not be performed until 72 hours have elapsed since the last concrete thrust block or reverse anchor has been cast, unless temporary blocking or other restraints have been provided to the Engineer's satisfaction.

Connections to the existing system, not included in the pressure and leakage tests shall be visually inspected for leakage while under pressure prior to being fully backfilled in accordance with the pertinent sections of these specifications.

### **9.2 Pressure Test Procedure**

The extent of new piping and number of appurtenances to be tested at one time shall be determined by the Engineer. In the case of systems with new services, the pressure test shall include all service piping up to the angle meter stop.

The water main shall be slowly filled with water through a SCWD provided hydrant meter or other backflow prevention device approved by the Engineer. Air shall be vented from all high points in the water main before making any pressure tests. Pipe shall be filled with water and pressurized at least 24 hours prior to testing to allow air to escape.

Where temporary bulkheads are used to test isolated portions of steel mains with O-Ring joints, the joints downstream from the temporary bulkhead will be welded in accordance with these specifications.

The test pressure shall be one and a half times the operating pressure at the average elevation, or 155 psi, whichever is greater. Where there are large changes in water main elevations, the test pressure will be determined by the Engineer.

The pressure shall be applied by means of a pump or backflow-protected jumper connection connected to the main in a manner satisfactory to the Engineer. The pressure shall be measured at the point(s) determined by the Engineer.

All materials and labor required for performing the pressure test shall be furnished by Contractor at no expense to City. The Engineer may check the test pressure by installing a SCWD test gauge in place of or in addition to the Contractor's gauge. In case of a discrepancy between gauges, the Engineer's decision shall be final.

The hydrostatic pressure test shall be 2 hours duration. The allowable pressure drop is 5 psi, subject to the discretion of the Engineer.

With prior approval from the Engineer, the Contractor may at his convenience conduct a preliminary pressure test at any time prior to the SCWD pressure test. The results of the preliminary test will not be considered by the Engineer.

### **9.3 Leakage Test Procedure**

A leakage test shall be performed if the pressure test reveals any observable pressure drop, or at the discretion of the Engineer.

The Contractor shall furnish the pump, pipe, connections and all other necessary apparatus and shall furnish all necessary assistance to conduct the test. SCWD may check the test pressure by installing a SCWD test gage in place of Contractor's gage. In case of a discrepancy between gauges, the Engineer's decision shall be final. The duration of the leakage test shall be 2 hours, and may be conducted at the same pressure as the pressure test. The pressure test and leakage test may be combined.

Leakage is defined as the quantity of water to be supplied into the newly-laid pipe, or any valved section thereof, necessary to maintain the specified leakage test pressure after the pipe has been filled with water and the air expelled. The Engineer shall measure the quantity of water added to maintain the specified leakage test pressure.

No pipe installation shall be accepted by the Engineer until the leakage is less than the number of gallons per hour as determined by the applicable formula.

$$L = \frac{ND\sqrt{P}}{7400} ; \quad \text{for PVC Pipe}$$

$$L = \frac{ND\sqrt{P}}{3700} ; \quad \text{for DI Pipe}$$

In which  $L$  equals the allowable leakage in gallons per hour;  $N$  is the number of joints in the length of pipeline tested;  $D$  is the nominal diameter of the pipe in inches; and,  $P$  is the average test pressure during the leakage test in pounds per square inch gauge. Allowable leakage for other pipe materials will be to the discretion of the Engineer.

Leakage is typically measured by leaving the pump used to conduct the pressure test attached to the main. At the end of the required two hour duration, the calculated acceptable leakage volume is placed in the feed bucket for the pump. The main is then pumped back up to the pressure at which the test began. If the water in the bucket runs out before the test pressure is reached, the main fails. The City may provide a meter when small leakage quantities must be measured accurately.

#### **9.4 Test Failure**

Should the main fail either test, the Contractor shall, at no expense to the City, locate and repair defects in the work or materials until the pipe is able to pass both tests. All repair work shall be executed in accordance with the pertinent sections of these specifications.

## **10 Disinfection and Testing**

### **10.1 General**

All water mains shall be successfully disinfected, flushed and verified in accordance with these specifications prior to connection to the existing system and prior to making service connections. SCWD personnel shall perform all flushing and disinfection operations. The Contractor shall provide safe site access to SCWD personnel and maintain site conditions in accordance with the pertinent sections of these specifications. The first round of flushing, chlorination and testing operations will be completed at no expense to the Contractor.

The Contractor shall provide a minimum of 2 working days advance notice to SCWD when the main is ready for chlorination, unless approved in advance by the Engineer. Chlorination will only be conducted on Mondays and Tuesdays.

### **10.2 Disinfection of Mains**

SCWD shall disinfect, test, flush and re-flush new water lines in accordance with AWWA Standard C651, and these specifications. The Contractor shall not make any connections to the pipeline until the pipeline has passed all laboratory tests.

### **10.3 Disinfection of Services**

Service laterals shall be disinfected if required by the Engineer. Disinfection and testing shall be executed in a manner approved in advance by the Engineer.

#### **10.3.1 Chlorination of New Pipelines**

Water required for chlorination and flushing may be obtained from the existing system by use of a jumper connection. The jumper connection shall be equipped with a backflow prevention device.

The main shall be flushed prior to chlorination. The water velocity inside the pipe shall not be less than 2.5 feet per second.

The new main and appurtenances shall then be chlorinated. The method of application and precautions outlined in AWWA Standard C651 shall be followed, subject to the discretion of the Engineer. Chlorine shall be applied by the continuous feed method or slug method as outlined in AWWA Standard C651 except as modified by SCWD or the Engineer.

When the continuous feed method is used, chlorine solution shall be fed into the pipe and left in contact with the pipe for no less than 24 hours. The initial free chlorine concentration shall be no less than 25 ppm. The concentration of free chlorine at the end of the contact time shall not be less than 40% of the starting concentration

The chlorine solution shall be flushed from the water main. Super-chlorinated water shall be dechlorinated before being discharged to storm drains or waterways. Super-dechlorinating is not necessary when discharging to a sanitary sewer. Flushing shall continue until the chlorine residual is less than 1 ppm, or typical system residual at that location, and turbidity is less than 0.5 NTU.

#### **10.3.2 Urgent Disinfection**

If the Engineer deems it necessary to disinfect a pipeline which must be returned to service at the end of the day, such as in the case of an existing pipeline which has become contaminated during an

existing system connection (tie-in), the Contractor shall suspend any construction activities requested by the Engineer and coordinate with the Engineer to ensure that the contaminated water line is disinfected to the satisfaction of the Engineer before being returned to service. All disinfection procedures shall be executed as determined by the Engineer

If in the opinion of the Engineer, an urgent disinfection is necessary due to reckless, incompetent or unclean construction practices on the behalf of the Contractor, the actual cost of said urgent chlorination plus standard overhead may be deducted from payments due to the Contractor from the City. No compensation of any kind shall be provided to the Contractor by the City for construction delays due to urgent disinfection. The Contractor shall not base any damage claims or time extension requests on any delays due to urgent disinfection.

## **10.4 Disinfection Testing**

Following disinfection of the main, SCWD shall secure samples of the water from the water main for laboratory examination in accordance with AWWA Standard C651, and these specifications. Two sets of samples shall be collected, 24 hours apart.

Samples shall be taken from blow-offs or fire hydrants installed on the water main. Two samples for bacteriological (Bacti) testing and one sample for general physical (GP) testing shall be taken from each sampling point by SCWD. The sampling line may remain in place until testing produces satisfactory results or may be removed between samplings. If the sample pipe is left in place, the end of the pipe should be capped to prevent the entrance of dust or other contamination.

SCWD will notify Contractor of the results of the tests. Should either of the initial Bacti test samples indicate the presence of coliform bacteria or should any of the GP tests fail, flushing and sampling (both bacteriological and GP) shall be repeated once. If isolated sample points indicate coliform bacteria, flushing and re-sampling of only those points may be approved by SCWD. If satisfactory results are unachievable, the main must be re-chlorinated and re-sampled. After re-chlorination, if satisfactory results are still unachievable, the Contractor shall locate and remove the source of contamination. All remedial work shall be executed in accordance with the pertinent sections of these specifications.

If in the opinion of the Engineer, additional chlorination, flushing and testing is necessary due to reckless, incompetent or unclean construction practices on the behalf of the Contractor, the actual cost of said additional chlorination or flushing plus standard overhead may be deducted from payments due to the Contractor from the City. No compensation of any kind shall be provided to the Contractor by the City for construction delays due to these requirements. The Contractor shall not base any damage claims or time extension requests on any delays due to these requirements.

After the disinfection produces satisfactory results, all temporary taps shall be securely closed and all sampling pipes removed. See Section 12.3 of these Specifications.

### **10.4.1 Special Additional Testing Requirements**

If trench water enters the pipe during construction, or if in the opinion of the Engineer, the interior of the pipe is contaminated or excessively dirty, the Special Testing Procedures described in this section shall be followed.

The new main shall have been chlorinated and flushed by SCWD in accordance with these specifications. After final flushing and sampling, water shall be allowed to stand in the pipe for not less than 16 hours. After 16 hours have elapsed, samples of the water which stood in the pipe shall be taken at 200' intervals. The water main shall not be flushed out prior to this special sampling. Samples may be taken by attaching a meter to the outlet blow off, and taking one GP and two Bacti samples at each volume increment corresponding to 200' of pipe length.

If in the opinion of the Engineer, said Special Testing Procedures are required due to reckless, incompetent or unclean construction practices of the Contractor, the actual cost of said special testing plus standard overhead may be deducted from payments due to the Contractor from the City. No compensation of any kind shall be provided to the Contractor by the City for construction delays due to these special testing requirements. The Contractor shall not base any damage claims or time extension requests on any delays due to these requirements.

### **10.5 Contractor's Responsibility for Disinfection and Testing**

Notwithstanding anything contained herein, it shall be the sole responsibility of Contractor to construct a water main capable of passing the pressure and leakage tests. The fact that SCWD provides inspection during the construction and pressure testing, conducts the disinfection testing, and performs laboratory testing of the water mains shall not abrogate Contractor's responsibility in this regard.

It shall also be the responsibility of the Contractor to prevent the consumption of unsafe water by any person from a main which has not been determined to be safe by SCWD through disinfection and testing in accordance with these specifications. The Contractor shall indemnify and hold SCWD harmless from any suits, claims, or actions brought by any person or persons for or on account of any sickness or death sustained or arising from the consumption of water from any such main.

## **11 Work on the Existing System**

### **11.1 Advance Notice of Shut Down**

The Contractor shall request a system shut down at least 3 working days prior to the proposed commencement of any work which requires that the existing system be shut down. The Engineer shall determine the date, time and duration of the shutdown. If indicated by the Engineer, the Contractor shall hang SCWD-provided notification tags on the front door of each affected dwelling or place of business 3 working days in advance of the shut down. In general, shutdowns will be kept as short as possible and shall be made at times when there will be the least interference to the customers.

### **11.2 Operation of the Existing System**

SCWD personnel shall close all valves in making a shutdown, open all valves in restoring pressure, and otherwise operate the existing system exclusively. The Contractor shall not operate any part of the existing system.

In the event that the Contractor operates the existing system and either directly damages the system, or in the opinion of the Engineer, causes indirect damage to the system, public or private property by causing the system to operate incorrectly, the costs for all repairs shall be borne by the Contractor. The Contractor shall pay the actual cost of repairs plus standard overhead. Such costs may be deducted by the City from any monies due or to become due to the Contractor under the Contract. No compensation of any kind shall be provided to the Contractor by the City for construction delays due to repair of the existing system by City forces. The Contractor shall not base any damage claims or time extension requests on any delays due to these requirements.

Any claims against the City and any fines levied to the City as a result improper system operation caused by the Contractor shall be borne by the Contractor. Such costs may be deducted by the City from any monies due or that will become due to the Contractor under the Contract.

### **11.3 Preparation**

When work requires a system shut down, the Contractor shall prepare for such work as much as possible in advance. This preparation shall include but not be limited to potholing to determine the exact diameter and location of existing facilities, and having on site all parts and equipment necessary to complete the work. The system will be shut down only when the Contractor has made such preparations to the satisfaction of the Engineer.

### **11.4 Dewatering Operations**

Prior to opening existing mains to make connections or repairs, mains shall be allowed to drain as much as possible through nearby hydrants or blow offs. The Contractor shall excavate a sump sufficiently deep to receive the residual water in the mains per Detail 17. Water shall be pumped out of the sump hole at a rate sufficient to prevent trench water from entering the mains. The Contractor shall ensure that pumps for trench dewatering are operational, primed, and otherwise properly set up and ready to begin pumping immediately at the moment of the main opening.

Water within the sump shall not be allowed to backflow into the water mains after it comes into contact with the trench. Should contaminated water flow into the system, the system shall be flushed and chlorinated as deemed necessary by the Engineer and in accordance with the pertinent sections of these specifications.

The Contractor shall prevent sediment laden trench water from being transported to storm drains or water bodies in accordance with the pertinent sections of these specifications. When practical, the Contractor

may prevent the water flowing into the trench from coming in contact with the earth in the trench. This may be achieved by placing a bucket underneath the draining water main and pumping out of the bucket. Water which is isolated from the trench in this manner may be dechlorinated and discharged directly to gutters or storm drains.

## **11.5 Leakage Inspection**

Connections to the existing system and existing system repairs where proper pressure and leakage tests are not practical, shall be visually inspected by the Engineer for leakage while under pressure prior to being fully backfilled. Where conditions make such visual inspection unsafe, the Contractor shall install a temporary metallic pipe or conduit from all fittings to the ground surface to facilitate listening for leakage. Such temporary pipe shall be completely removed and the backfill recompacted prior to compaction testing and final paving

## **11.6 Tie-Ins**

Upon passing the Bacti and GP tests, the Contractor shall make permanent connections between the new main and the existing system at the locations indicated by the Contract Documents or the Engineer. Advance notice shall be given to all customers affected, the system shall be shut down, drained, and connections made in accordance with the pertinent sections of these specifications.

In general, connections between new and existing mains will be made while the system has been shut down in accordance with the pertinent sections of these specifications, unless the Contract Documents call for a hot tap connection.

### **11.6.1 Connection Procedure**

Where existing mains have been provided with fittings for the purpose of connecting to the new main, the Contractor shall remove any plugs or bulkheads, clean the ends, prepare them for connection to the new main and make the new joint in accordance with the pertinent sections of these specifications. Connections to existing mains shall be a minimum of 24 inches from other taps or fittings, as measured from outside edges.

All joints and fittings used in the connection shall be restrained in accordance with pertinent sections of these specifications, and Details 17 and 18. Flex couplings shall only be used in situations where restrained fittings cannot be used.

The Contractor shall install thrust blocks at all fittings used in the connection in accordance with pertinent sections of these specifications and Detail 19.

All pipe and fittings used to make the connection shall be cleaned and disinfected with a swab saturated with hypochlorite solution or by another means approved by the Engineer.

If possible, after the connection is complete and before backfilling, the connection shall be pressurized and the Engineer shall inspect all joints made during the system connection for leaks. If any leaks are found, they shall be repaired in accordance with pertinent sections of these specifications.



## Section 2 Material Specifications

### 1 General

#### 1.1 Scope

The purpose of Part II Material Specifications is to set forth the materials to be used in the construction of facilities which will become the property of SCWD. Any deviation from these standards must be approved by the Engineer.

All Materials in contact with potable water shall conform to the applicable AWWA Standard, and shall be certified by a ANSI accredited organization to be in compliance with NSF/ANSI 61.

#### 1.2 General

All Materials shall be new and unused. Contractor shall install all materials as indicated on the drawings and specifications and consistent with the project material submittals. All materials delivered to the job site shall be adequately housed and protected to ensure the quality of the project.

The Contractor shall furnish, at the request of the Engineer, without additional cost to the City, such quantities of construction materials required for test purposes.

The SCWD reserves the right to direct or deny use of certain types of materials in specific circumstances.

#### 1.3 Pre Approved Products

Some sections of these specifications list *Pre Approved Products*. These products are listed to provide an example of a material or part which SCWD has found to meet the requirements of these specifications. No preference toward a particular brand, series or model is implied by the *Pre Approved Product* listing.

## **2 Pipe**

### **2.1 Brass Pipe**

Brass pipe and nipples shall conform to AWWA C800 and these specifications and shall be certified by an ANSI accredited organization to be in compliance with NSF/ANSI 61. Brass parts shall consist of brass alloy having a lead content not more than 0.25 percent by weight. Brass shall meet the composition, chemical and mechanical requirements of C89520 or C89833 alloys as specified by the Copper Development Association, Inc.

Brass pipe shall be suitable for use at pressures not less than 150 psi.

#### **2.1.1 Joints**

Joints between brass pipe and adjacent fittings shall be iron pipe threaded. Soldered joints are prohibited.

### **2.2 Copper Pipe**

All below-ground copper pipe shall be type K annealed (soft) seamless copper tubing conforming to ANSI/ASTM B88M and AWWA C800. Copper pipe that is kinked or has walls which have buckled shall be rejected and removed from the site.

Copper pipe used for aboveground piping such as risers for backflow prevention devices shall be type K drawn (hard) seamless copper tubing.

#### **2.2.1 Joints**

Joints in copper pipe shall be made with brass CTS grip joint fittings conforming to pertinent sections of these specifications. Soldered or flare joints are prohibited.

### **2.3 Ductile Iron Pipe**

Ductile iron pipe shall conform to AWWA C151. The wall thickness of the ductile iron pipe shall be designed in accordance with AWWA C150. The class or nominal thickness, net weight without lining, and casting period shall be clearly marked on each length of pipe. Sticks of ductile iron pipe shall have standard lengths of either 18 feet or 20 feet. Random lengths are not acceptable.

#### **2.3.1 Interior Lining**

The interior of ductile iron pipe shall be cement mortar lined and bituminous seal coated in accordance with AWWA C104.

#### **2.3.2 Exterior Coating**

The exterior of ductile iron pipe shall have an asphaltic coating conforming to AWWA C151.

#### **2.3.3 Polyethylene Encasement**

Polyethylene Encasement for wrapping DI pipe shall conform to AWWA C105. Polyethylene wrap shall be clearly marked ANSI A21.5 / AWWA C105. Polyethylene wrap shall be 10-mil thick and provided from the factory in tube form. Sheets may be allowed at the discretion of the Engineer for encasing appurtenances.

### **2.3.4 Joints**

Joints in DI pipe and shall be push-on, mechanical, or flanged rubber gasket joints conforming to AWWA C111. Rubber gaskets and gasket lubricant shall be certified by an ANSI accredited organization to be in compliance with NSF/ANSI 61, and shall not impart taste or odor to water.

Push-on rubber gasket joints shall use the gasket provided by the factory for that particular joint. Swapping gaskets is not allowed.

Mechanical joint glands shall consist of ductile iron conforming to ASTM A536 and shall be protected from corrosion by a quality factory-applied coating. Nuts and bolts for mechanical joints and flanged joints shall either be stainless steel or protected against corrosion by a field-applied bitumastic coating approved by the Engineer.

*Pre Approved Products:*

*Tyton Joint Pipe as manufactured by U.S. Pipe*

Mechanical Joint Pipe as manufactured by U.S. Pipe

## **2.4 Polyvinyl Chloride Pipe**

PVC pipe 4 to 12 inches in diameter shall conform to AWWA C900, be rated for a working pressure of 305 psi, and shall have an outside diameter to wall thickness dimension ratio of 14.

PVC pipe 14 to 48 inches in diameter shall conform to AWWA C905, be rated for a working pressure of 235 psi, and shall have an outside diameter to wall thickness dimension ratio of 18

Each length of pipe shall be clearly marked with the applicable AWWA Standard, Pressure class, and dimension ratio. Sticks of PVC pipe shall have standard lengths of 20 feet. Random lengths are not acceptable.

Pipe which appears discolored or oxidized, or has gouges deeper than 10% of the wall thickness shall be rejected and removed from the job site.

### **2.4.1 Joints**

Joints in PVC pipe shall be push-on rubber gasket joints conforming to AWWA C900 or C905 as applicable. Rubber gaskets and gasket lubricant shall be certified by an ANSI accredited organization to be in compliance with NSF/ANSI 61, and shall not impart taste or odor to water.

Push-on rubber gasket joints shall use the gasket provided by the factory for that particular type of joint. Swapping gaskets is not allowed.

*Pre Approved Products:*

*Diamond C900 and C905 As Manufactured by Diamond Plastics Company*

Blue Brute and Big Brute As Manufactured by J-M Manufacturing Company, Inc.

## **2.5 Welded Steel Pipe**

Welded steel pipe shall conform to AWWA C200. Ends of sections of welded steel pipe shall be prepared for the type of joint set forth in the Contract Documents.

### **2.5.1 Interior Lining**

The Interior of welded steel pipe shall be protected from corrosion with factory applied cement mortar lining in accordance with AWWA C205, liquid epoxy conforming to AWWA C210 or fusion bonded epoxy conforming to AWWA C213.

### **2.5.2 Exterior Coating**

The exterior of welded steel pipe shall be protected from corrosion with hot-applied coal tar enamel and tape conforming to AWWA C203, or spiral wire reinforced cement mortar coating conforming to AWWA C205.

### **2.5.3 Joints**

For flexible coupled field joints, ends of pipe shall be plain. Welded beads on the outside of the pipe shall be trimmed down so that the weld metal does not project above the surface of the adjacent metal for a distance back from the ends of the pipe of 6 inches, or as otherwise specified in the project specifications. Bolted, sleeve-type couplings for plain-end pipe shall conform to AWWA C219.

For Lap-Welded field joints, at least one end of each section shall be belled to provide a tight-fitting socket, which will allow a lap when the joint is assembled of at least 1 inch with the adjacent plain end of the next section of pipe.

For rubber-gasketed joints, the spigot ends shall have a groove to accommodate a round rubber gasket of the proper diameter and cross-section. The bell end shall be so shaped that, upon the insertion of a spigot into the bell, the gasket becomes deformed and completely fills the groove and, as the joint is closed, the gasket becomes completely enclosed by steel. The gasket shall be furnished with the pipe and shall provide the sole means of making the joint watertight.

For flanged joints, a steel slip-on weld flange of the specified size shall be welded to the end of the bare pipe before any coatings are applied.

## **3 Fittings**

### **3.1 Bolted Sleeve Couplings (Flex Couplings)**

Bolted sleeve couplings (flex couplings) shall conform to AWWA C219 and these specifications. Flex couplings shall consist of a carbon steel or stainless steel sleeve conforming to the material requirements of AWWA C200 or C220, respectively. The sealing mechanism at each end of the sleeve shall consist of a rubber gasket certified by an ANSI accredited organization to be in compliance with NSF/ANSI 61 and compressed by a stainless or carbon steel compression ring. The Compression ring shall be tensioned by a single nut and bolt which acts perpendicular to the pipe centerline. Sleeves larger than 12 inches may use two nuts and bolts to provide tension. All fasteners and washers shall consist of stainless steel.

Flex couplings shall provide for a minimum of 8 degrees of pipe deflection. Flex couplings shall have a working pressure of not less than 200 psi.

#### **3.1.1 Interior/Exterior Coating**

All non-stainless steel components of flex couplings shall be protected from corrosion by a fusion-bonded epoxy coating conforming to AWWA C213, or another quality factory-applied coating approved by the Engineer.

*Pre Approved Products:*

Hymax Couplings as manufactured by Total Piping Solutions, Inc.

### **3.2 Brass Fittings**

Brass fittings shall conform to AWWA C800 and these specifications. Brass fittings shall consist of brass alloy having a lead content not more than 0.25 percent by weight. Brass shall meet the composition, chemical and mechanical requirements of C89520 or C89833 alloys as specified by the Copper Development Association, Inc.

Brass fittings shall be suitable for use at pressures not less than 150 psi.

#### **3.2.1 Joints**

Joints between brass fittings and copper pipe shall be made with iron pipe thread to CTS grip joint adapters. Joints between brass fittings and brass pipe shall be iron pipe threaded. Soldered joints or flare fittings are prohibited.

*Pre Approved Products:*

*Low-lead brass fittings as manufactured by James Jones Company marked "EBII" or "FD"*

No-lead brass fittings as manufactured by The Ford Meter Box Company, marked "NL"

### **3.3 Ductile Iron Fittings**

Ductile iron fittings shall conform to AWWA C110 or C153, in material, body thickness and radii of curvature with the exception of laying lengths.

### **3.3.1 Interior Lining**

Ductile iron fittings shall be lined with a bituminous seal-coated cement mortar lining conforming to AWWA C104.

### **3.3.2 Exterior Coating**

Ductile iron fittings shall be coated with an asphaltic coating conforming to AWWA C110, or with fusion bonded epoxy conforming to AWWA C116.

### **3.3.3 Joints**

Joints in DI fittings shall be push-on, mechanical or flanged rubber gasket joints conforming to AWWA C111. Rubber gaskets and gasket lubricant shall be certified by an ANSI accredited organization to be in compliance with NSF/ANSI 61 and shall not impart taste or odor to water.

Push-on rubber gasket joints shall use the gasket provided by the factory for that particular joint. Swapping gaskets is not allowed.

DI fitting joints shall include joint restraints conforming to the applicable sections of these specifications.

## **3.4 Welded Steel Fittings**

Dimensions of welded steel fittings shall conform to AWWA C208.

Materials, linings, coatings and joint types of welded steel fittings shall be the same types as the welded steel pipe to which the fitting is to be attached and shall conform to the applicable sections of these specifications.

## **4 Joint Restraints**

### **4.1 Joint Restraints for DI Push-On Joints**

Joint restraints for DI pipe push-on joints shall consist of bell restraint harnesses and/or rubber gaskets with embedded locking elements. Joint restraints shall be capable of restraining the thrust force created at two times the rated working pressure of the pipe or fitting to which they are attached.

Bell restraint harnesses for DI push-on joints shall consist of two split-ring harnesses manufactured from ductile iron conforming to ASTM A536. One split-ring harness shall bear upon the back of the pipe bell. The other split-ring harness shall grip the spigot end of the adjacent pipe with individual bolt-tightened wedges. The wedges shall have a Brinell hardness number not less than 370. Wedge-tightening bolts shall be provided from the factory with heads which break away when proper torque is reached. The split-ring harnesses shall be connected and tensioned by threaded rods and nuts. The split-ring harnesses shall be protected against corrosion with a high quality factory-applied coating. Nuts, bolts, and threaded rods shall be either stainless steel or protected against corrosion with a field-applied bitumastic coating approved by the Engineer.

Locking gaskets shall consist of a rubber gasket conforming to AWWA C111 embedded with stainless steel toothed gripping elements.

*Pre Approved Products:*

*Series 1700 or 1100HD Bell Restraint Harness as manufactured by EBAA Iron, Inc.*

Field Lok 350 gaskets as manufactured by U.S. Pipe

### **4.2 Joint Restraints for Mechanical Joints with DI Pipe**

Joint restraints for DI Mechanical Joints with DI pipe shall be capable of restraining the thrust force created at two times the rated working pressure of the pipe or fitting to which they are attached.

Joint restraints for mechanical joints shall consist of a ductile iron mechanical joint gland conforming to ASTM A536. The gland shall conform to AWWA C111 and shall grip the spigot end of the pipe with individual bolt-tightened wedges. The wedges shall have a Brinell hardness number not less than 370. Wedge-tightening bolts shall be factory provided with heads which break away when proper torque is reached. The DI gland shall be protected against corrosion with a high quality factory applied coating. Nuts and bolts shall be either stainless steel or protected against corrosion with a field-applied bitumastic coating approved by the Engineer.

*Pre Approved Products:*

Megalug Series 1100 or 1100SD as manufactured by EBAA Iron, Inc.

### **4.3 Joint Restraints for Mechanical Joints with PVC Pipe**

Joint restraints for DI Mechanical joints with PVC pipe shall meet or exceed the requirements of ASTM F1674.

The gland shall consist of ductile iron conforming to ASTM A536 and shall conform to AWWA C111. Restraint shall be provided by individual bolt-tightened wedges which grip the spigot end of the adjacent pipe. Wedge-tightening bolts shall be factory provided with heads which break away when proper torque is reached. The spacing and number of bolt tightened wedges shall be designed by the manufacturer specifically for type of pipe they will grip. The DI gland shall be protected against corrosion with a high

quality factory applied coating. Nuts and bolts shall be either stainless steel or protected against corrosion with a field-applied bitumastic coating approved by the Engineer.

*Pre Approved Products:*

Megalug Series 1100 or 1100SD as manufactured by EBAA Iron, Inc.

#### **4.4 Joint Restraints for PVC Push-On Joints**

Joint restraints for PVC pipe push-on joints shall meet or exceed the requirements of ASTM F1674.

Joint restraints for PVC pipe push-on joints shall consist of bell restraint harnesses. Bell restraint harnesses for PVC pipe shall consist of two serrated split-ring, harnesses manufactured from ductile iron conforming to ASTM A536. One serrated split-ring harness shall grip the bell end of the pipe behind the bell. The other serrated split-ring harness shall grip the spigot end of the adjacent pipe. The serrated split-ring harnesses shall be tightened onto the pipe barrel with a bolt on either side. The two pipe gripping harnesses shall be connected by threaded rods and nuts. The ductile iron serrated split-ring harnesses shall be protected against corrosion with a quality factory-applied coating. Nuts, bolts and threaded rods shall be either stainless steel or protected against corrosion with a field applied bitumastic coating approved by the Engineer.

*Pre Approved Products:*

*Series 1500 Bell Restraint Harness as manufactured by EBAA Iron, Inc.*



## **5 Valves**

### **5.1 Air Valves**

Air Valves shall conform to AWWA C512. The interior linkage parts and fasteners shall consist of brass or stainless steel. Floats shall be plastic or stainless steel. The interior surfaces of air valves shall be coated in conformance with AWWA C550. Air valves shall be watertight.

#### **5.1.1 Vacuum Relief Valve**

Air/vacuum valves shall permit large volumes of air to exit or enter the pipe while the pipe is not under pressure.

*Pre Approved Products:*

*S-1500 series Vacuum Relief Valve as manufactured by Apco Williamette Valve and Primer Corporation.*

#### **5.1.2 Air Release Valves**

Air release valves shall permit release of small amounts of entrained air from the pipe, while the pipe is operating under pressure.

*Pre Approved Products:*

*S-50 series or S-200A series Air Release Valve as manufactured by Apco Williamette Valve and Primer Corporation.*

#### **5.1.3 Combination Air Valves**

Combination air valves shall perform the functions of both air/vacuum valves and air release valves. Valves smaller than 4" shall be self-contained in one unit, not a combination of two valves.

*Pre Approved Products:*

*S-140c series As manufactured by Apco Williamette Valve and Primer Corporation.*

### **5.2 Backflow Prevention Assemblies**

Only assemblies that appear on the list of approved devices maintained by SCWD are permitted for use. The Contractor shall verify that the device to be installed appears on the most recent SCWD list of approved devices.

Assemblies shall be shipped from the manufacturers in the fully assembled configuration. This includes bypass arrangements and shutoff valves. Assemblies received for installation not completely assembled are not approved. Field conversions of double check assemblies to a detector assembly, or vice versa, are not permitted.

### **5.3 Brass Valves**

Brass valves shall conform to AWWA C800 and these specifications. Brass valves shall be certified by an ANSI accredited organization to be in compliance with NSF/ANSI 61. Brass valves shall consist of brass alloy having a lead content not more than 0.25 percent by weight. Brass shall meet the

composition, chemical and mechanical requirements of C89520 or C89833 alloys as specified by the Copper Development Association, Inc. Brass valves shall bear a mark from the manufacturer indicating that the fitting is composed of a no-lead or low-lead alloy.

Brass valves shall be suitable for use at pressures not less than 150 psi.

### **5.3.1 2 Inch Fire Service Gate Valves**

2-inch gate valves shall be of all bronze construction (including valve stem and handle), female iron pipe thread by female iron pipe thread , wheel handle valves.

*Pre Approved Products:*

*J-372 as manufactured by James Jones Company*

### **5.3.2 Angle Meter Stops**

Angle meter stops shall be equipped with heads which allow the angle meter stop to be locked in the off position.

*Pre Approved Products:*

*Low-lead angle meter stops as manufactured by James Jones Company marked "EBII" or "FD"*

*No-lead angle meter stops as manufactured by The Ford Meter Box Company, marked "NL"*

### **5.3.3 Corporation Stops**

Corporation stops shall be male iron pipe thread by male iron pipe thread. Connection to copper service line shall be made with an iron pipe thread to CTS grip joint adapter

*Pre Approved Products:*

*Low-lead brass corporation stops as manufactured by James Jones Company marked "EBII" or "FD"*

*No-lead brass corporation stops as manufactured by The Ford Meter Box Company, marked "NL"*

## **5.4 Check Valves**

### **5.4.1 Meter Check Valve**

Meter check valves for use with 5/8-inch bypass meters shall consist of low-lead brass, shall be female iron pipe threaded on both ends, and shall be suitable for use at pressures not less than 150 psi.

*Pre Approved Products: HS11-333NL as manufactured by The Ford Meter Box Company, marked "NL"*

### **5.4.2 Backflow Devices**

See "Backflow Prevention Assemblies"

## **5.5 Fire Hydrants**

Fire hydrants shall include a hydrant head, hydrant bury and break-away features conforming to AWWA C503 and these specifications.

### **5.5.1 Hydrant Head**

Hydrant heads shall be all bronze, 6-inch diameter, wet-barrel units. Hydrant heads shall be of the “steamer” variety, having two 2 ½-inch outlets and one 4 ½-inch outlet.

Hydrant outlets shall have National Standard hose threads. Hydrant outlet valves shall be operable by a pentagon shaped nut. Outlets shall be capped. Caps shall consist of either bronze or plastic and shall contain a rubber gasket. Hydrant caps shall not have chains attached. All hydrants and caps shall be painted with “post international yellow” enamel.

*Pre Approved Products:*

*2060 as manufactured by the Clow Valve Company.*

*J-3760 as manufactured by James Jones Company.*

### **5.5.2 Hydrant Bury**

The hydrant bury shall consist of ductile iron. The hydrant bury shall be sized so that the face of the flange is 2-4 inches above finished grade. The buried end of the hydrant bury shall be a mechanical joint conforming to AWWA C111. The interior and exterior of the hydrant bury shall be coated with fusion bonded epoxy which conforms to AWWA C116 and is certified by an ANSI accredited organization to be in compliance with NSF/ANSI 61.

*Pre Approved Products:*

*Ductile Iron Hydrant Bury as manufactured by the Clow Valve Company*

### **5.5.3 Break Away Features**

The hydrant head shall be attached to the bury with a break away spool and stainless steel bolts and nuts.

One set of flange bolts shall be hollow break away bolts, having a combined ultimate strength less than the yield strength of the hydrant head or bury.

The break away spool shall consist of ductile iron and shall have an ultimate strength less than the yield strength of the hydrant head or bury. The interior of the break away spool shall be coated with fusion bonded epoxy coating which conforms to AWWA C116 and is certified by an ANSI accredited organization to be in compliance with NSF/ANSI 61. The exterior shall be primed and painted with “post international yellow” enamel to match the hydrant.

## **5.6 Main Line Valves**

Underground main line valves and service valves 4 inches and larger in diameter shall be iron body, resilient seated gate valves conforming to AWWA C509 or C515.

The wedge or “gate” of the valve shall consist of bronze or ductile iron completely encapsulated with sealing rubber. The sealing rubber shall be permanently bonded to the wedge. The waterway of the valve

shall have a diameter equal to the nominal diameter of the valve and be smooth, unobstructed, and free of surface irregularities.

The stem stuffing box shall be serviceable with valve fully open and subjected to full rated working pressure.

Valves shall be equipped with a 2-inch square ductile iron operating nut, and the valve shall open when turned to the left (counter-clockwise). Valve stems shall not rise out of the body when the valve is operated. The operating nut shall be securely keyed into the stem at the factory, and shall be capable of withstanding repeated operation to the satisfaction of the Engineer.

All bolts on the valve shall consist of stainless steel. Valves shall be equipped with o-ring seals at all pressure retaining joints.

### **5.6.1 Interior/Exterior Coating**

All iron parts except the operating nut shall be coated with fusion bonded epoxy, conforming to AWWA C550 and certified by an ANSI accredited organization to be in compliance with NSF/ANSI 61.

### **5.6.2 Joints**

Valve ends shall be either flanged or restrained mechanical joints conforming to AWWA C111, and pertinent sections of these specifications.

*Pre Approved Products:*

*Resilient Seated Gate Valve as manufactured by the Clow Valve Company*

## **6 Appurtances**

### **6.1 Boxes and Lids**

#### **6.1.1 Non Traffic Rated Meter Boxes**

Meter boxes which will not be subjected to vehicle loading shall consist of precast reinforced concrete. Lids shall be solid reinforced concrete. "reading lids" are not allowed. Lids shall be imprinted with the applicable markings at the factory. Meter box and lid dimensions shall be identical to those of the pre approved products listed below.

*Pre Approved Products:*

*B16BOX (box) and B16D (lid) as manufactured by Christy Concrete Products, Inc.*

*B36BOX (box) and B36D (lid) as manufactured by Christy Concrete Products, Inc.*

#### **6.1.2 Traffic Rated Meter Boxes**

Meter boxes which may be subjected to vehicle loads shall consist of precast reinforced concrete boxes with steel rims. Traffic rated meter boxes shall be capable of withstanding AASHTO H20 wheel loading. Box dimensions shall be identical to those of the pre approved products listed below. Lids shall consist of a single continuous piece of steel tread plate, with reinforcements on the underside. "Reading lids" are not allowed. Lids shall be bolted to the box with stainless steel bolts. Lids shall be welded with markings per the applicable SCWD Detail.

*Pre Approved Products:*

*B1017BOX (box) and B1017-61JH (lid) as manufactured by Christy Concrete Products, Inc.*

*B1730BOX (box) and B1730-51JH (lid) as manufactured by Christy Concrete Products, Inc.*

#### **6.1.3 Valve Boxes**

Valve boxes shall be precast reinforced concrete, with cast iron rims. Valve boxes shall be capable of withstanding H/20 vehicle loading. Valve box lids shall be cast iron, and shall be marked in accordance with Detail 12. Valve box lids shall be properly fitting and shall not rattle when driven over by a vehicle.

Valve box and lid dimensions shall be identical to those of the pre approved products listed below.

*Pre Approved Products:*

*G05BOX (box) and G05C (lid) as manufactured by Christy Concrete Products, Inc.*

### **6.2 Aboveground Enclosures**

#### **6.2.1 Air Valve Enclosures**

Enclosures for aboveground air valve installations shall be cylindrical, and consist of steel solid sheet metal no thinner than 16-gauge. The size of the enclosure shall be as indicated by the Contract Documents, or approved in advance by the Engineer. Enclosures shall be protected from corrosion by a high quality factory applied coating, and shall be repainted with "hunter green" enamel. If

required by the Engineer, the enclosure shall consist of stainless steel. Enclosures shall provide for an SCWD pad lock in a manner acceptable to the Engineer.

*Pre Approved Products:*

*Steel Air Valve Enclosure as manufactured by Pipeline Products, Inc.*

### **6.2.2 Aboveground Meter Enclosures**

Enclosures for aboveground meter installations shall consist of solid steel sheet metal. Enclosures shall be protected from corrosion by a high quality factory applied coating approved by the Engineer, but may be repainted by the customer or property owner. For larger installations, the Engineer may approve the use of expanded sheet metal. If required by the Engineer, the enclosure shall consist of stainless steel. Enclosures shall provide for both a water-customer-supplied padlock and an SCWD padlock to be attached and operated without interfering with the operation of the other, in a manner acceptable to the Engineer.

*Pre Approved Products:*

*E1A Backflow Enclosure as manufactured by Placer Waterworks, Inc.*

## **6.3 Radio Read Conduit**

Radio read conduit shall consist of flexible corrugated non-metallic direct bury conduit. Size of conduit shall be as specified on Detail 2.

## **6.4 Repair Clamps**

Repair clamps shall consist of a stainless steel band tensioned with stainless steel nuts and bolts. A water tight seal shall be provided by a waffled mat-type gasket certified by an ANSI accredited organization to be in compliance with NSF/ANSI 61.

*Pre Approved Products:*

*EZ-MAX Repair Clamp as manufactured by Total Piping Solutions, Inc.*

SS1 – Stainless Seal as manufactured by Romac Industries, Inc.

## **6.5 Tapping Saddles and Tapping Sleeves**

Tapping saddles and sleeves shall conform to AWWA C800 and these specifications.

The subsections below are arranged in hierarchal order. Any tapping saddle or sleeve specified for a particular water main type may also be used on the water main types listed in the sections below it.

### **6.5.1 Tapping Sleeves for Steel Water Mains**

Tapping sleeves used to tap steel water mains shall consist entirely of stainless steel, and utilize all stainless steel hardware. Tapping sleeves for services smaller than 4 inches shall have female iron pipe threads. Sleeves for services larger than 4 inches shall be flanged in accordance with AWWA C111. A water tight seal against the main shall be provided by a waffled mat-type gasket certified by an ANSI accredited organization to be in compliance with NSF/ANSI 61.

*Pre Approved Products:*

*SST, SSTIII Stainless Steel Tapping Sleeve as manufactured by Romac Industries, Inc.*

*EZ-Tap Plus as manufactured by Total Piping Solutions, Inc.*

*FAST Tapping Sleeve as manufactured by The Ford Meter Box Company, Inc.*

### **6.5.2 Tapping Saddles for PVC Water Mains**

Tapping saddles used to tap PVC water mains shall consist entirely of brass or bronze, and utilize all brass or bronze hardware. Tapping saddles shall have female iron pipe threads of the appropriate size. Tapping saddles shall be equipped with a single, wide strap which fully encircles the main. The strap shall not be hinged to the tapping saddle, but shall attach with bolts on both sides. Watertight seal against the main shall be provided by a rubber gasket certified by an ANSI accredited organization to be in compliance with NSF/ANSI 61.

*Pre Approved Products:*

*S91, Design B as manufactured by The Ford Meter Box Company, Inc.*

### **6.5.3 Tapping Saddles for A-C and CI Water Mains**

Tapping saddles used to tap A-C and CI water mains shall consist entirely of brass or bronze, and utilize all brass or bronze hardware. Tapping saddles shall have female iron pipe threads of the appropriate size. Tapping saddles shall have dual straps which connect to the saddle on both sides with bolts, and fully encircle the main. Watertight seal against the main shall be provided by a rubber gasket certified by an ANSI accredited organization to be in compliance with NSF/ANSI 61.

*Pre Approved Products:*

*202B as manufactured by The Ford Meter Box Company, Inc.*

### **6.5.4 Tapping Saddles for DI Mains**

Tapping saddles used to tap DI mains shall consist entirely of brass or bronze, and utilize all brass or bronze hardware. Tapping saddles shall have female iron pipe threads of the appropriate size. Straps shall not be hinged to the tapping saddle, but shall attach to the saddle on both sides with bolts, and fully encircle the main. Watertight seal against the main shall be provided by a rubber gasket certified by an ANSI accredited organization to be in compliance with NSF/ANSI 61.

*Pre Approved Products:*

*101B as manufactured by The Ford Meter Box Company, Inc.*

## **6.6 Wrapping Tape**

Pipe wrapping tape shall be 2" wide 10-mil polyvinyl tape.

*Pre Approved Products:*

*Polyvinyl pipe tape as manufactured by Calpico, Inc.*

## **6.7 Wood Blocking & Posts**

Wood shall be redwood or pressure treated fir.

## **7 Backfill & Pavement**

### **7.1 Backfill Material**

Backfill material shall conform to the requirements of the applicable public works agency. If that agency has no published or readily available standards, backfill material shall conform to the requirements listed in the following sections.

#### **7.1.1 Sand**

Sand shall be clean, free of clay, debris, and organic or deleterious material. Sand shall conform to the following grading requirements.

100% passing the No. 4 sieve.

80-95% passing the No. 8 sieve.

Not more than 5% passing the No. 200 sieve.

#### **7.1.2 Aggregate Base**

Aggregate base shall be clean, free of clay, debris, organic and deleterious material.

Aggregate base shall be Class 2 Aggregate Base, ¾" maximum conforming to Section 26 of the CalTrans Standard Specifications. Aggregate base shall conform to the following grading requirements.

100% passing the 1" sieve.

90-100% passing the ¾" sieve.

35-60% passing the No. 4 sieve.

10-30% passing the No. 30 sieve.

2-9% passing the No. 200 sieve.

#### **7.1.3 CLSM**

Controlled low strength material (CLSM) shall be 1-sack cement sand slurry with a slump of 7 to 9 inches and a 28 day unconfined compressive strength of 50 to 150 psi. CLSM shall be mixed in a transit mixer. Certification tickets shall be submitted at the request of the Engineer.

### **7.2 Pavement**

Pavement shall conform to the requirements of the applicable public works agency. If that agency has no published or readily available standards, Pavement shall conform to the requirements listed in the following sections.

#### **7.2.1 Asphalt Concrete**

Asphaltic concrete shall be Type B, or better, conforming to Section 39 of the CalTrans Standard Specifications. Type A asphaltic concrete may be substituted for Type B if it is required by another



agency, design engineer or is delivered to site instead of Type B. Gradations shall be per the specifications of the appropriate public works agency.

### **7.2.2 Portland Cement Concrete**

All concrete shall be Portland cement concrete and shall be composed of Type II or Type V portland cement conforming to ASTM C150, fine and coarse aggregates, water and admixtures. Portland cement concrete shall be proportioned and mixed as required to produce a smooth, workable mixture. It shall have a minimum ultimate compressive strength of 3,000 psi as determined by ASTM C873. The maximum size of aggregate shall be that which passes a 1" mesh screen. Concrete shall not contain less than 6 sacks (565 lbs) of cement per cubic yard.

### **7.2.3 Concrete Reinforcement**

Reinforcing bars shall conform to ASTM A615. All bars shall be deformed.

Welded wire mesh reinforcement may be plain or deformed. Plain wire shall conform to ASTM A185. Deformed wire shall conform to ASTM A497.

## **8 Miscellaneous**

### **8.1 Disinfection Materials**

Chlorine (bleach) used for disinfection may be either liquid chlorine or sodium hypochlorite solution. Calcium hypochlorite shall not be used unless approved in advance by the Engineer. Chlorine shall be certified by an ANSI accredited organization to be in compliance with NSF/ANSI 60.

All materials used for disinfection of water mains such as jumper hoses and fittings shall be certified by an ANSI accredited organization to be in compliance with NSF/ANSI 61.

Chlorine neutralizing material shall consist of ascorbic acid.

### **8.2 Temporary Materials**

Materials used for temporary facilities shall consist of materials which will safely perform their intended purpose for the duration of their intended life. Temporary materials are subject to the approval of the Engineer. Temporary materials which will contact potable water shall be certified by an ANSI accredited organization to be in compliance with NSF/ANSI 61.

## **Section 3 Standard Details**

## INDEX

## ABBREVIATIONS

1	SERVICE CONNECTION
2	METER BOX INSTALLATION
3	1-INCH AND SMALLER MULTIPLE BRANCHED SERVICE INSTALLATION
4	COMBINATION 2-INCH FIRE AND DOMESTIC SERVICE INSTALLATION
5	2-INCH AND SMALLER SERVICE INSTALLATION
6	3-INCH OR 4-INCH SERVICE INSTALLATION
7	6-INCH AND LARGER SERVICE INSTALLATION
8	2-INCH AND SMALLER BACKFLOW PREVENTION ASSEMBLY INSTALLATION
9	4-INCH AND LARGER FIRE SERVICE INSTALLATION
10	FIRE HYDRANT INSTALLATION
11	GATE VALVE INSTALLATION
12	VALVE BOX LID MARKINGS
13	RESERVED
14	SERVICE LATERAL TRENCH
15	STANDARD WATER MAIN TRENCH
16	SUB-STANDARD WATER MAIN TRENCH
17	SYSTEM CONNECTION (TIE IN)
18	JOINT RESTRAINT INSTALLATION
19	THRUST BLOCK INSTALLATION
20	TRAFFIC BOLLARD INSTALLATION
21	SAMPLE STATION INSTALLATION
22	CHLORINATION TAP INSTALLATION
23	BLOW OFF INSTALLATION
24	AIR VALVE INSTALLATION
25	BELOW GRADE AIR VALVE INSTALLATION

AC	ASPHALT CONCRETE
A-C	ASBESTOS CEMENT
ACI	AMERICAN CONCRETE INSTITUTE
ARV	AIR RELEASE VALVE
AWWA	AMERICAN WATER WORKS ASSOCIATION
CI	CAST IRON
CL	CENTERLINE, CLASS
CLSM	CONTROLLED LOW STRENGTH MATERIAL
CTS	COPPER TUBE SIZE
DCDA	DOUBLE CHECK DETECTOR ASSEMBLY
DIA, Ø	DIAMETER
DI	DUCTILE IRON
DIP	DUCTILE IRON PIPE
(E)	EXISTING
EW	EACH WAY
FH	FIRE HYDRANT
FIP	FEMALE IRON PIPE
FLG	FLANGE
FS	FIRE SERVICE
FT	FEET
GA	GALVANIZED
HDPE	HIGH DENSITY POLYETHYLENE
IP	IRON PIPE
MAX	MAXIMUM
MIN	MINIMUM
MIP	MALE IRON PIPE
MJ	MECHANICAL JOINT
(N)	NEW
No.	NUMBER
OC	ON CENTER
OL	OPEN LEFT
PL	PROPERTY LINE
PRV	PRESSURE REDUCING VALVE
PSF	POUNDS PER SQUARE FOOT
PSI	POUNDS PER SQUARE INCH
PVC	POLYVINYL CHLORIDE
RP	REDUCED PRESSURE PRINCIPLE DETECTOR ASSEMBLY
SCWD	THE CITY OF SANTA CRUZ WATER DEPARTMENT
(TYP)	TYPICAL
USA	UNDERGROUND SERVICE ALERT
VERT	VERTICAL
WS	WELDED STEEL
ZV	ZONE VALVE

### NOTES

1. ON THESE DETAILS, "ENGINEER" SHALL MEAN THE DEPUTY DIRECTOR/ENGINEERING MANAGER OF THE CITY OF SANTA CRUZ WATER DEPARTMENT, ACTING PERSONALLY OR THROUGH HER AUTHORIZED REPRESENTATIVES.
2. ALL WORK SHALL CONFORM TO SECTION 1: TECHNICAL SPECIFICATIONS.
3. ALL MATERIALS SHALL CONFORM TO SECTION 2: MATERIAL SPECIFICATIONS.

	<p><b>WATER DEPARTMENT</b> CITY OF SANTA CRUZ, CALIFORNIA</p> <hr/> <p><b>STANDARD DETAILS</b></p>
--	--

POLYVINYL CHLORIDE  
WELDED STEEL  
ASBESTOS CEMENT  
CAST IRON  
DUCTILE IRON

STAINLESS STEEL SLEEVE MATERIAL SPECIFICATION 6.5.1	OK	OK	OK	OK	OK
SINGLE WIDE STRAP SADDLE MATERIAL SPECIFICATION 6.5.2	OK	OK	OK	OK	
DUAL STRAP SADDLE MATERIAL SPECIFICATION 6.5.3	OK	OK	OK		
SINGLE STRAP SADDLE MATERIAL SPECIFICATION 6.5.4	OK				

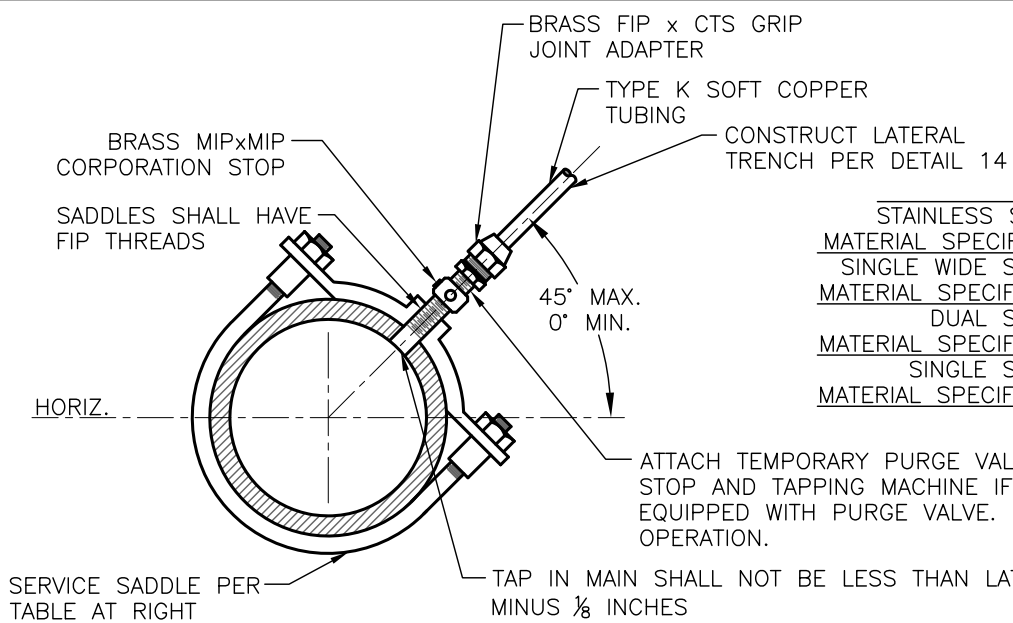

**SMALLER THAN 4"**

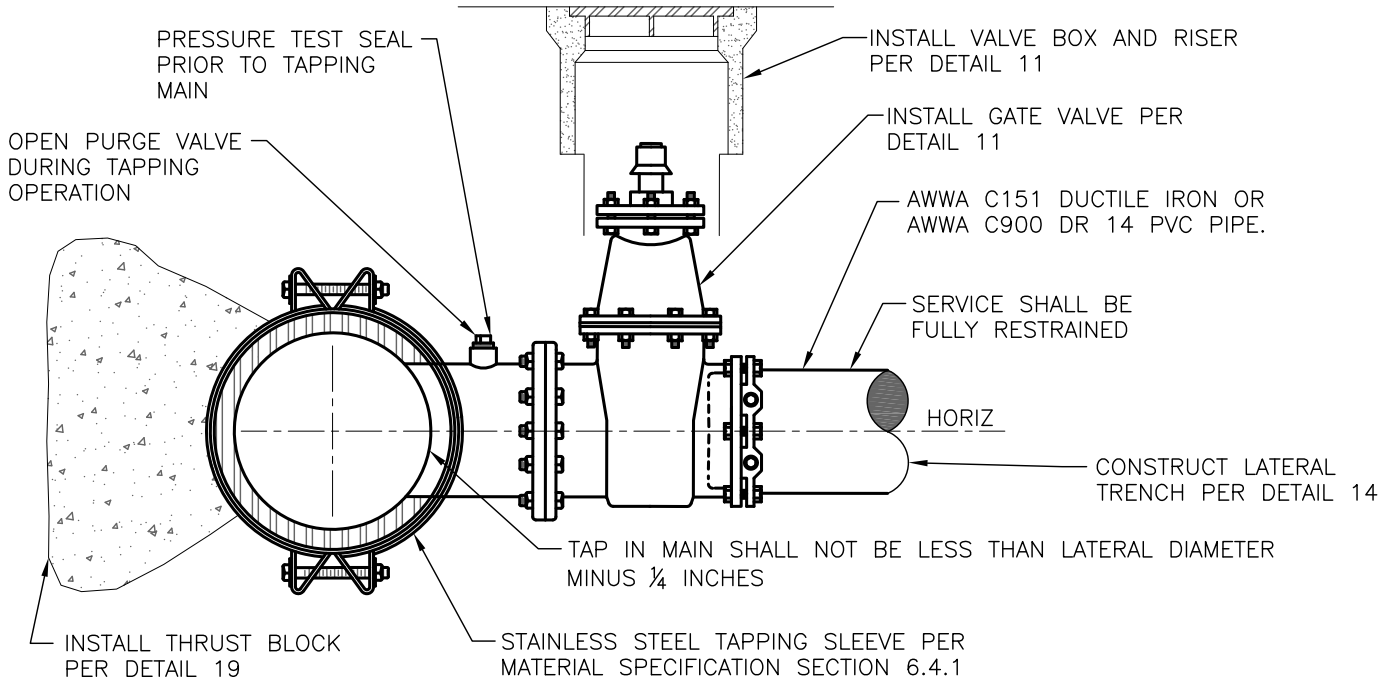

**4" AND LARGER**

**NOTES**

1. ALL HOT TAP CONNECTIONS SHALL BE MADE IN THE PRESENCE OF THE ENGINEER.
2. ALL HOT TAP CONNECTIONS SHALL BE AT LEAST 24" AWAY FROM ANY JOINT OR FITTING AND 18" AWAY FROM ANY OTHER TAP.
3. CONTRACTOR SHALL OPEN PURGE VALVE DURING TAPPING OPERATION.
4. SERVICE PIPING AND FITTING DIAMETERS SHALL MEET OR EXCEED THE SERVICE SIZE DESIGNATED BY THE ENGINEER.
5. TAPPING BIT SHALL BE OF THE HOLE-SAW OR SHELL TYPE.
6. COUPON OR "COOKIE" SHALL BE SUBMITTED TO THE ENGINEER UPON REQUEST.
7. IF COUPON IS LOST, CONTRACTOR SHALL FULLY OPEN SERVICE IN THE PRESENCE OF THE ENGINEER TO VERIFY FLOW.
8. CONTRACTOR SHALL COAT TAPPING SADDLE, ALL FASTENERS AND SERVICE LINE WITH BITUMASTIC AND/OR ENCASE IN POLYETHYLENE IF DIRECTED BY THE ENGINEER.
9. CONNECTIONS TO MAINS SMALLER THAN 4" SHALL BE SPECIFIED ON A CASE BY CASE BASIS.
10. SERVICE SHALL BE DISINFECTED IF REQUIRED BY THE ENGINEER.

**WATER DEPARTMENT**  
CITY OF SANTA CRUZ, CALIFORNIA

**DETAIL 1**

**SERVICE CONNECTION**

NOT TO SCALE

---

APPROVED *[Signature]* RCE 37391

DRAWING No. 2981 A REVISED DECEMBER 2009 C:\DOCUMENTS\LOCALS\1\Temp\AcPublish\3460\DEC2009.dwg

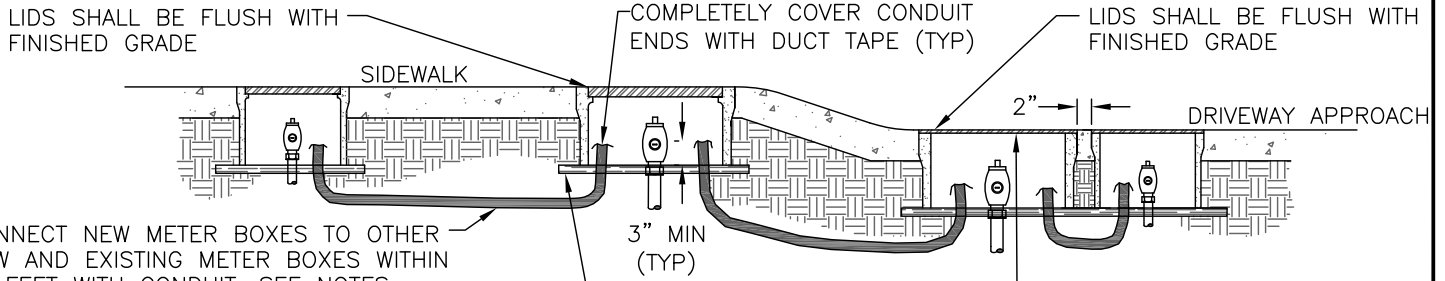

CONNECT NEW METER BOXES TO OTHER NEW AND EXISTING METER BOXES WITHIN 10 FEET WITH CONDUIT. SEE NOTES BELOW (TYP)

SAW CUT SIDEWALK AT NEAREST SAW CUT JOINTS. REMOVE AND REPLACE ENTIRE SIDEWALK SQUARE(S) IN KIND.

REDWOOD OR PRESSURE TREATED 2x4's UNDER SHORT OR LONG SIDES OF BOX (TYP). USE CONTINUOUS BOARDS UNDER ADJACENT BOXES.

FOR INSTALLATION IN DRIVEWAY APPROACH, USE TRAFFIC BOX. SEE TABLE BELOW.

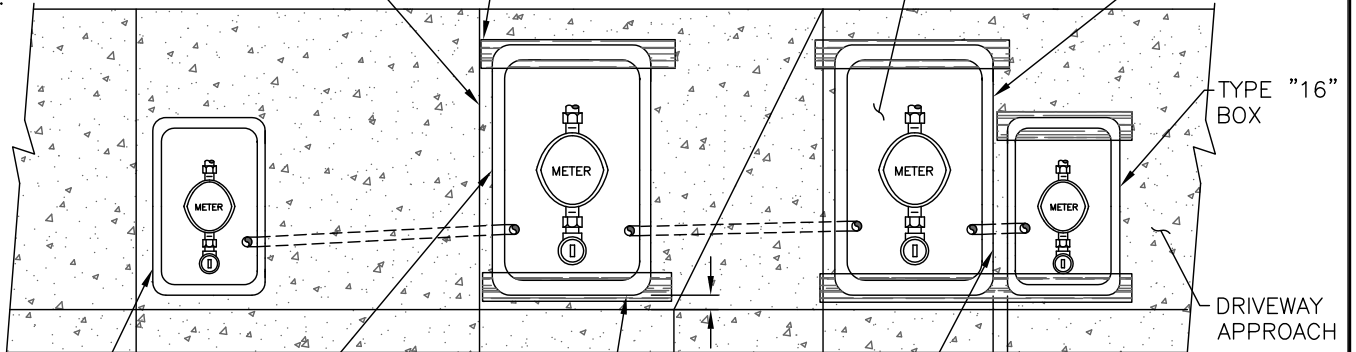

(E) METER BOX

EDGE OF METER BOX SHALL BE 2" BEHIND BACK OF CURB

ADJACENT METER BOXES SHALL BE 2" APART

FOR INSTALLATION BEHIND CURB USE NON-TRAFFIC BOX

### BEHIND-CURB INSTALLATION

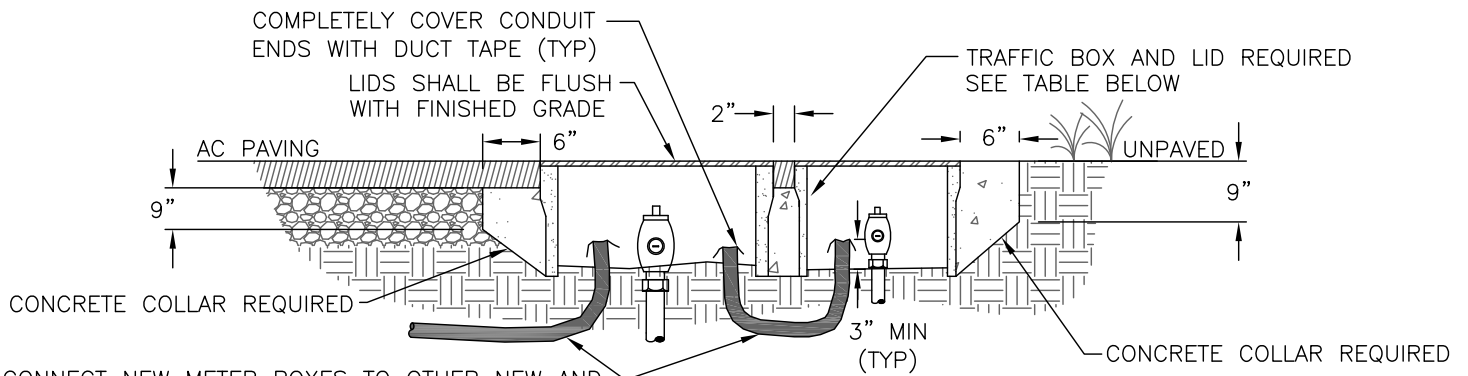

CONNECT NEW METER BOXES TO OTHER NEW AND EXISTING METER BOXES WITHIN 10 FEET WITH CONDUIT. SEE NOTES BELOW.

### INSTALLATION IN AREAS WITHOUT CURB

BOX TYPE	NON-TRAFFIC	TRAFFIC
TYPE "16"	CHRISTY B16 BOX W/ B16D LID OR EQUAL	CHRISTY B1017 BOX W/ B1017-JH LID OR EQUAL
TYPE "36"	CHRISTY N36 BOX W/ FL36D LID OR EQUAL	CHRISTY B1730 BOX W/ B1730-51JH LID OR EQUAL

#### NOTES

1. INSTALL CONDUIT AS SHOWN WHEREVER METER BOXES ARE WITHIN 10' OF OTHER NEW OR EXISTING BOXES.
2. CONDUIT SHALL BE NON-METALLIC, FLEXIBLE, CORRUGATED CONDUIT.
3. WHERE CONDUIT CONNECTS LESS THAN 12 BOXES, CONDUIT SHALL BE 1/2" MINIMUM DIAMETER.
4. WHERE CONDUIT CONNECTS 12 OR MORE BOXES, CONDUIT SHALL BE 1" MINIMUM DIAMETER.
5. ELECTRONICS AND WIRING WILL BE FURNISHED AND INSTALLED BY CITY FORCES.



WATER DEPARTMENT  
CITY OF SANTA CRUZ, CALIFORNIA

### DETAIL 2

METER BOX INSTALLATION

NOT TO SCALE

*Hudi R. Duckenbock*

APPROVED

RCE 37391

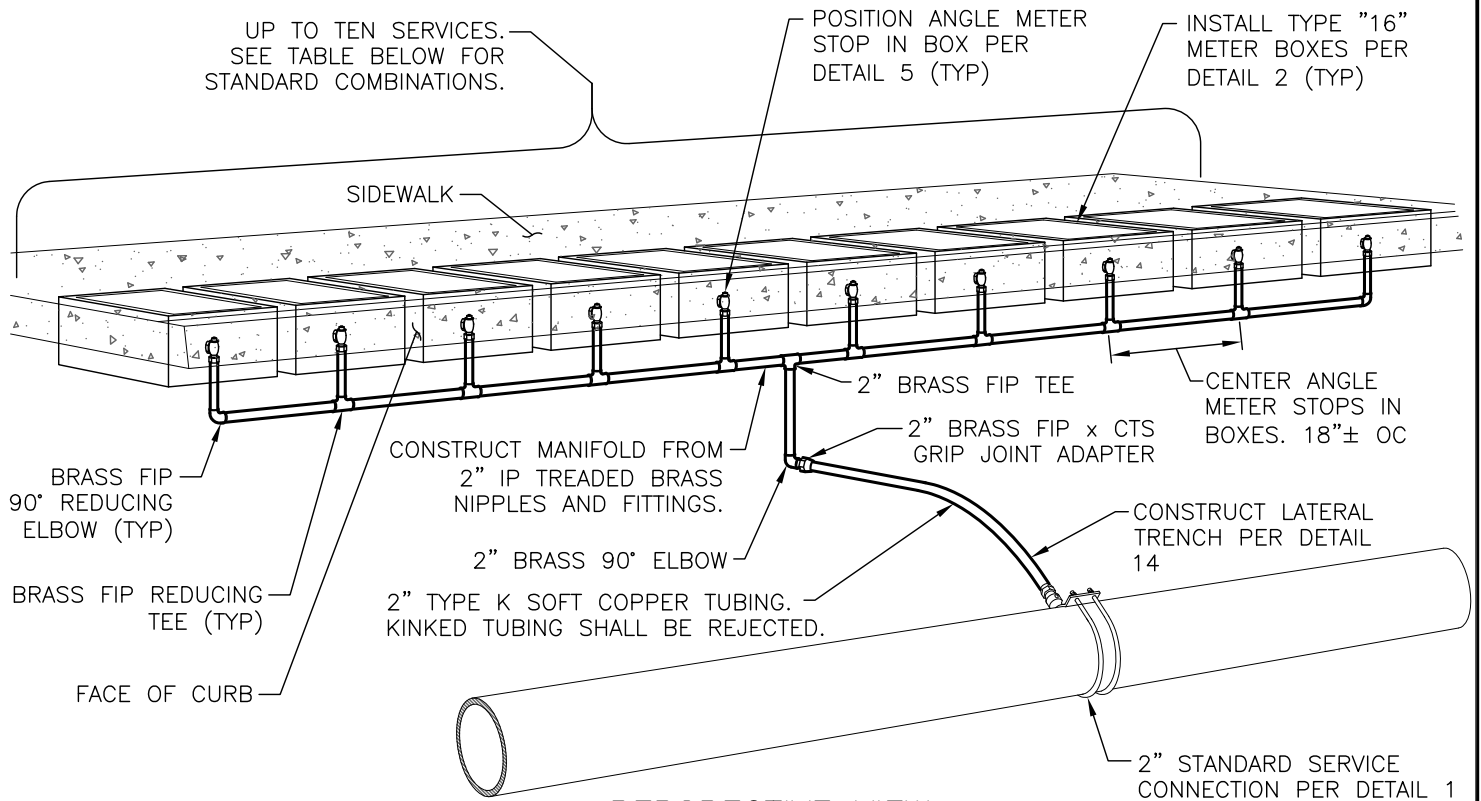

**PERSPECTIVE VIEW**

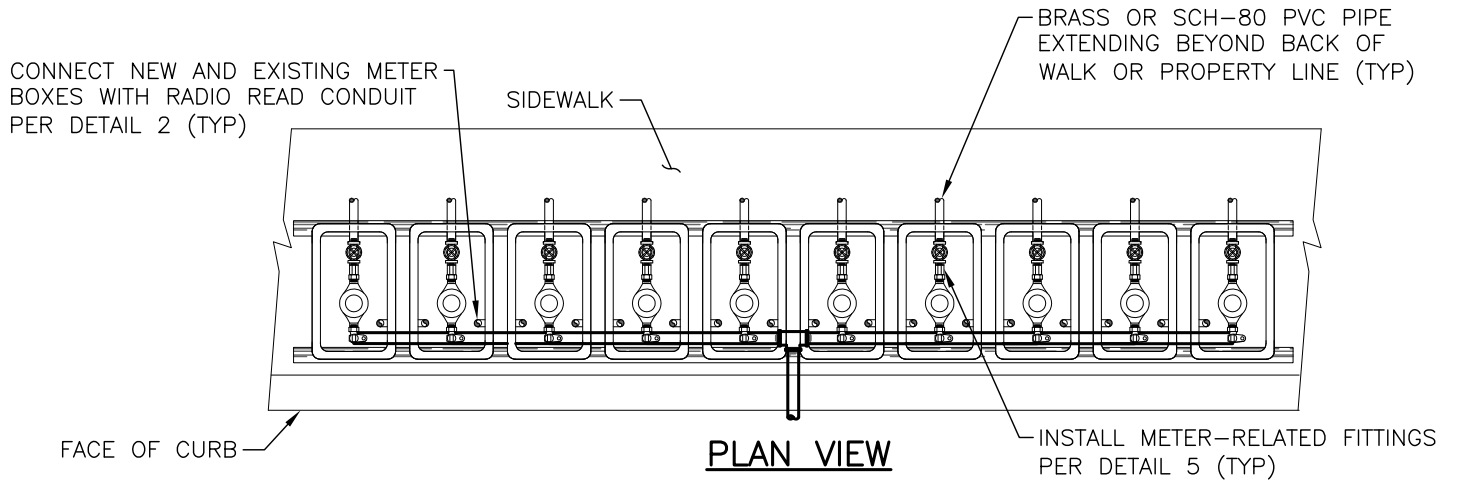

**PLAN VIEW**

NUMBER OF 1-INCH SERVICES	0	1	2	3	4
MAXIMUM NUMBER OF 3/4-INCH SERVICES	10	7	5	2	0

**NOTES**

- BRASS FITTINGS, VALVES AND PIPE SHALL CONSIST OF LOW-LEAD BRASS ALLOY AND SHALL HAVE A MINIMUM WORKING PRESSURE OF 150 PSI.
- FIRE SERVICES SHALL NOT BE COMBINED WITH OTHER SERVICES IN THIS MANNER.
- PERMISSION TO INSTALL SERVICES IN OTHER CONFIGURATIONS NOT SHOWN HERE MAY BE GRANTED BY THE ENGINEER. IN THIS CASE, THE DEVELOPER SHALL SUBMIT CALCULATIONS WHICH DEMONSTRATE TO THE SATISFACTION OF THE ENGINEER THAT THE RESIDUAL PRESSURE IS GREATER THAN A SINGLE SERVICE WHEN ALL SERVICES ARE FULLY OPEN.



**WATER DEPARTMENT**  
CITY OF SANTA CRUZ, CALIFORNIA

**DETAIL 3**  
**1-INCH AND SMALLER MULTIPLE BRANCHED SERVICE INSTALLATION**

NOT TO SCALE

APPROVED *[Signature]*

RCE 37391

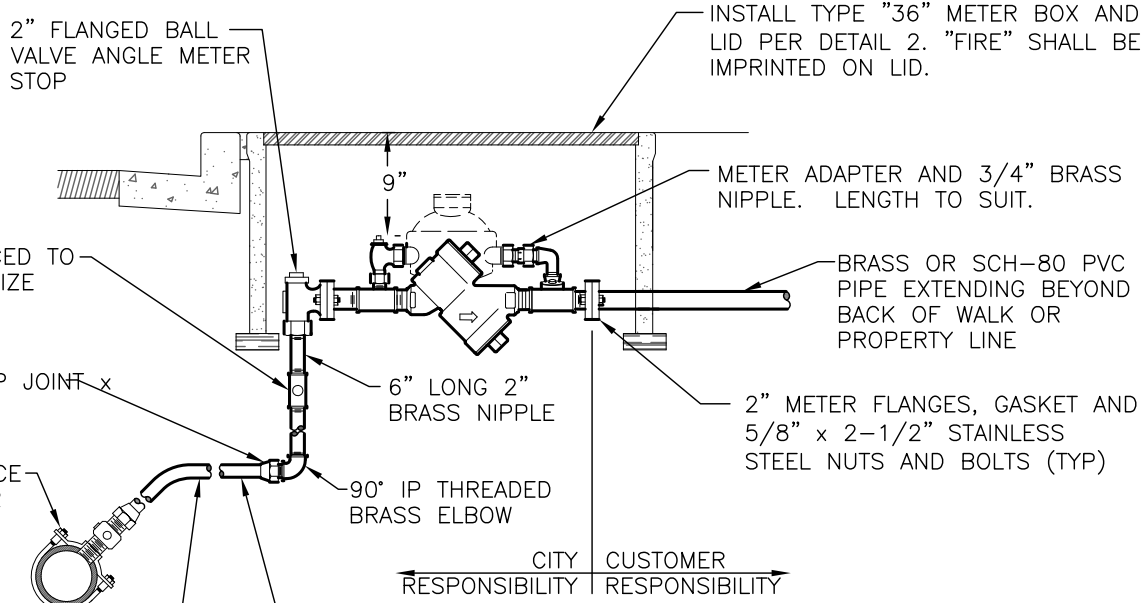

**ELEVATION VIEW**

2" TYPE K SOFT COPPER TUBING. KINKED TUBING SHALL BE REJECTED.  
 CONSTRUCT LATERAL TRENCH PER DETAIL 14  
 3/4" STREET ELBOW AND CORP STOP

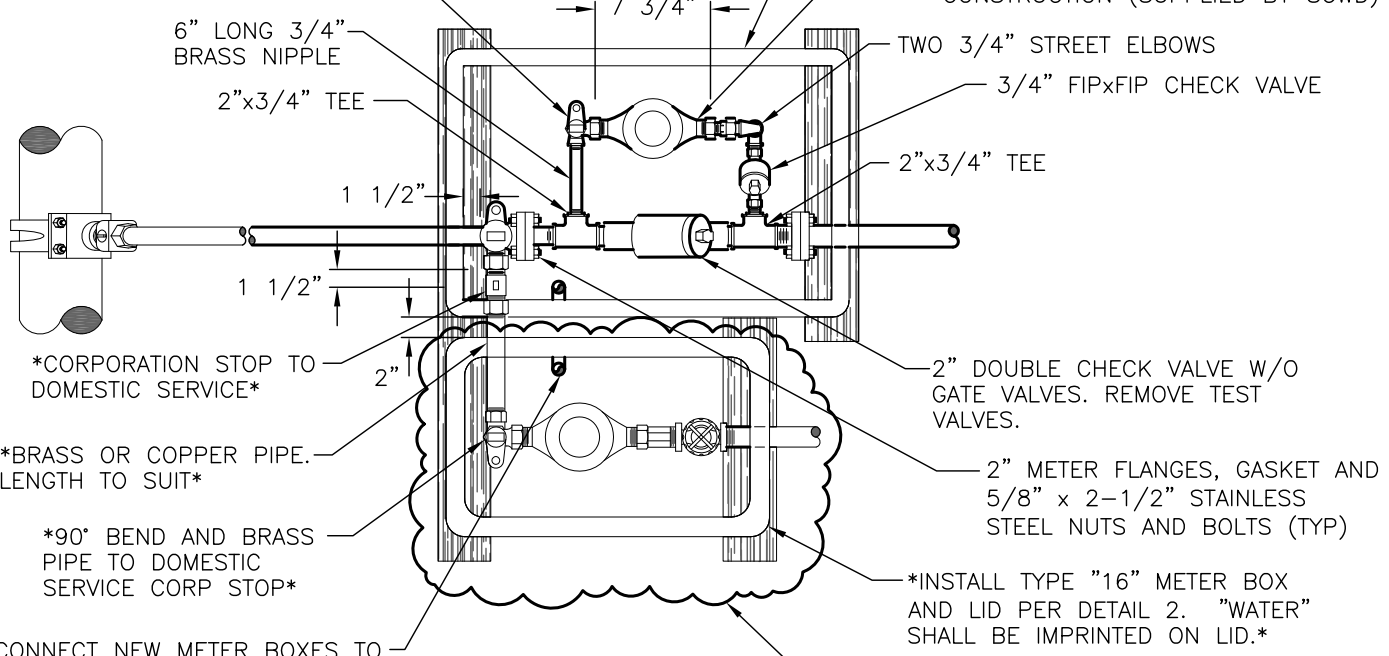

**PLAN VIEW**

\*CORPORATION STOP TO DOMESTIC SERVICE\*  
 \*BRASS OR COPPER PIPE. LENGTH TO SUIT\*  
 \*90° BEND AND BRASS PIPE TO DOMESTIC SERVICE CORP STOP\*  
 \*INSTALL TYPE "16" METER BOX AND LID PER DETAIL 2. "WATER" SHALL BE IMPRINTED ON LID.\*  
 \*INSTALL DOMESTIC SERVICE PER DETAIL 5\*

**NOTES**

- \* REQUIRED ONLY FOR COMBO SERVICE INSTALLATIONS.
- 1. BRASS FITTINGS, VALVES AND PIPE SHALL CONSIST OF LOW-LEAD BRASS ALLOY AND SHALL HAVE A MINIMUM WORKING PRESSURE OF 150 PSI.
- 2. FIRE SERVICE LINE SHALL BE TESTED FOR LEAKS PRIOR TO BACKFILLING.
- 3. CUSTOMER SIDE FIRE SERVICE PIPE TYPE AND CONNECTION SHALL MEET LOCAL FIRE AGENCY REQUIREMENTS.



**WATER DEPARTMENT**  
 CITY OF SANTA CRUZ, CALIFORNIA

**DETAIL 4**  
**COMBINATION 2-INCH FIRE AND DOMESTIC SERVICE INSTALLATION**

NOT TO SCALE

*Sancti*

APPROVED \_\_\_\_\_

RCE 37391

DRAWING No. 3274 A REVISED DECEMBER, 2009  
 C:\DOCUMENTS\LOCALS\1\Temp\AcPublish\_3460\DEC2009.dwg



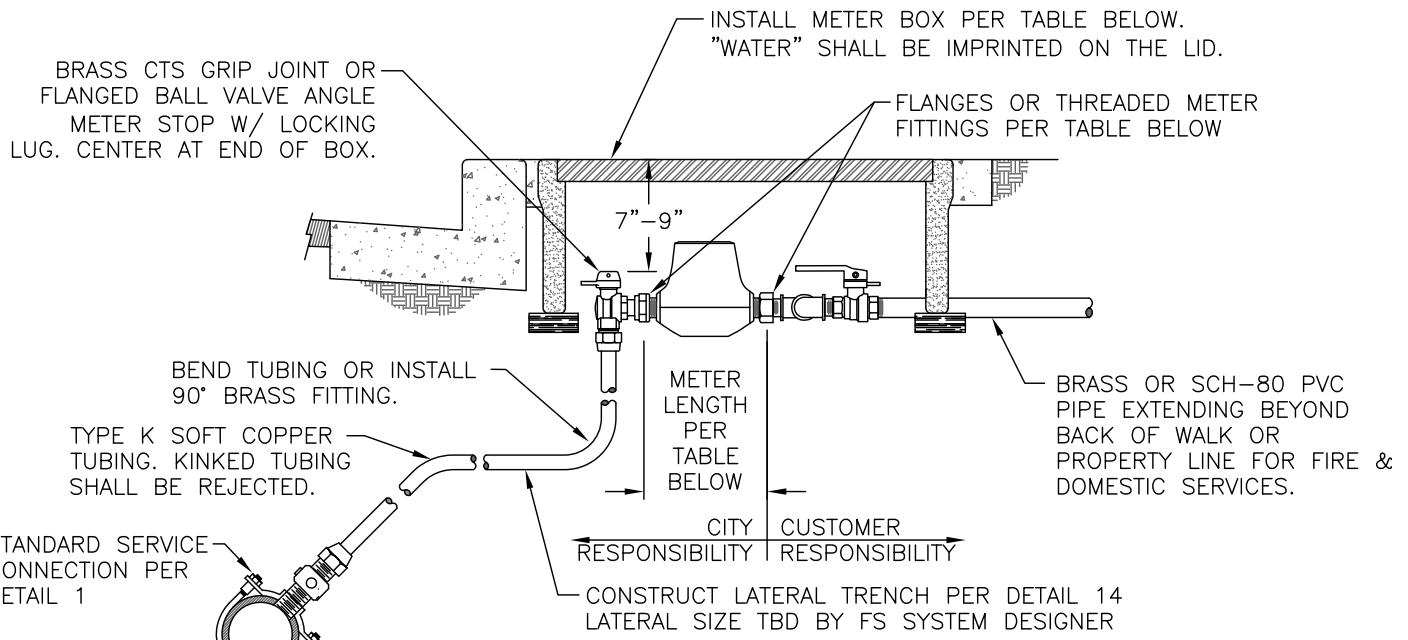

ELEVATION VIEW

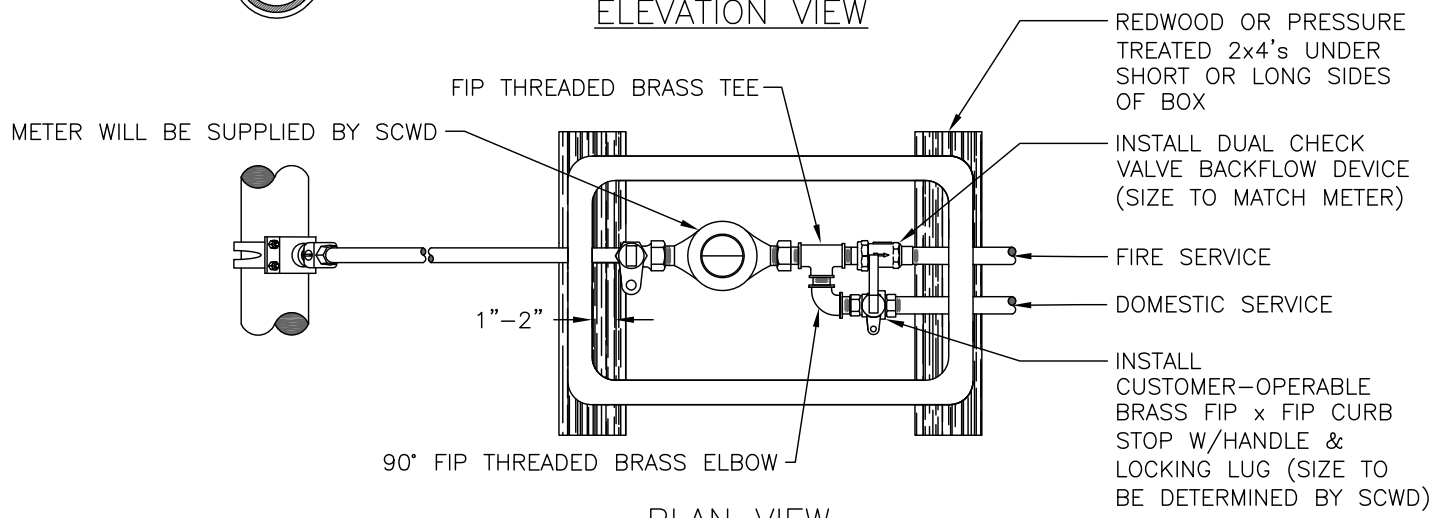

PLAN VIEW

METER SIZE AND TYPE DETERMINED BY FS SYSTEM DESIGNER	BOX TYPE	METER LENGTH
3/4" THREADED	"16"	7 3/4"
1" THREADED	"36"	11"
1 1/2" FLANGED	"36"	13"

BOX TYPE	NON-TRAFFIC	TRAFFIC
TYPE "16"	CHRISTY B16 BOX W/ N16R LID OR EQUAL	CHRISTY B1324 BOX W/ B1324-51JH LID OR EQUAL
TYPE "36"	CHRISTY N36 BOX W/ FL36D LID OR EQUAL	CHRISTY B1730 BOX W/ B1730-51JH LID OR EQUAL

NOTES

- BRASS FITTINGS, VALVES AND PIPE SHALL CONSIST OF LOW-LEAD BRASS ALLOY AND SHALL HAVE A MINIMUM WORKING PRESSURE OF 150 PSI.
- FIRE SERVICE LINE SHALL BE TESTED FOR LEAKS PRIOR TO BACKFILLING.
- CUSTOMER SIDE FIRE SERVICE PIPE TYPE AND CONNECTION SHALL MEET LOCAL FIRE AGENCY REQUIREMENTS.



WATER DEPARTMENT  
CITY OF SANTA CRUZ, CALIFORNIA

**DETAIL 4A**

DOMESTIC BY FIRE COMBINATION SERVICE INSTALLATION

NOT TO SCALE

---

*Hudi R. Luckenbach*

APPROVED RCE 37391

DRAWING No. 3274 A P:\WTE\Standard Specifications & Details\Water Standard Details\2013\_Revision\2013.dwg

BRASS CTS GRIP JOINT ANGLE  
METER STOP W/ LOCKING LUG.  
CENTER AT END OF BOX.

INSTALL METER BOX PER DETAIL 2. BOX TYPE  
PER TABLE BELOW. "WATER" SHALL BE  
IMPRINTED ON THE LID.

FLANGES OR THREADED METER  
FITTINGS PER TABLE BELOW

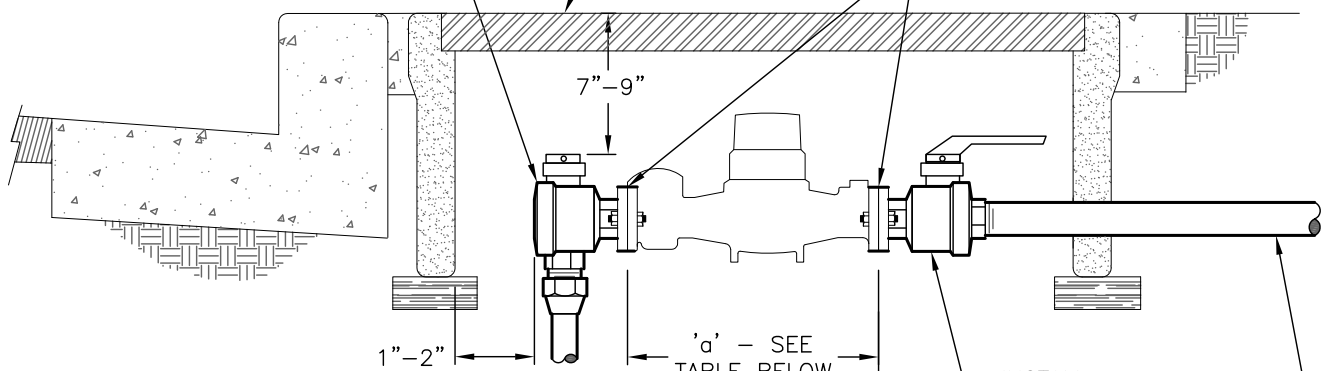

BEND TUBING OR INSTALL  
90° BRASS FITTING.

INSTALL  
CUSTOMER-OPERABLE  
BRASS FIP x FIP CURB  
STOP WITH HANDLE

CITY RESPONSIBILITY    CUSTOMER RESPONSIBILITY

CONSTRUCT LATERAL  
TRENCH PER DETAIL 14

BRASS OR SCH-80 PVC PIPE  
EXTENDING BEYOND BACK OF  
WALK, PROPERTY LINE OR TO  
BACKFLOW PREVENTION DEVICE,  
WHICHEVER IS FURTHEST.

TYPE K SOFT COPPER TUBING.  
KINKED TUBING SHALL BE REJECTED.

STANDARD SERVICE  
CONNECTION PER  
DETAIL 1

**ELEVATION VIEW**

METER SIZE AND TYPE (ASSIGNED BY SCWD)	BOX TYPE (SEE DETAIL 2)	METER LENGTH, a
5/8" THREADED	"16"	7 3/4"
3/4" THREADED	"16"	7 3/4"
1" THREADED	"16"	11"
1 1/2" FLANGED	"36"	13"
2" FLANGED	"36"	15 1/4"

**NOTES**

- BRASS FITTINGS, VALVES AND PIPE SHALL CONSIST OF LOW-LEAD BRASS ALLOY AND SHALL HAVE A MINIMUM WORKING PRESSURE OF 150 PSI.
- METER WILL BE FURNISHED AND INSTALLED BY CITY FORCES
- A BACKFLOW PREVENTION ASSEMBLY SHALL BE INSTALLED PER DETAIL 8 IF REQUIRED BY THE ENGINEER.



**WATER DEPARTMENT**  
CITY OF SANTA CRUZ, CALIFORNIA

**DETAIL 5**  
**2-INCH AND SMALLER SERVICE  
INSTALLATION**

NOT TO SCALE

APPROVED 

RCE 37391

DRAWING No. 3714 A    REVISED DECEMBER 2009  
C:\DOCUMENTS\LOCALS~1\Temp\AcPublish\_3460\DEC2009.dwg

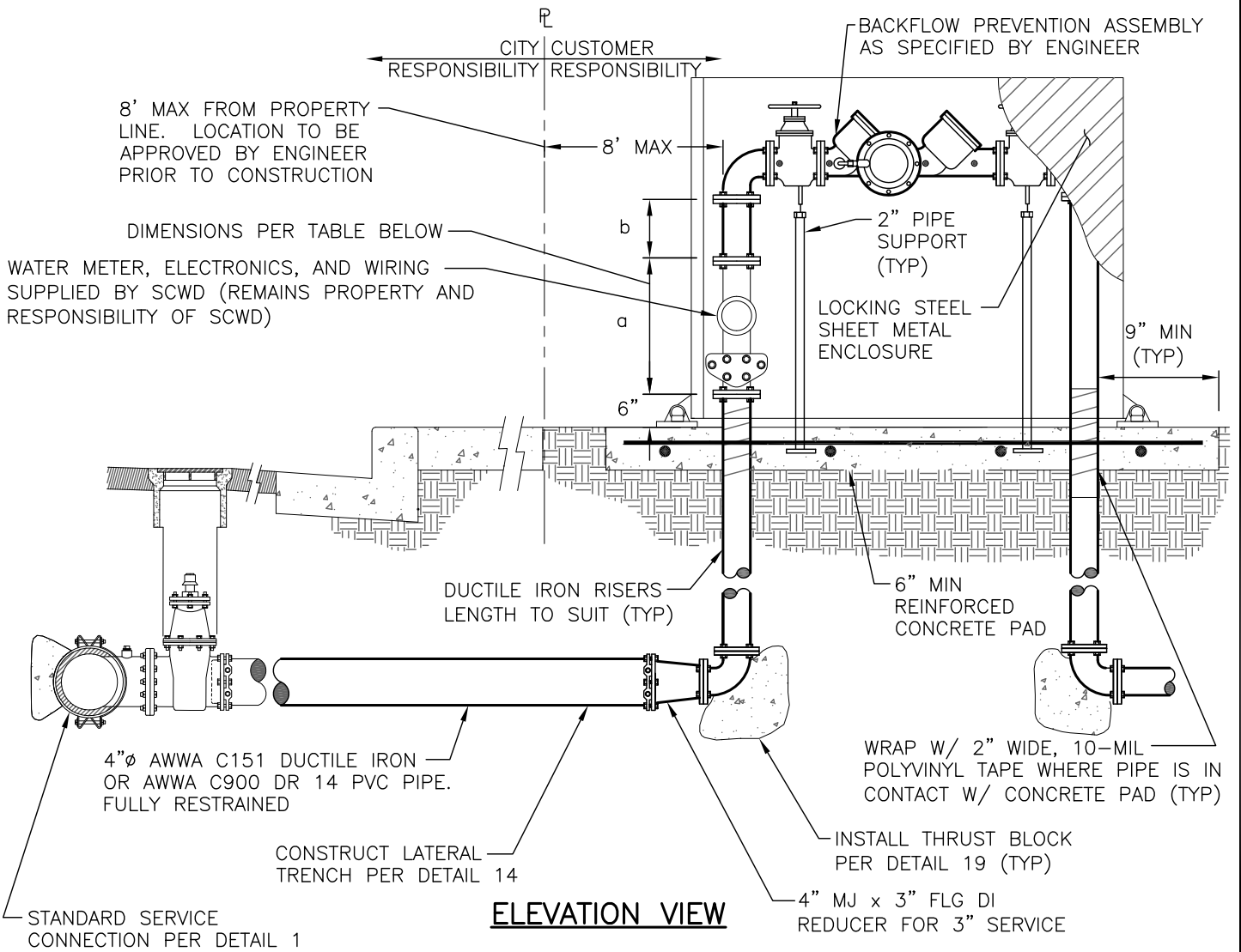

MINIMUM REINFORCING STEEL: #3's @ 12" OC EW OR EQUIVALENT WELDED WIRE MESH

3" MIN CLR. TYP ALL SIDES.

METER SIZE	METER LENGTH, a	STRAIGHT PIPE, b
3"	17"	7½" MIN
4"	20"	10" MIN

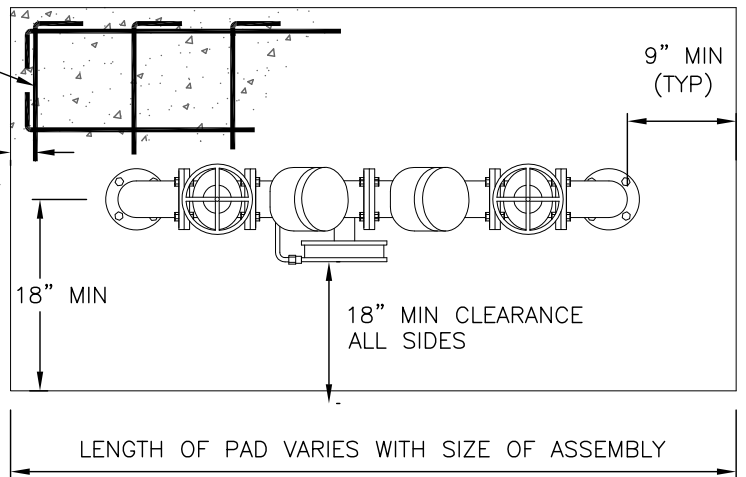

**NOTES**

1. LOCATION OF ASSEMBLY SHALL BE APPROVED BY THE ENGINEER PRIOR TO INSTALLATION
2. ALTERNATE CONFIGURATION WITH METER IN-LINE WITH BACKFLOW ASSEMBLY MAY BE USED AT THE DISCRETION OF THE ENGINEER
3. INSTALL TRAFFIC BOLLARD(S) PER DETAIL 20 IF REQUIRED BY ENGINEER



**WATER DEPARTMENT**  
CITY OF SANTA CRUZ, CALIFORNIA

**DETAIL 6**  
**3-INCH OR 4-INCH SERVICE INSTALLATION**

NOT TO SCALE

---

APPROVED *[Signature]* RCE 37391

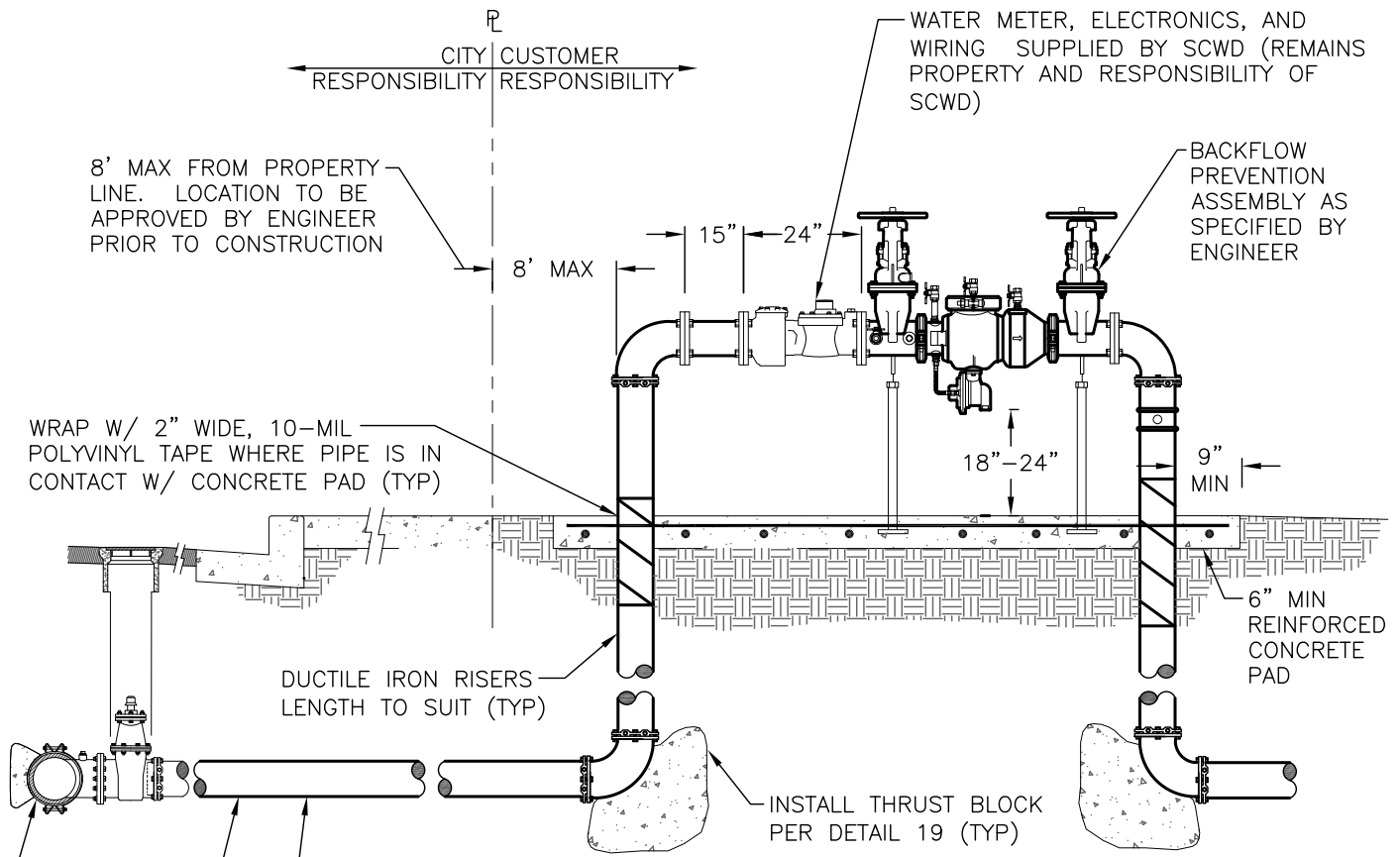

**ELEVATION VIEW**

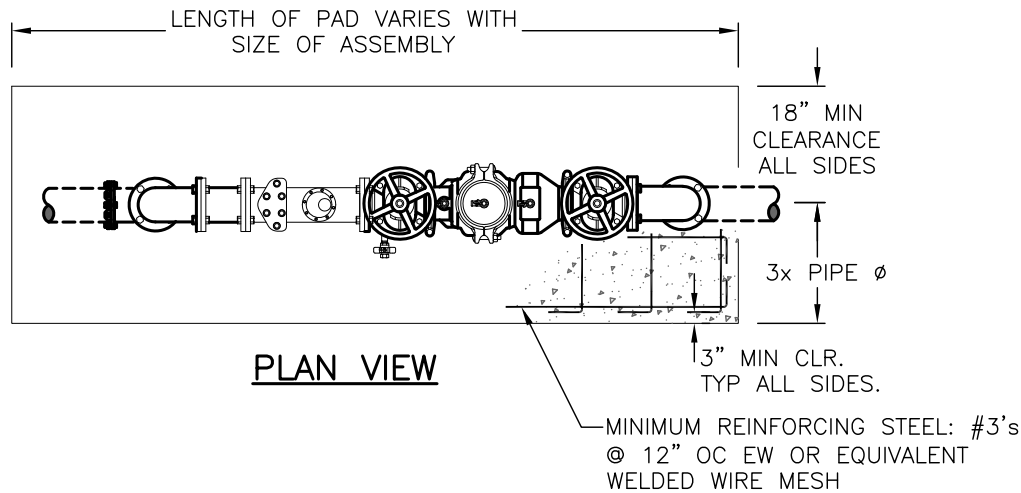

**PLAN VIEW**

**NOTES**

1. LOCATION OF ASSEMBLY SHALL BE APPROVED BY THE ENGINEER PRIOR TO INSTALLATION
2. INSTALL TRAFFIC BOLLARD(S) PER DETAIL 20 IF REQUIRED BY ENGINEER



**WATER DEPARTMENT**  
CITY OF SANTA CRUZ, CALIFORNIA

**DETAIL 7**  
**6-INCH AND LARGER SERVICE INSTALLATION**

NOT TO SCALE

*Sanford Wood*

APPROVED

RCE 37391



FIRE DEPARTMENT CONNECTION AS REQUIRED BY FIRE DISTRICT W/ CLAPPERED SIAMESE, LISTED SCREW-IN PLUGS WITH PIN-LUGS, AND CHECK VALVE

FACE CLAPPERED SIAMESE TOWARD STREET, AWAY FROM OBSTRUCTIONS

CITY CUSTOMER  
RESPONSIBILITY RESPONSIBILITY

8' MAX FROM PROPERTY LINE.  
LOCATION TO BE APPROVED  
BY ENGINEER PRIOR TO  
CONSTRUCTION

8' MAX

2" PIPE  
SUPPORT

6" THICK REINFORCED  
CONCRETE PAD

18"-24"

9"  
MIN

36"  
MIN

DUCTILE IRON RISERS  
LENGTH TO SUIT (TYP)

WRAP W/ 2" WIDE,  
10-MIL POLYVINYL TAPE  
WHERE PIPE IS IN  
CONTACT W/  
CONCRETE PAD  
(TYP)

STANDARD SERVICE  
CONNECTION PER DETAIL 1

ALARM CONDUIT  
AS REQUIRED BY  
FIRE DISTRICT

CONSTRUCT LATERAL  
TRENCH PER DETAIL 14

INSTALL THRUST BLOCK  
PER DETAIL 19 (TYP)

RESTRAINED  
JOINT (TYP)

AWWA C151 DUCTILE IRON OR  
AWWA C900 DR 14 PVC PIPE,  
FULLY RESTRAINED

### ELEVATION VIEW

BYPASS METER FURNISHED BY SCWD.  
(REQ'D. SPACE= 7-3/4")

DOUBLE CHECK DETECTOR ASSEMBLY  
-OR-

REDUCED PRESSURE PRINCIPLE DETECTOR  
ASSEMBLY AS SPECIFIED BY SCWD

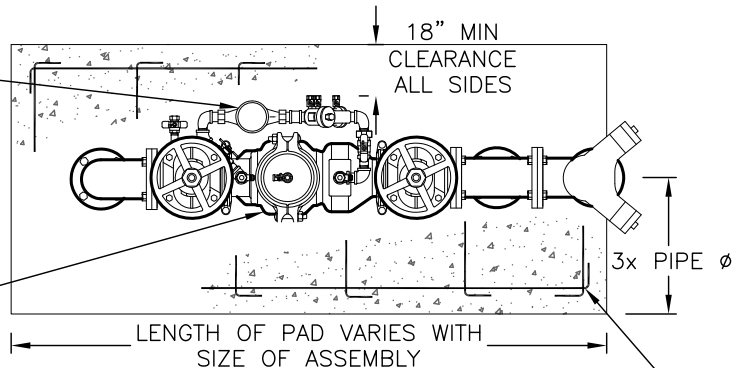

MINIMUM REINFORCING STEEL: #3's @ 12" OC  
EW OR EQUIVALENT WELDED WIRE MESH

### PLAN VIEW

### NOTES

1. REFER TO PROJECT CIVIL PLAN FOR REQUIRED TYPE OF DEVICE OR CALL SCWD AT (831) 420-5210 FOR SPECIFIED TYPE PRIOR TO INSTALLATION.
2. O.S. AND Y. VALVES SHALL BE EQUIPPED WITH TAMPER PROOF ALARM DEVICES. VALVES ARE TO BE CHAINED TOGETHER IN THE OPEN POSITION WITH A BREAK-AWAY CHAIN OR AS REQUIRED BY FIRE DISTRICT.
3. ASSEMBLY TO BE PAINTED RED OR OTHER COLOR AS SPECIFIED BY FIRE DISTRICT.
4. DEVICE MUST BE INSTALLED SO THAT IT IS READILY ACCESSIBLE FOR TESTING AND MAINTENANCE. LOCATIONS MUST BE APPROVED BY SCWD PRIOR TO INSTALLATION.
5. INSTALL TRAFFIC BOLLARD(S) PER DETAIL 20 IF REQUIRED BY ENGINEER
6. BRASS OR PLASTIC PLUGS SHALL BE INSTALLED ON ALL TEST PORTS.



WATER DEPARTMENT  
CITY OF SANTA CRUZ, CALIFORNIA

DETAIL 9  
STANDARD 4-INCH AND LARGER FIRE  
SERVICE INSTALLATION

NOT TO SCALE

APPROVED *Sanford Wood*

RCE 37391

6" BREAK-AWAY EXTENSION WITH HOLLOW BREAK-AWAY BOLTS (BOLT HEADS ON TOP THREADS HANG DOWN)

PAINT HYDRANT HEAD & BREAK-AWAY W/ POST INTERNATIONAL YELLOW ENAMEL.

RECONSTRUCT SIDEWALK, CURB AND GUTTER PER DEPT OF PUBLIC WORKS SPECIFICATIONS AND DETAILS

WRAP W/ 2" WIDE, 10-MIL POLYVINYL TAPE WHERE PIPE IS IN CONTACT W/ CONCRETE PAD (TYP)

PAVEMENT

CONSTRUCT LATERAL TRENCH PER DETAIL 14

MJ HYDRANT BURY LENGTH TO SUIT

INSTALL THRUST BLOCK PER DETAIL 19

STANDARD SERVICE CONNECTION PER DETAIL 1

6" Ø AWWA C151 DUCTILE IRON OR AWWA C900 DR 14 PVC PIPE FULLY RESTRAINED

HYDRANT SHALL CONNECT TO 6" MIN Ø MAIN

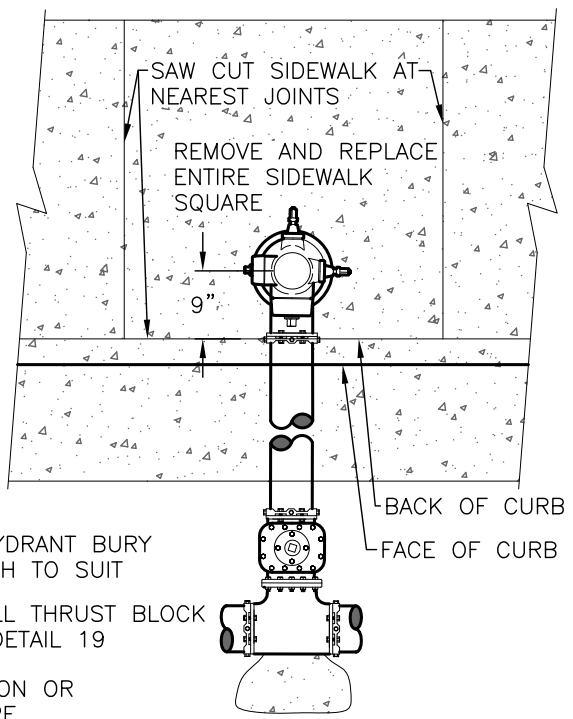

MJ HYDRANT BURY

**TYPICAL IN-SIDEWALK INSTALLATION**

INSTALL TRAFFIC BOLLARD(S) PER DETAIL 20 WHERE REQUIRED BY ENGINEER

INSTALLED HEIGHT OF HYDRANT PLUS 4"

3' MIN

SLOPE AWAY 2% MIN

WHEN HYDRANT IS NOT IN SIDEWALK, CENTER HYDRANT IN 6"x4"x4" REINFORCED CONCRETE PAD.

3" MIN CLR. TYP ALL SIDES.

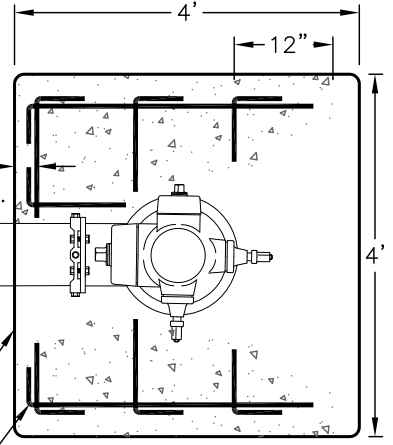

MINIMUM REINFORCING STEEL: #3's @ 12" OC EW OR EQUIVALENT WELDED WIRE MESH

**ALTERNATE INSTALLATION**

**NOTES**

1. HYDRANT SHALL BE 6" "STEAMER" TYPE; CLOW MODEL 2060, JONES MODEL J-3760, OR APPROVED EQUAL.
2. REMOVE HYDRANT OUTLET CAP CHAINS PERMANENTLY.
3. HYDRANT SHALL BE COVERED WITH BURLAP SACK OR APPROVED ORANGE BAG WHEN NOT IN SERVICE.
4. FIRE HYDRANT LOCATION SHALL BE APPROVED ON A CASE BY CASE BASIS PRIOR TO CONSTRUCTION AND SHALL INCLUDE FIRE AGENCY APPROVED PLANS, CITY OR COUNTY ENCROACHMENT PERMIT, AND FIELD VERIFICATION BY THE APPROPRIATE FIRE AGENCY, CITY OR COUNTY PUBLIC WORKS DEPARTMENT AND SCWD, PER SCWD HYDRANT INSTALLATION PERMIT REQUIREMENTS PRIOR TO CONSTRUCTION.



**WATER DEPARTMENT**  
CITY OF SANTA CRUZ, CALIFORNIA

**DETAIL 10**

**FIRE HYDRANT INSTALLATION**

NOT TO SCALE

APPROVED *[Signature]*

RCE 37391

DRAWING No. 2993 A REVISED DECEMBER 2009 C:\DOCUMENTS\LOCALS\1\Temp\AcPublish\3460\DEC2009.dwg

USE OF GRADE RINGS PROHIBITED

BOX AND RISER SHALL BE CENTERED OVER GATE VALVE, AND ALIGNED WITH VALVE STEM AXIS.

CHRISTY G-5 VALVE BOX W/ G5C LID OR EQUAL.

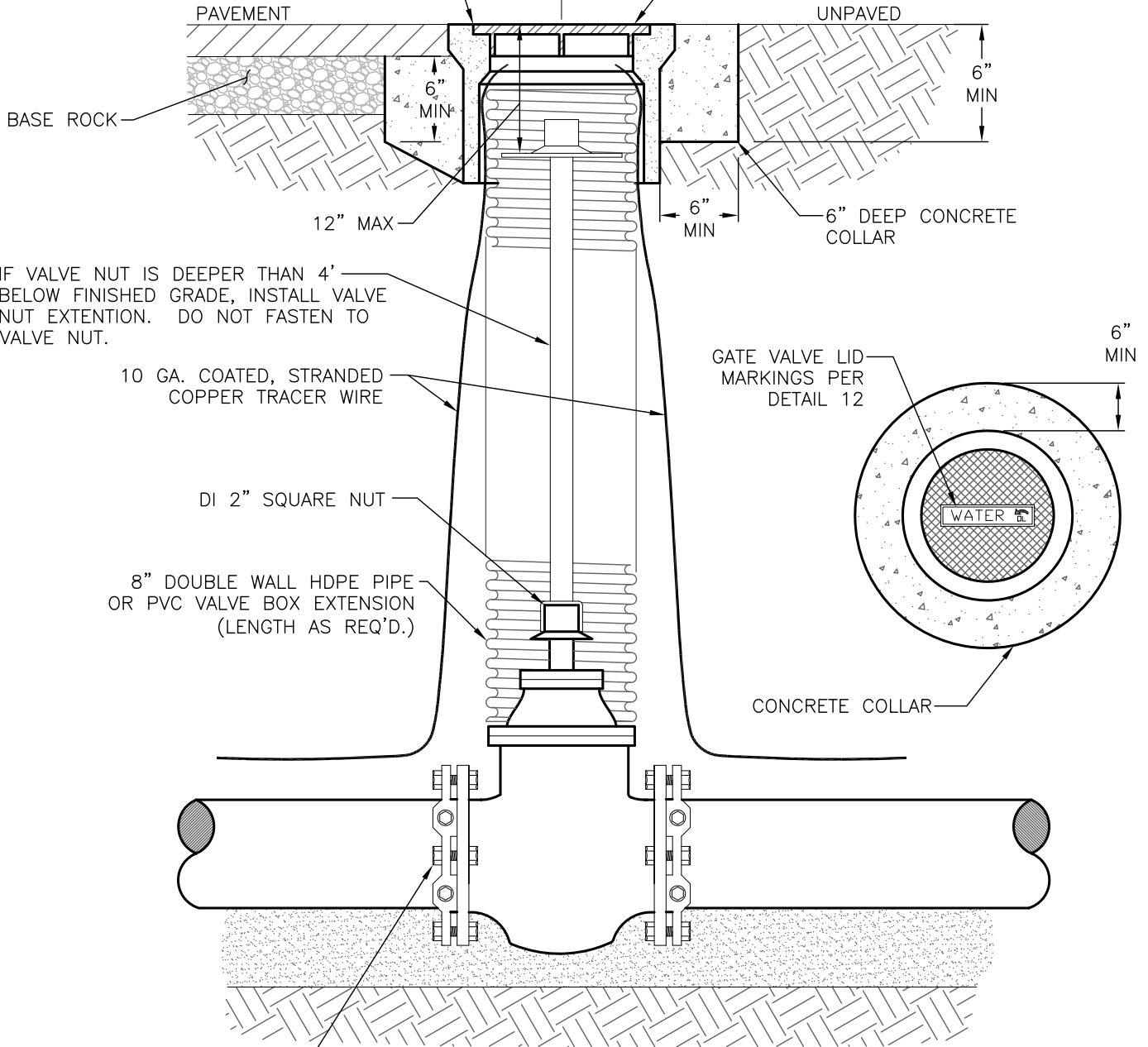

IF VALVE NUT IS DEEPER THAN 4' BELOW FINISHED GRADE, INSTALL VALVE NUT EXTENTION. DO NOT FASTEN TO VALVE NUT.

10 GA. COATED, STRANDED COPPER TRACER WIRE

DI 2" SQUARE NUT

8" DOUBLE WALL HDPE PIPE OR PVC VALVE BOX EXTENSION (LENGTH AS REQ'D.)

GATE VALVE LID MARKINGS PER DETAIL 12

CONCRETE COLLAR

COAT ALL MJ AND JOINT-RESTRAINT BOLTS WITH BITUMASTIC

**NOTES**

1. VALVE BOX LID SHALL BE OILED PRIOR TO PAVING OR CLEANING TO ENSURE THAT LID MARKINGS ARE LEGIBLE.
2. INSTALL VALVE BOX LID FLUSH WITH FINAL PAVING OR GROUND SURFACE.
3. INSTALL BLOCKING UNDER VALVE IF REQUIRED.

 <p><b>CITY OF SANTA CRUZ</b></p>	<p><b>WATER DEPARTMENT</b> CITY OF SANTA CRUZ, CALIFORNIA</p>
	<p><b>DETAIL 11</b> <b>GATE VALVE INSTALLATION</b></p>
<p>NOT TO SCALE</p>	
<p>APPROVED <i>[Signature]</i></p>	<p>RCE 37391</p>

DRAWING No. 2994 A REVISED JANUARY 2009  
 C:\DOCUMENTS\LOCALS\1\Temp\AcPublish\_3460\DEC2009.dwg



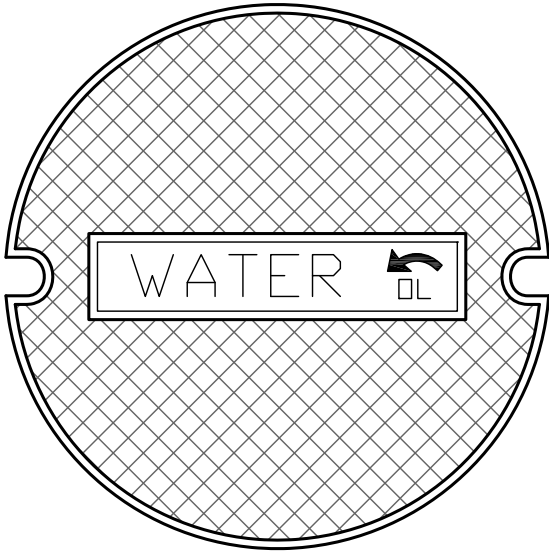

STANDARD VALVE BOX LID  
FOR MAIN LINE VALVES



STANDARD VALVE BOX LID  
FOR ALL NORMALLY CLOSED  
ZONE VALVES

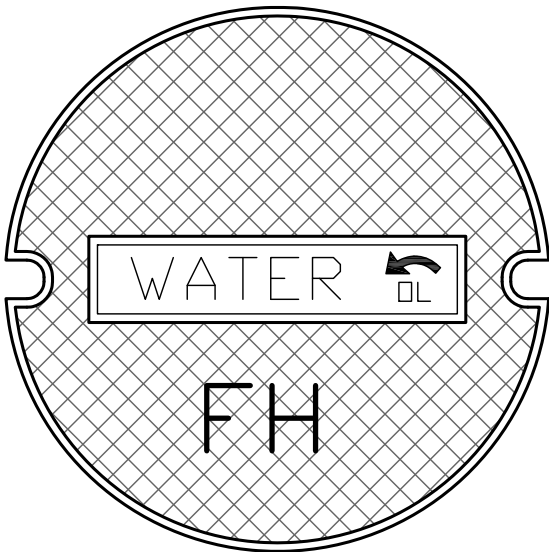

STANDARD VALVE BOX LID FOR  
ALL FIRE HYDRANT VALVES

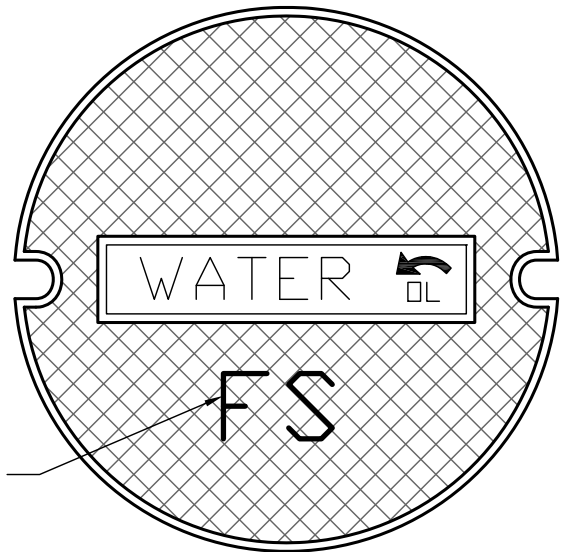

WELD MARKINGS ON  
TO LID (TYP)

STANDARD VALVE BOX LID  
FOR ALL FIRE SERVICES

DRAWING No. 3684 A REVISED DECEMBER, 2009  
C:\DOCUMENT~1\kocoda\LOCALS~1\Temp\AcPublish\_3460\DEC2009.dwg

	<p><b>WATER DEPARTMENT</b> CITY OF SANTA CRUZ, CALIFORNIA</p>
	<p><b>DETAIL 12</b> VALVE BOX LID MARKINGS</p>
<p>NOT TO SCALE</p>	
<p>APPROVED <i>[Signature]</i></p>	<p>RCE 37391</p>

\* This page left intentionally blank \*

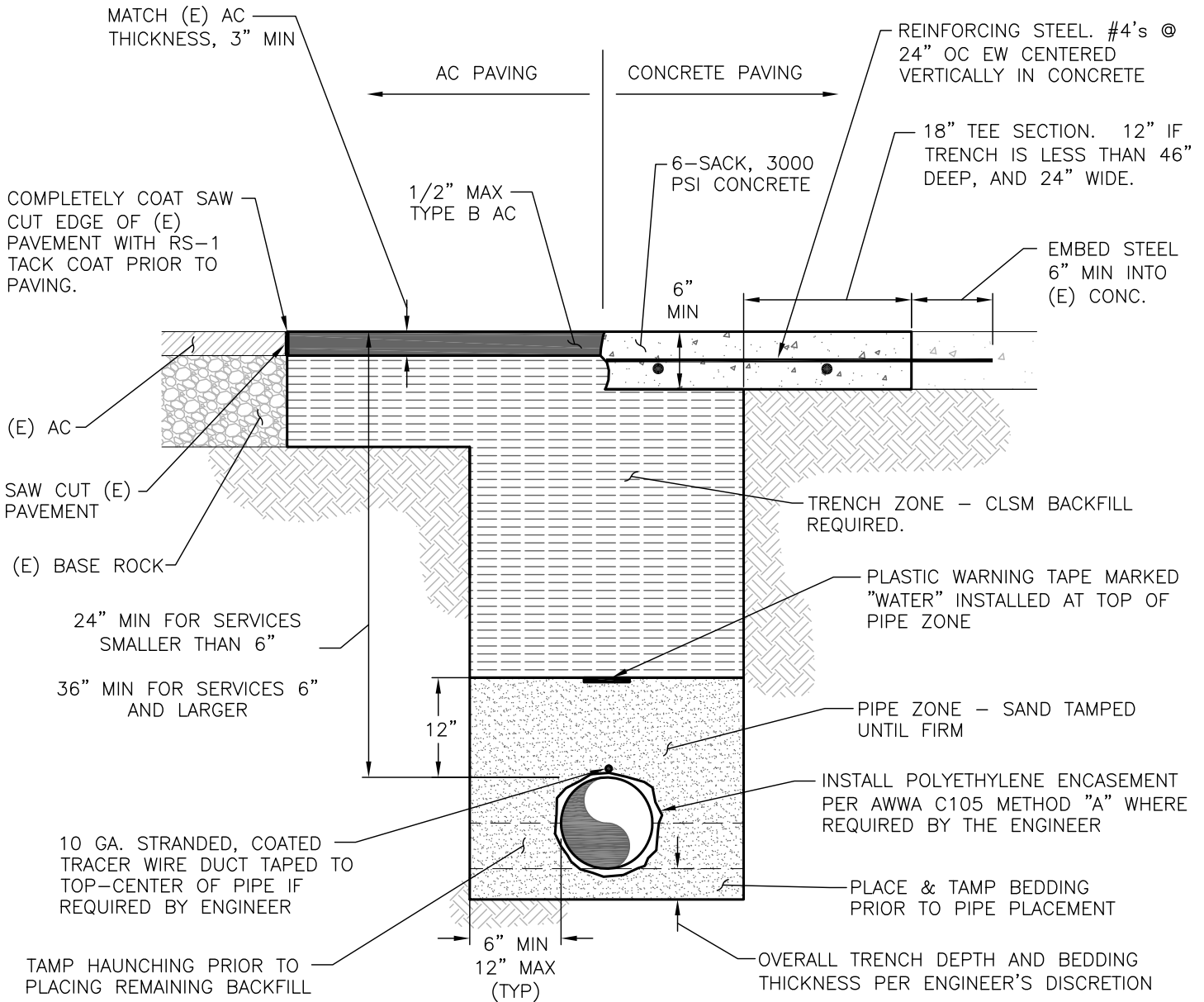

### STANDARD SERVICE LATERAL TRENCH

#### NOTES

1. IF ANY PORTION OF (E) PAVEMENT WITHIN SAWCUT LIMITS IS CONCRETE AT THE SURFACE, ENTIRE TRENCH SHALL BE RE-PAVED WITH CONCRETE AS SHOWN.
2. WHERE WATER SERVICES 6" AND LARGER CANNOT MEET MINIMUM COVER REQUIREMENTS, THE ENGINEER MAY APPROVE ALTERNATE INSTALLATION PER DETAIL 16.
3. ALL JOINTS ON SERVICE LATERALS SHALL BE RESTRAINED.



**CITY OF  
SANTA CRUZ**

**WATER DEPARTMENT**  
CITY OF SANTA CRUZ, CALIFORNIA

**DETAIL 14**

**STANDARD SERVICE LATERAL TRENCH**

NOT TO SCALE

APPROVED *[Signature]*

RCE 37391

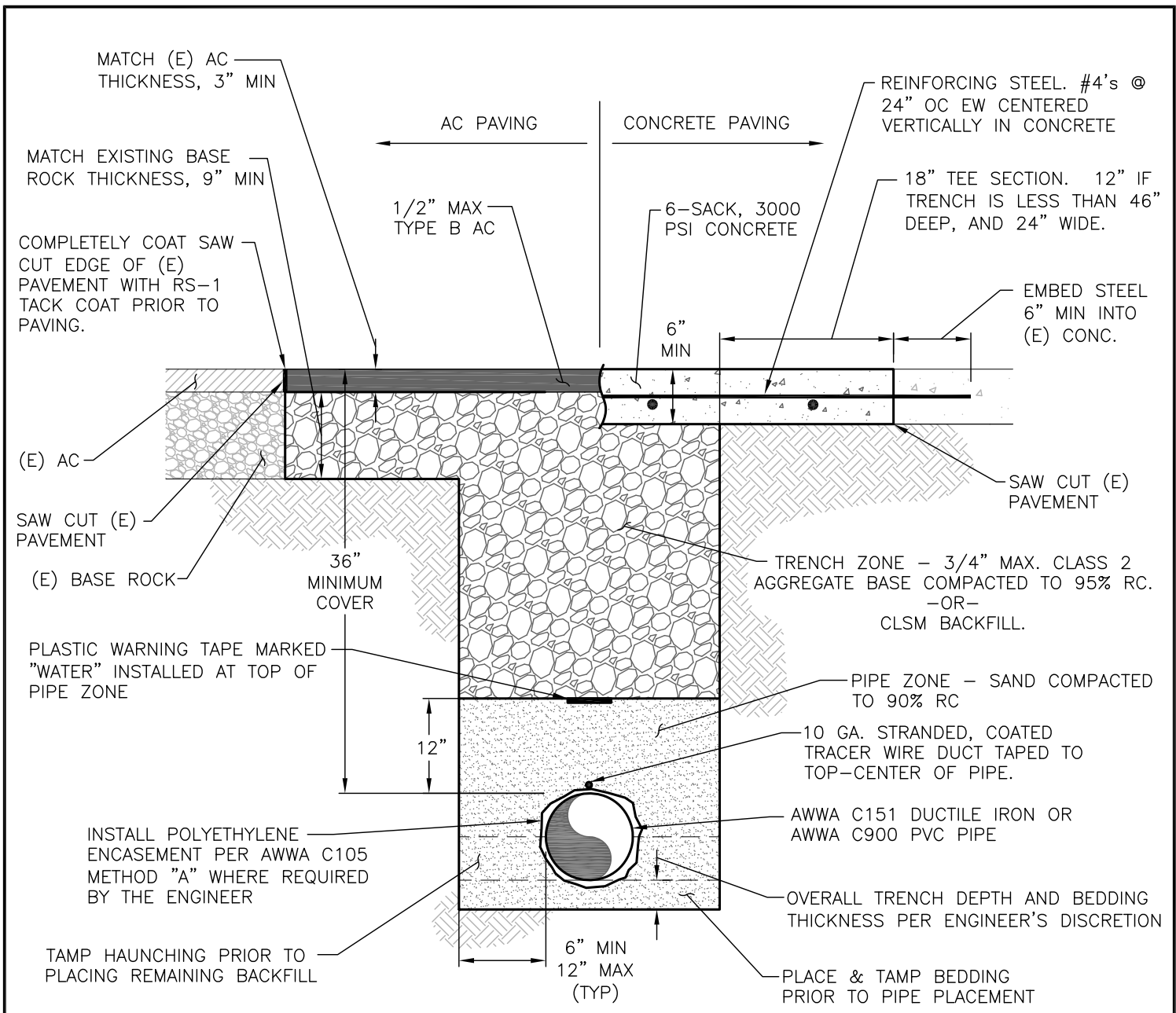

**STANDARD WATER MAIN TRENCH**

**NOTES**

1. IF ANY PORTION OF (E) PAVEMENT WITHIN SAWCUT LIMITS IS CONCRETE AT THE SURFACE, ENTIRE TRENCH SHALL BE RE-PAVED WITH CONCRETE AS SHOWN,
2. WHERE WATER MAIN INSTALLATION CANNOT MEET MINIMUM COVER REQUIREMENTS, THE ENGINEER MAY APPROVE ALTERNATE INSTALLATION PER DETAIL 16.
3. REFER TO SCWD TECHNICAL SPECIFICATIONS FOR COMPACTION TESTING REQUIREMENTS.
4. FOR SERVICE LATERALS, REFER TO DETAIL 14.



**CITY OF  
SANTA CRUZ**

**WATER DEPARTMENT**  
CITY OF SANTA CRUZ, CALIFORNIA  
**DETAIL 15**  
**STANDARD WATER MAIN TRENCH**

NOT TO SCALE

APPROVED *[Signature]*

RCE 37391

DRAWING No. 3718 A REVISED DECEMBER 2009 C:\DOCUMENTS\LOCALS\1\Temp\AcPublish\_3460\DEC2009.dwg

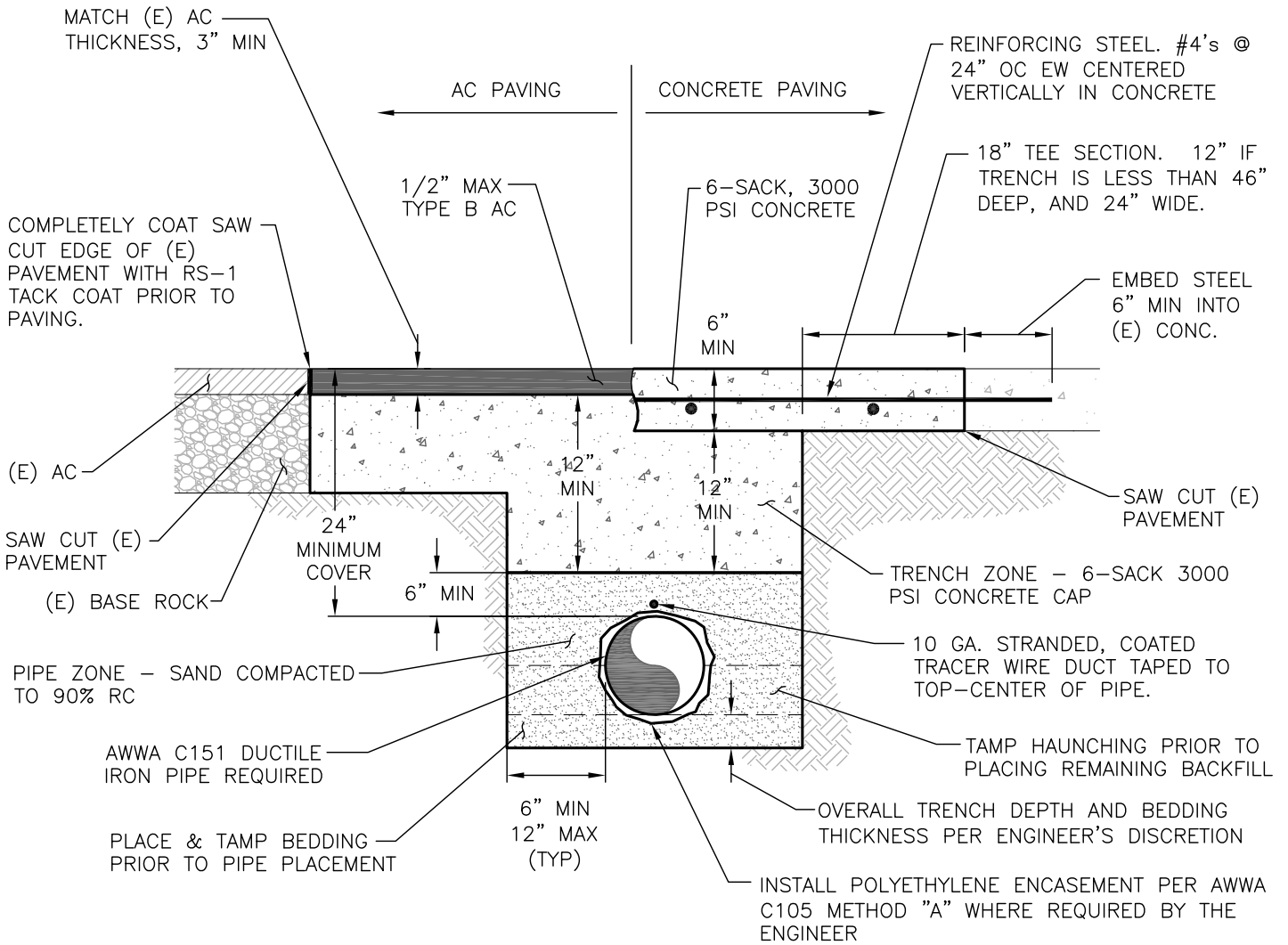

### WATER MAIN TRENCH

FOR MAINS INSTALLED AT SUB-STANDARD DEPTH

**NOTES**

1. USE OF THIS DETAIL REQUIRES PRIOR APPROVAL OF THE ENGINEER. REFER TO DETAIL 15 FOR STANDARD TRENCH
2. IF ANY PORTION OF (E) PAVEMENT WITHIN SAWCUT LIMITS IS CONCRETE AT THE SURFACE, ENTIRE TRENCH SHALL BE RE-PAVED WITH CONCRETE AS SHOWN,
3. REFER TO SCWD TECHNICAL SPECIFICATIONS FOR COMPACTION TESTING REQUIREMENTS.
4. FOR SERVICE LATERALS REFER TO DETAIL 14.

 <p><b>CITY OF SANTA CRUZ</b></p>	<p><b>WATER DEPARTMENT</b> CITY OF SANTA CRUZ, CALIFORNIA</p> <p><b>DETAIL 16</b></p> <p><b>SUB-STANDARD WATER MAIN TRENCH</b></p> <p>NOT TO SCALE</p>
<p>APPROVED <i>[Signature]</i></p>	<p>RCE 37391</p>

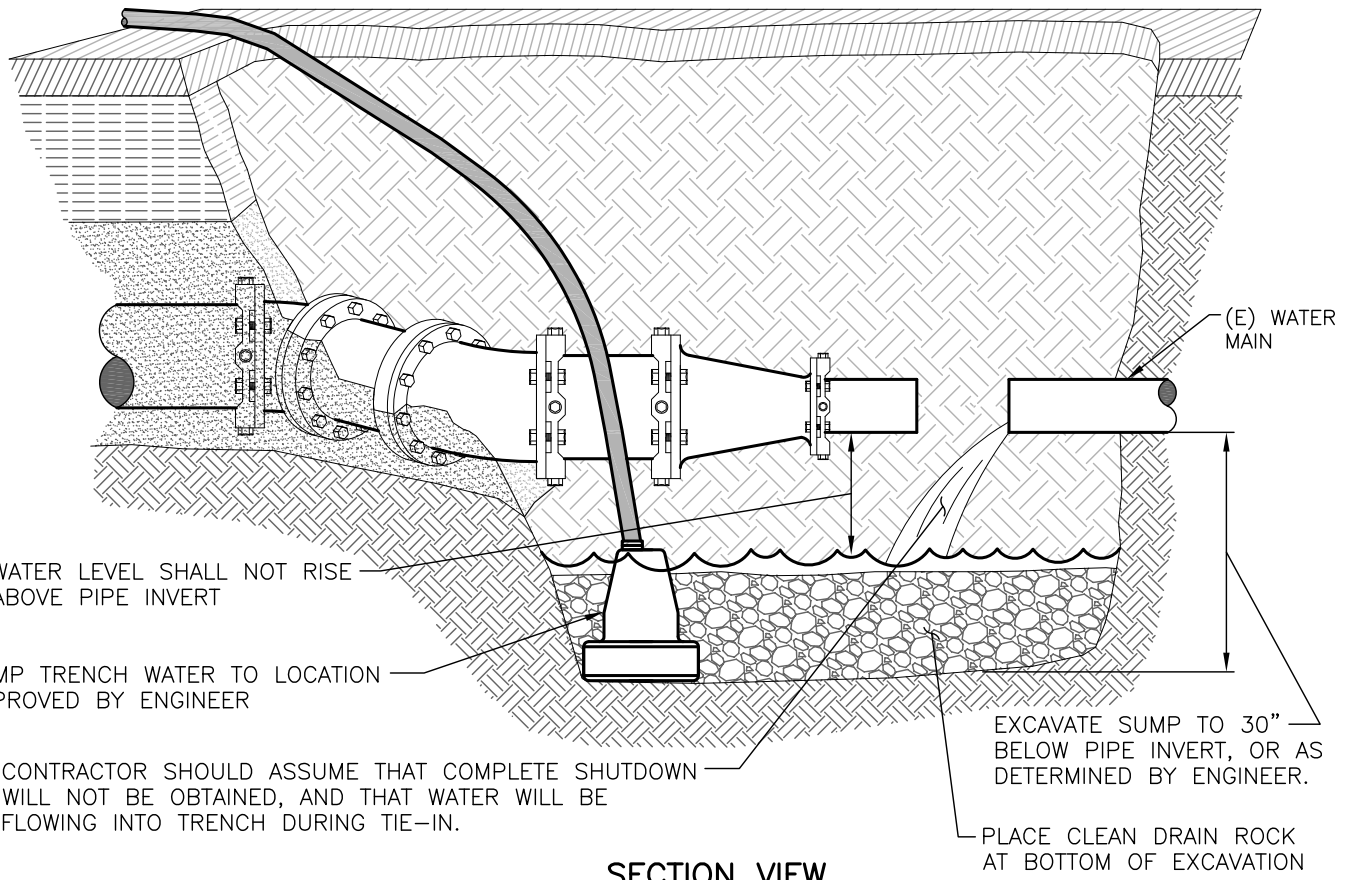

**SECTION VIEW**

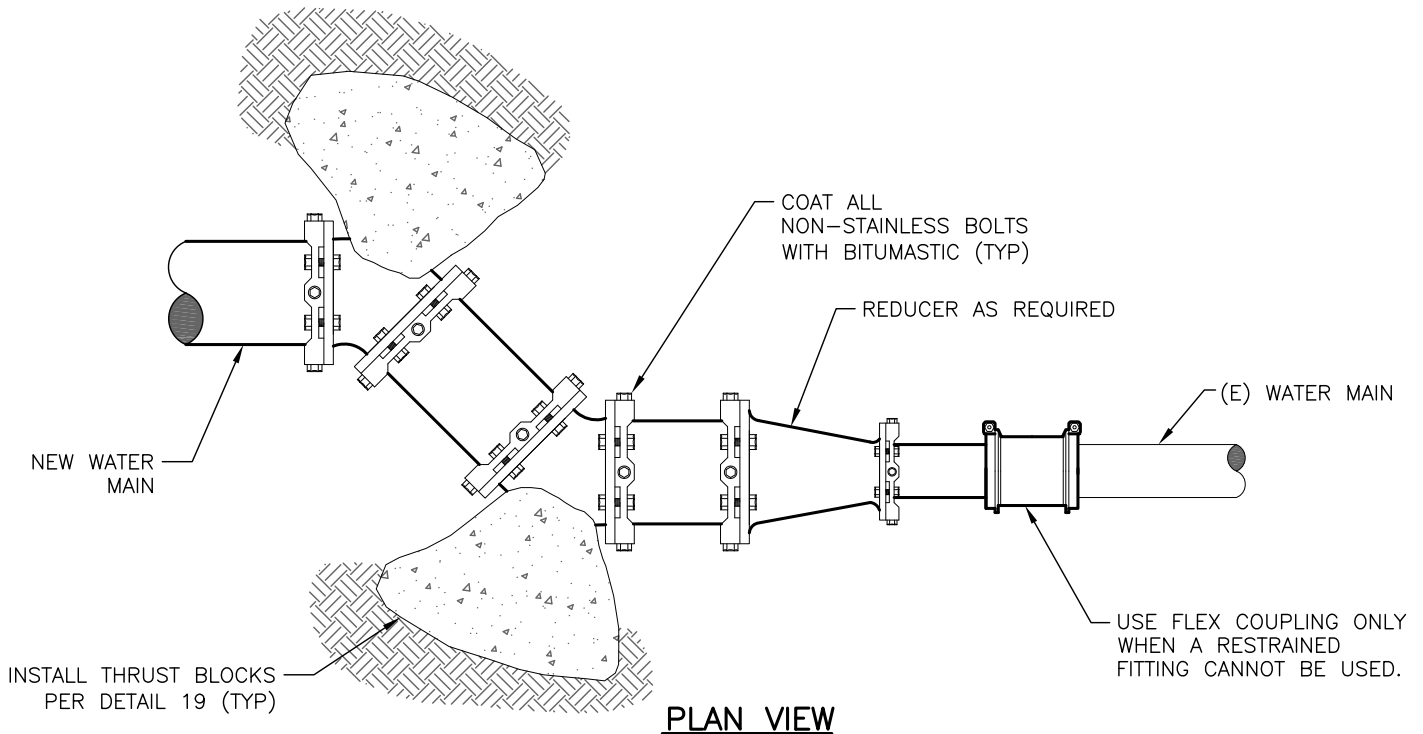

**PLAN VIEW**

**NOTES**

1. CONTRACTOR SHALL VERIFY (E) MAIN DIAMETER PRIOR TO SCHEDULING SYSTEM SHUT DOWN.
2. ELBOWS SHARPER THAN 45° ARE NOT ALLOWED.
3. PIPE AND FITTING SIZES & MATERIAL SHALL BE SPECIFIED BY ENGINEER.
4. JOINT RESTRAINTS AND THRUST BLOCKING PER DETAILS 19 AND 20 ARE REQUIRED.
5. TEMPORARY THRUST BLOCKING MAY BE REQUIRED WHILE CONCRETE CURES.

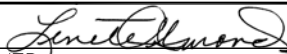
	<b>WATER DEPARTMENT</b>
	CITY OF SANTA CRUZ, CALIFORNIA
<b>DETAIL 17</b>	
<b>SYSTEM CONNECTION (TIE IN)</b>	
NOT TO SCALE	
 APPROVED	RCE 37391

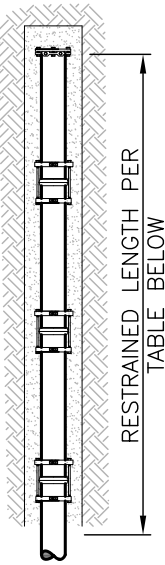

**PLUG, CAP OR VALVE**

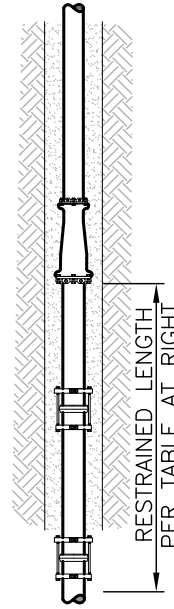

**REDUCER**

DIFFERENCE IN PIPE DIAMETER	REQUIRED RESTRAINT LENGTH (FT)
2"	25'
4"	50'
6"	65'

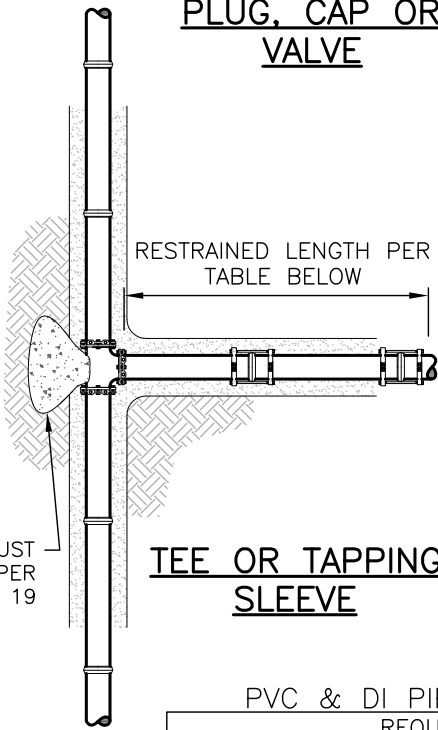

**TEE OR TAPPING SLEEVE**

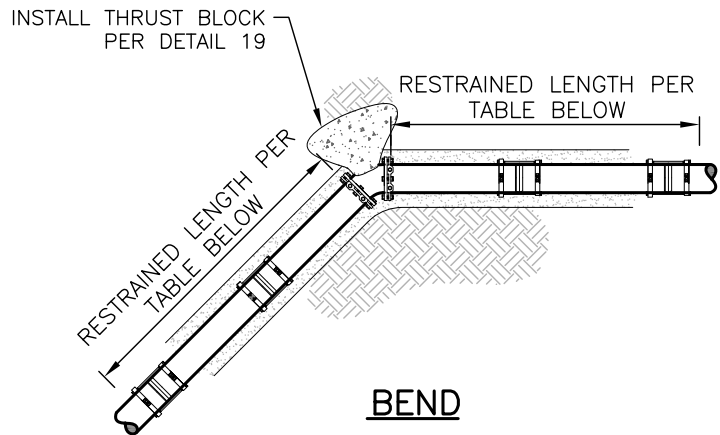

**BEND**

**PVC & DI PIPE JOINT RESTRAINT SIZING TABLE**  
REQUIRED RESTRAINT DISTANCE (FT.)

PIPE DIA.	TEE BRANCH	PLUG, CAP, OR VALVE	VERTICAL BEND				HORIZONTAL BEND			
			11 1/4°	22 1/2°	45°	11 1/4°	22 1/2°	45°	90°	
4	20	35	5	10	15	5	5	10	15	
6	20	45	5	10	20	5	5	10	20	
8	20	60	10	15	25	5	10	15	30	
10	20	75	10	15	30	5	10	15	35	

**NOTES**

1. ALL UNCOATED JOINT RESTRAINT AND FITTING HARDWARE SHALL BE COATED WITH BITUMASTIC.
2. THRUST BLOCKING PER DETAIL 19 IS REQUIRED.
3. RESTRAINED LENGTHS FOR PIPES LARGER THAN 10 INCHES IN DIAMETER SHALL BE DESIGNED BY THE ENGINEER.
4. SERVICE LATERALS SHALL BE FULLY RESTRAINED.



**CITY OF SANTA CRUZ**

**WATER DEPARTMENT**  
CITY OF SANTA CRUZ, CALIFORNIA

**DETAIL 18**

**JOINT RESTRAINT INSTALLATION**

NOT TO SCALE

APPROVED *[Signature]*

RCE 37391

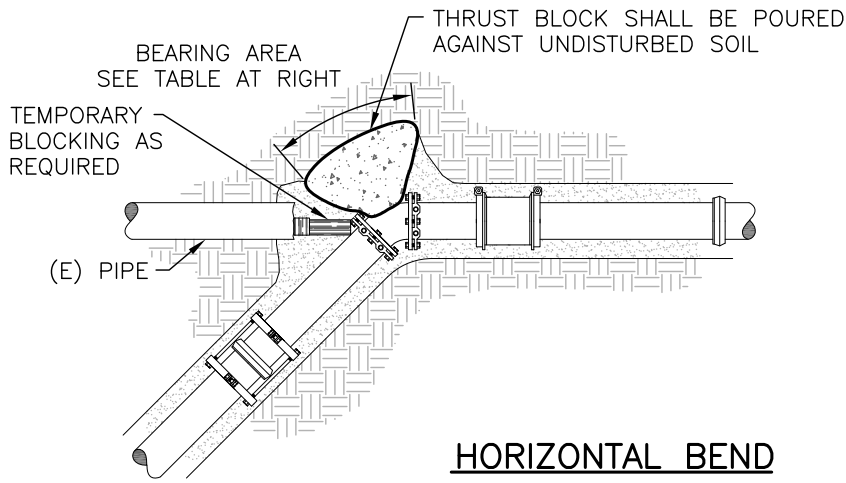

**HORIZONTAL BEND**

**THRUST BLOCK BEARING AREA (SQUARE FEET)**

		FITTING DEFLECTION			
		11 1/4°	22 1/2°	45°	90°
PIPE DIAMETER	4"	1	1	2	2
	6"	1	1	2	4
	8"	1	2	4	7
	10"	2	3	6	11

PIPE DIAMETER	BEARING AREA (SQUARE FEET)
4"	2
6"	3
8"	5
10"	8

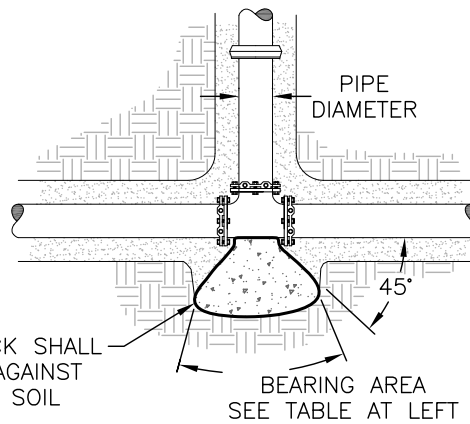

**TEE**

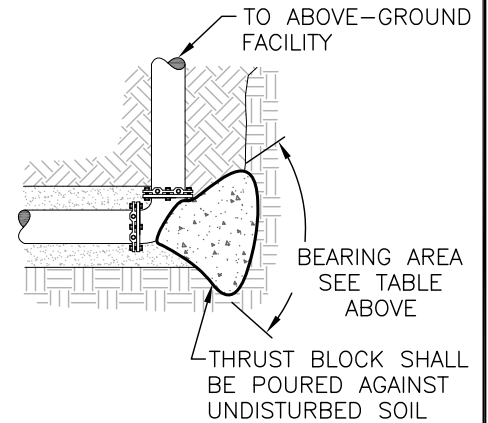

**UPWARD VERTICAL BEND**

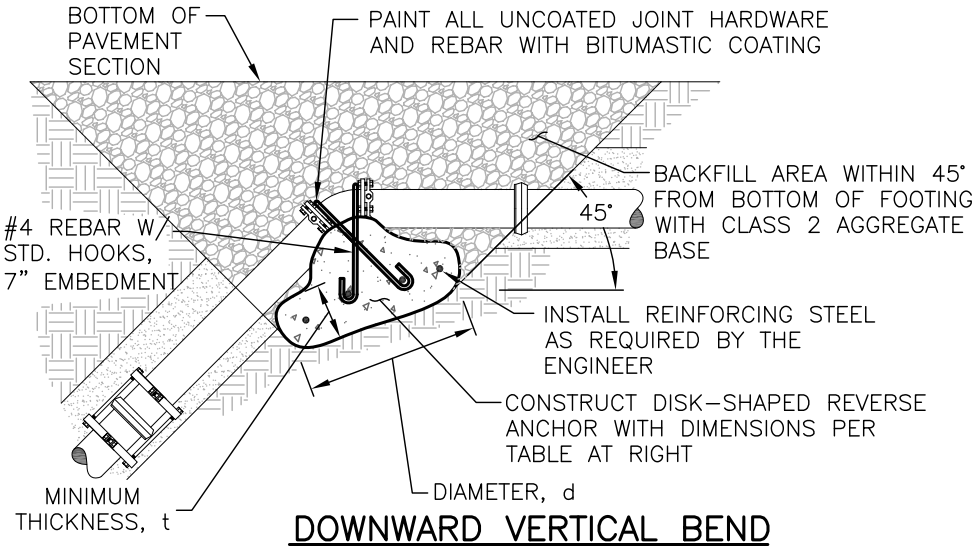

**DOWNWARD VERTICAL BEND**

**MINIMUM REVERSE ANCHOR DIMENSIONS (FEET)**

d / t		FITTING DEFLECTION	
		22 1/2°	45°
PIPE DIAMETER	6"	2 / 0.5	3 / 0.5
	8"	3 / 0.5	4 / 0.8
	10"	3 / 0.5	5.5 / 2

**NOTES**

1. CONCRETE THRUST BLOCKS SHALL BE INSTALLED WHEN INDICATED BY THE CONTRACT DOCUMENTS OR AT THE DISCRETION OF THE ENGINEER.
2. THRUST BLOCKING IS REQUIRED WHERE IT IS UNKNOWN IF PIPE IS RESTRAINED, SUCH AS AT A CONNECTION TO EXISTING PIPE.
3. ALL CONCRETE SHALL BE 3000 PSI MINIMUM 28 DAYS COMPRESSIVE STRENGTH.
4. FOR PIPELINES LARGER THAN 10" IN DIAMETER, PIPELINES INSTALLED AT DEPTHS LESS THAN 36 INCHES, OR IN POOR SOILS, THRUST BLOCK DESIGN SHALL BE APPROVED BY THE ENGINEER ON A CASE BY CASE BASIS.



**WATER DEPARTMENT**  
CITY OF SANTA CRUZ, CALIFORNIA

**DETAIL 19**

**THRUST BLOCK INSTALLATION**

NOT TO SCALE

APPROVED 

RCE 37391



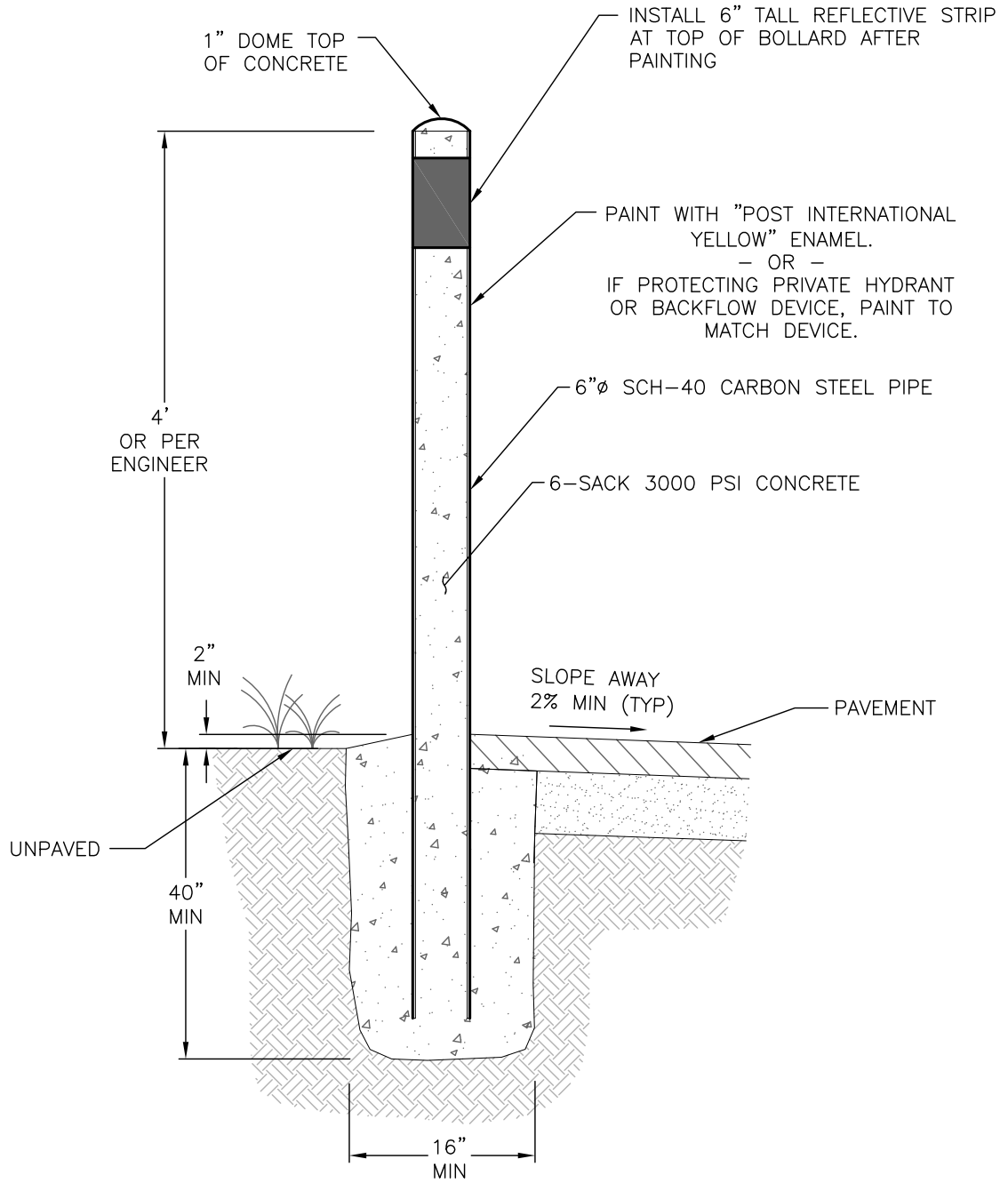

DRAWING No. 3709 A REVISED DECEMBER, 2009  
 C:\DOCUMENT~1\kocodd\LOCALS~1\Temp\AcPublish\_3460\DEC2009.dwg

	<b>WATER DEPARTMENT</b> CITY OF SANTA CRUZ, CALIFORNIA
	<b>DETAIL 20</b> <b>TRAFFIC BOLLARD INSTALLATION</b>
NOT TO SCALE	
APPROVED <i>[Signature]</i>	RCE 37391

1/4" COPPER TUBING WITH 180° BEND. POINT SAMPLE SPOUT AWAY FROM STREET

(2) 1/4" BALL VALVE WITH CHROME PLATED BALL, TEFLON SEATS, AND STEEL HANDLE

1/4" COMPRESSION FITTING (TYP)

1/4" COPPER TUBE IN 3/4" HDPE SLEEVE

TYPE K SOFT COPPER TUBING. KINKED TUBING SHALL BE REJECTED.

1/4" COMPRESSION FITTING

3/4" x 1/4" BELL REDUCER

STANDARD 3/4"-INCH SERVICE CONNECTION PER DETAIL 1

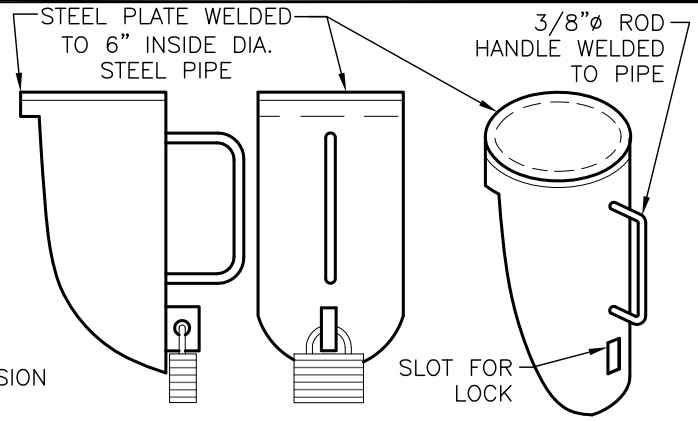

SIDE FRONT PERSPECTIVE

**ENCLOSURE LID**

PAINT ALL STEEL PARTS WITH TWO COATS HUNTER GREEN ENAMEL

6" OUTSIDE DIA. STEEL PIPE

3/4" DRAIN ROCK

FOR UNPAVED INSTALLATION, MAINTAIN 2% MIN SLOPE AWAY FROM ENCLOSURE BASE

FOR IN-SIDEWALK INSTALLATION, SAMPLE STATION SHALL BE CENTERED 9" FROM BACK OF CURB AND 3' MIN. CLEAR OF SIDEWALK WIDTH SHALL BE MAINTAINED AROUND BACK OF SAMPLE STATION.

RECONSTRUCT SIDEWALK, CURB AND GUTTER PER DEPT OF PUBLIC WORKS SPECIFICATIONS AND DETAILS

CONCRETE FOOTING SAND

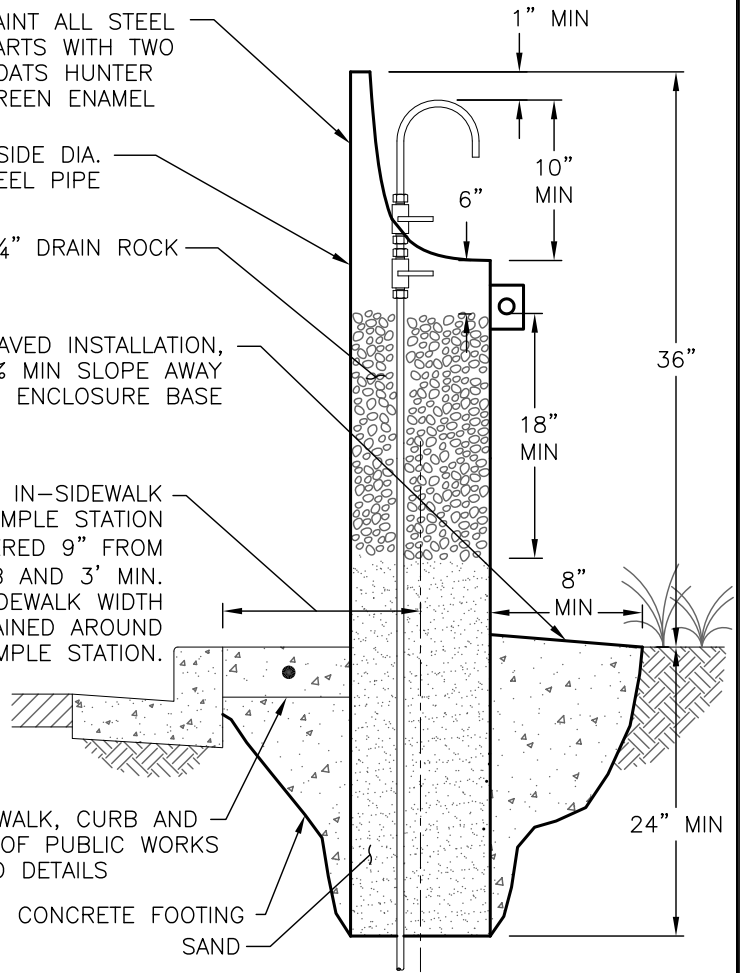

**ENCLOSURE**

**NOTES**

- BRASS FITTINGS, VALVES AND PIPE SHALL CONSIST OF LOW-LEAD BRASS ALLOY AND SHALL HAVE A MINIMUM WORKING PRESSURE OF 150 PSI.
- INSTALL TRAFFIC BOLLARD(S) PER DETAIL 20 WHERE REQUIRED BY THE ENGINEER.



**CITY OF SANTA CRUZ**

**WATER DEPARTMENT**  
CITY OF SANTA CRUZ, CALIFORNIA

**DETAIL 21**

**SAMPLE STATION INSTALLATION**

NOT TO SCALE

*Sanford*

APPROVED

RCE 37391

DRAWING No. 3336 A REVISED DECEMBER, 2009 C:\DOCUMENTS\LOCALS\1\Temp\AcPublish\_3460\DEC2009.dwg

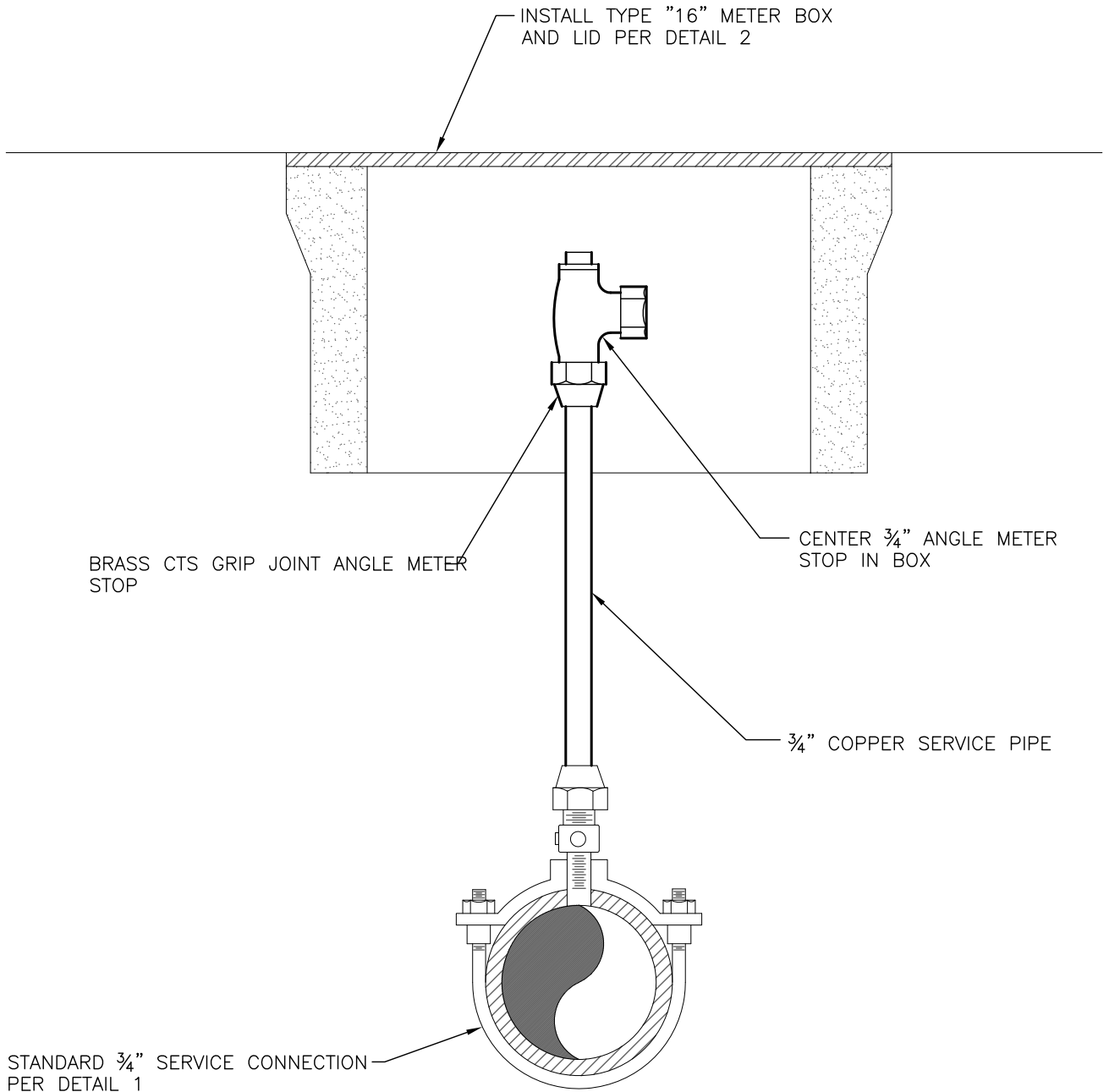

**NOTES**

1. BRASS FITTINGS, VALVES AND PIPE SHALL CONSIST OF LOW-LEAD BRASS ALLOY AND SHALL HAVE A MINIMUM WORKING PRESSURE OF 150 PSI.
2. CHLORINATION TAPS SHALL NOT BE LOCATED FURTHER THAN 10 FEET DOWNSTREAM OF THE BEGINNING OF THE NEW MAIN.
3. BOX SHALL BE LOCATED AS INDICATED BY CONTRACT DOCUMENTS OR THE ENGINEER.
4. AFTER DISINFECTION, CLOSE AND CAP CORPORATION STOP AND REMOVE ALL COMPONENTS.

	<b>WATER DEPARTMENT</b>
	CITY OF SANTA CRUZ, CALIFORNIA
<b>DETAIL 22</b>	
<b>CHLORINATION TAP INSTALLATION</b>	
NOT TO SCALE	
APPROVED	RCE 37391

DRAWING No. 2985 A REVISED DECEMBER, 2009  
C:\DOCUMENTS\LOCALS\1\Temp\AcPublish\_3460\DEC2009.dwg

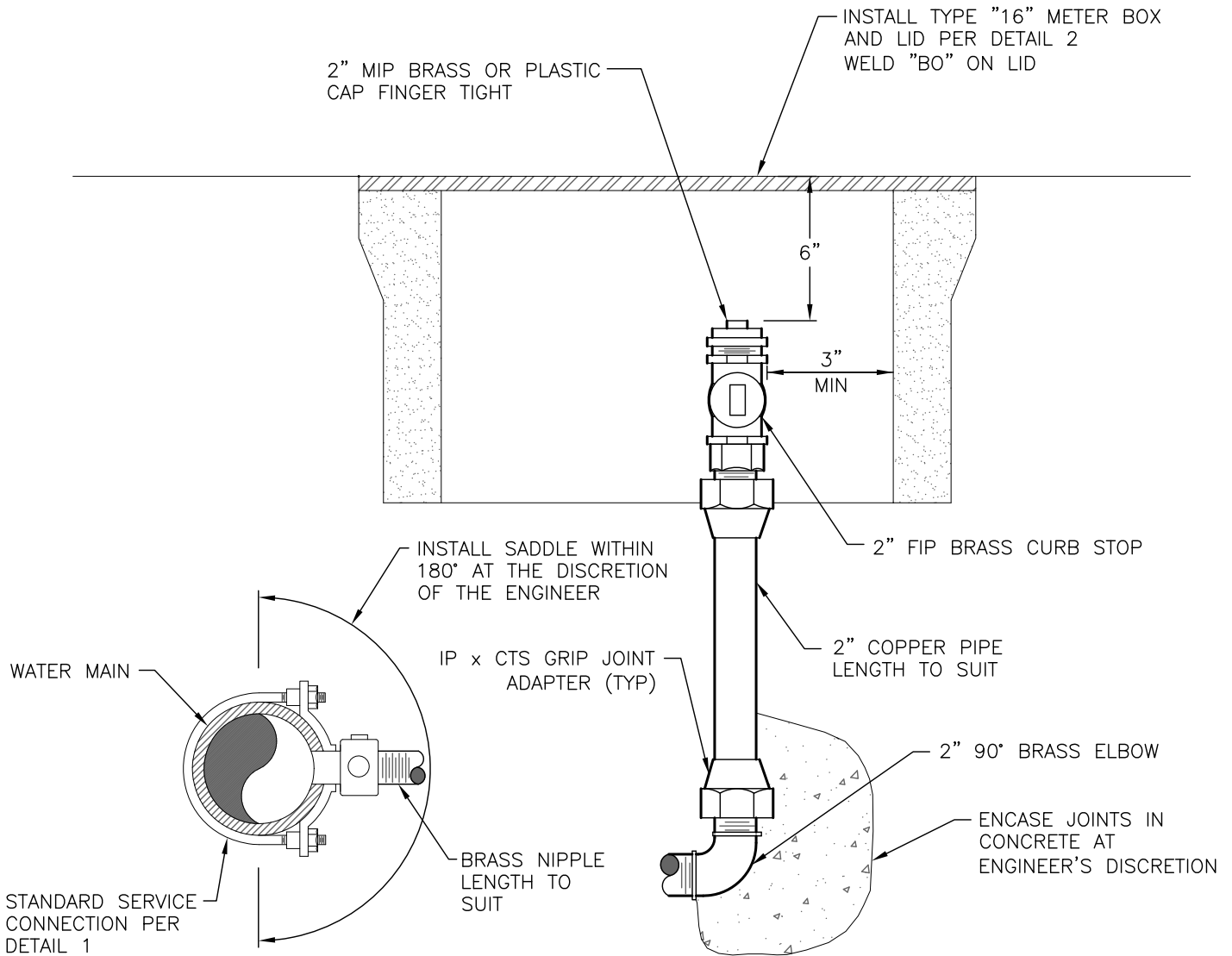

### OFF OF MAIN TAP

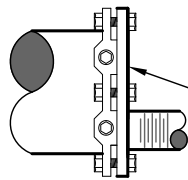

RESTRAINED MJ CAP OR PLUG WITH TAP SIZED FOR BLOW-OFF PIPE  
RESTRAIN JOINTS PER DETAIL 18

### END OF MAIN TAP

#### NOTES

1. BLOW-OFF ASSEMBLY MUST BE RESTRAINED, INCLUDING TEMPORARY INSTALLATIONS.
2. MODIFICATIONS MAY BE PERMITTED AT THE DISCRETION OF THE ENGINEER FOR TEMPORARY INSTALLATIONS.
3. BRASS FITTINGS, VALVES AND PIPE SHALL CONSIST OF LOW-LEAD BRASS ALLOY AND SHALL HAVE A MINIMUM WORKING PRESSURE OF 150 PSI.
4. WRAP ALL FITTINGS & PIPE W/ 2" WIDE, 10-MIL PIPE TAPE WHERE IN CONTACT W/ CONC. THRUST BLOCK

	<b>WATER DEPARTMENT</b> CITY OF SANTA CRUZ, CALIFORNIA
	<b>DETAIL 23</b> <b>BLOW OFF INSTALLATION</b>
NOT TO SCALE	
APPROVED	RCE 37391

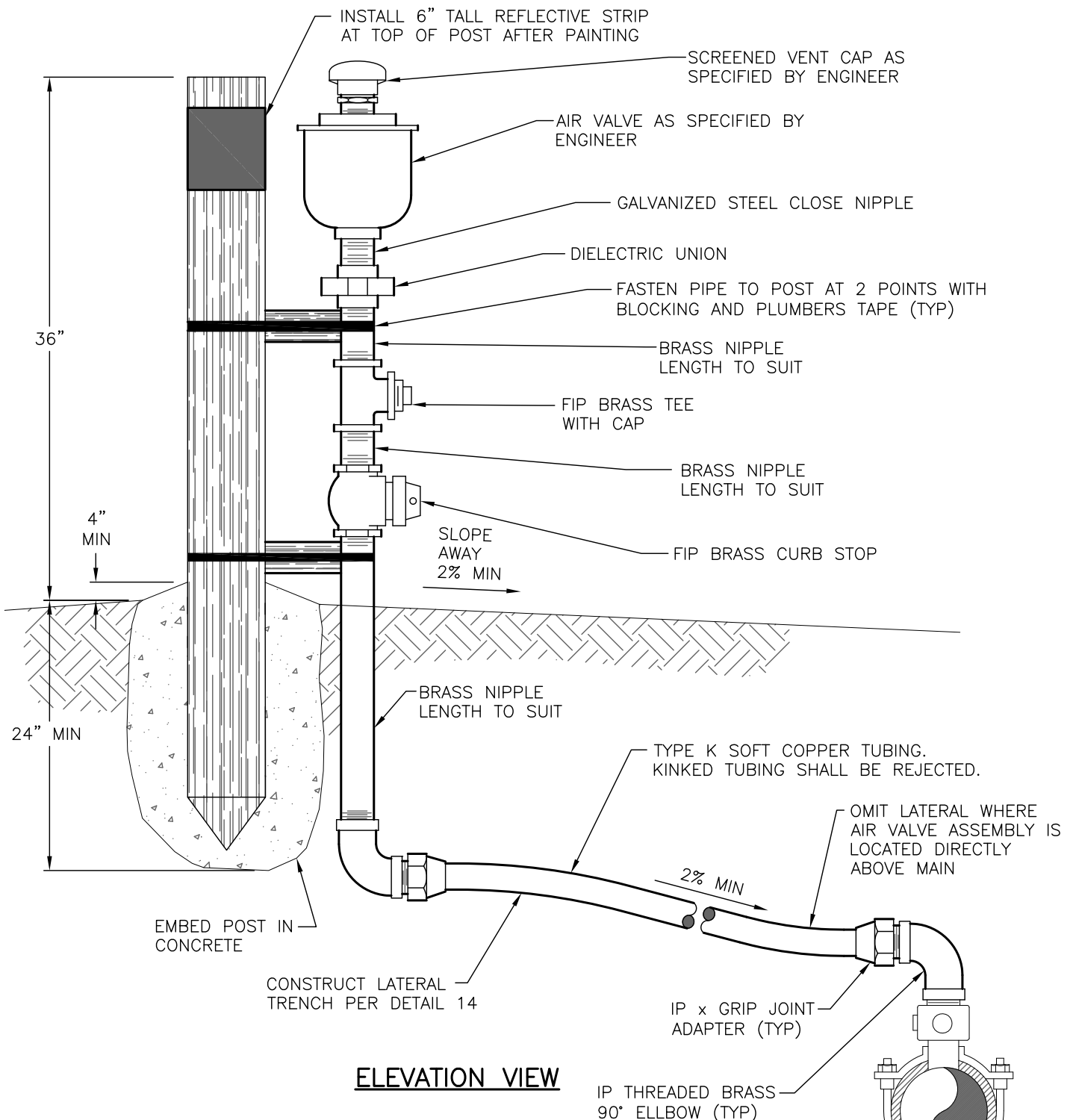

**ELEVATION VIEW**

**NOTES**

1. EXACT LOCATIONS OF TAP AND OF AIR VALVE SHALL BE APPROVED BY THE ENGINEER PRIOR TO INSTALLATION.
2. BRASS FITTINGS, VALVES AND PIPE SHALL CONSIST OF LOW-LEAD BRASS ALLOY AND SHALL HAVE A MINIMUM WORKING PRESSURE OF 150 PSI.
3. AT THE DISCRETION OF THE ENGINEER, A GATE VALVE AND BOX SHALL BE INSTALLED NEAR THE CONNECTION AT THE MAIN PER DETAIL 11.
4. INSTALL LOCKING STEEL ENCLOSURE AND CONCRETE PAD IF REQUIRED BY THE ENGINEER.
5. ABOVE GROUND PIPING, FITTINGS AND ENCLOSURE SHALL BE PAINTED W/ TWO COATS OF RUST PREVENTATIVE ENAMEL.
6. INSTALL TRAFFIC BOLLARD(S) PER DETAIL 20 WHERE REQUIRED BY THE ENGINEER.

STANDARD SERVICE CONNECTION PER DETAIL 1. MAKE TAP AT TOP OF MAIN.

	<b>WATER DEPARTMENT</b>
	CITY OF SANTA CRUZ, CALIFORNIA
<b>DETAIL 24</b>	
<b>AIR VALVE INSTALLATION</b>	
NOT TO SCALE	
APPROVED	RCE 37391

DRAWING No. 2987 A REVISED DECEMBER, 2009 C:\DOCUMENTS\LOCALS\1\Temp\AcPublish\_3460\DEC2009.dwg

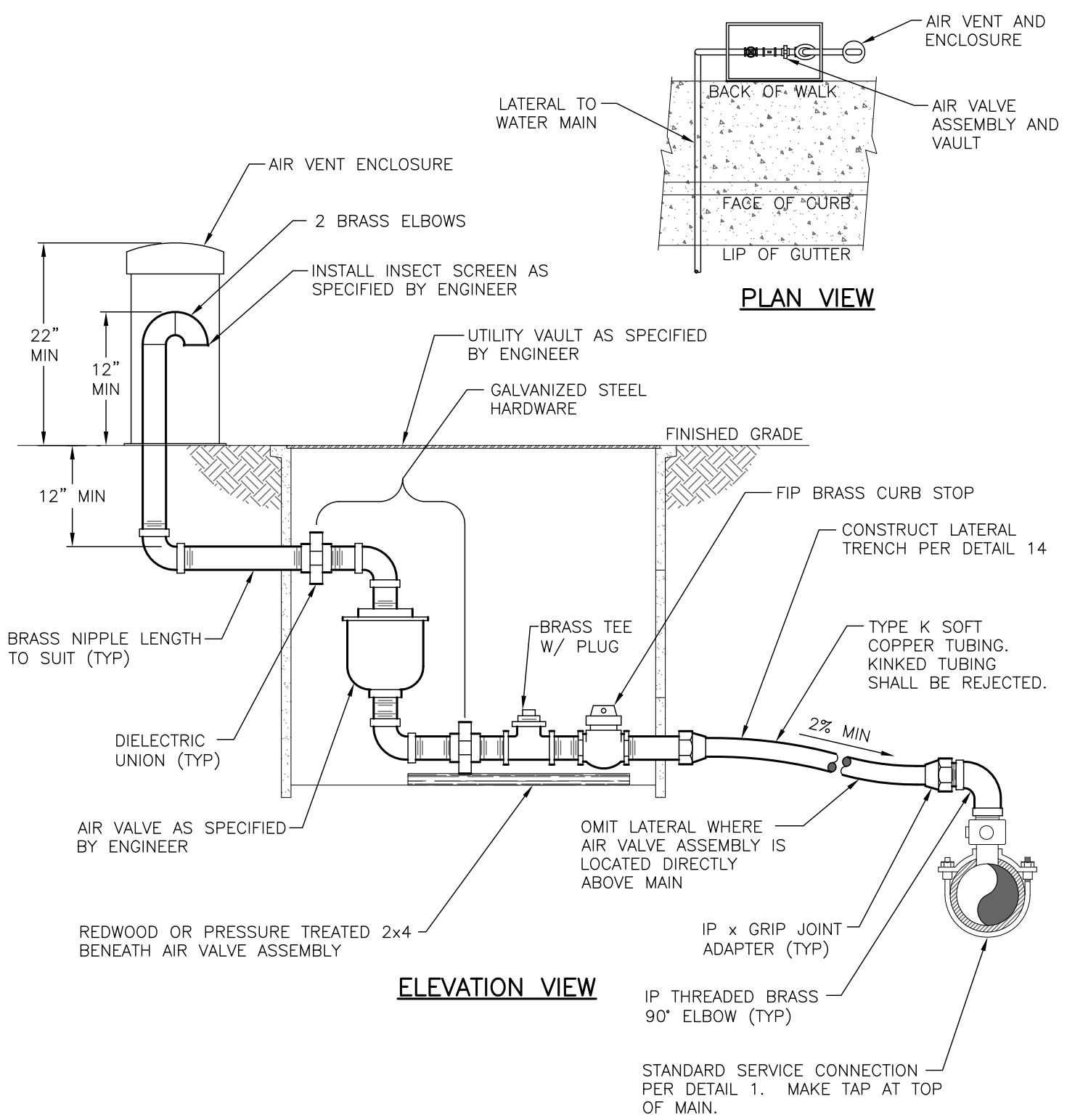

- NOTES**
1. EXACT LOCATIONS OF TAP AND OF AIR VALVE SHALL BE APPROVED BY THE ENGINEER PRIOR TO INSTALLATION.
  2. BRASS FITTINGS, VALVES AND PIPE SHALL CONSIST OF LOW-LEAD BRASS ALLOY AND SHALL HAVE A MINIMUM WORKING PRESSURE OF 150 PSI.
  3. ABOVE GROUND PIPING, FITTINGS AND ENCLOSURE SHALL BE PAINTED W/ TWO COATS OF RUST PREVENTATIVE ENAMEL.
  4. AT THE DISCRETION OF THE ENGINEER, A GATE VALVE AND BOX SHALL BE INSTALLED NEAR THE CONNECTION AT THE MAIN PER DETAIL 11.



**WATER DEPARTMENT**  
CITY OF SANTA CRUZ, CALIFORNIA

**DETAIL 25**

**BELOW GRADE AIR VALVE INSTALLATION**

NOT TO SCALE

*Sanford Wood*

APPROVED \_\_\_\_\_ RCE 37391

DRAWING No. 3720 A REVISED DECEMBER, 2009 C:\DOCUMENTS\LOCALS\1\Temp\AcPublish\3460\DEC2009.dwg