

ENSEMBLE REAL ESTATE INVESTMENTS, LLC  
444 West Ocean Boulevard, Ste 1108  
Long Beach, California, 90802

Attn: Mr. Jason Muller

Subject: Geotechnical Investigation Update I

Reference: Cliff and Bay Mixed Use Development  
190 West Cliff Drive  
Santa Cruz, California

Dear Mr. Muller:

Haro, Kasunich and Associates, Inc. (HKA) has prepared this letter as an update to the Geotechnical Investigation Report for this project prepared by GEOCON, dated 31 March 2017. At the request of Ensemble Real Estate Investments, HKA has accepted the responsibility of Geotechnical Engineer of Record for this project. Although the GEOCON report is thorough it is not compatible with the current project scope. HKA is accepting the GEOCON report in its entirety and has attached a copy of it with this Update Letter. HKA is also introducing some geotechnical related design and construction considerations for the proposed Mixed Use Development at a parking lot, at the northwest corner of West Cliff Drive and Bay Street, Santa Cruz, California. Recommendations presented in this letter supersede those found to be in conflict with the GEOCON report.

In preparation of this Update Letter, HKA had working meetings with Ensemble Real Estate Investments, Cuningham Group the Project Architect, and Bowman and Williams the Project Civil Engineer. HKA also reviewed the following documents:

- 1) Our extensive file pertinent to this project including the Santa Cruz Hotel Expansion at 175 West Cliff Drive, Santa Cruz, California.
- 2) Geologic Study And Preliminary Geotechnical Investigation Coast Hotel, Santa Cruz, California, Prepared by Treadwell & Rollo Environmental and Geotechnical Consultants, dated 29 July 2004.
- 3) Geotechnical Investigation Dream Inn Mixed Use Development Northwest Corner of West Cliff and Bay Street, Santa Cruz, California, Prepared by GEOCON Consultants, dated 31 March 2017.
- 4) Review of Geotechnical Reports By GEOCON and Treadwell-Rollo For Coast Hotel / Dream Inn Mixed Use Development, Prepared by Gary Griggs Engineering Geologist, undated.
- 5) Cliff & Bay Planning Strategy, Prepared by Cuningham Group, dated 8 November 2017.
- 6) Cliff & Bay Preliminary Civil Engineering Plans, Prepared by Bowman & Williams Consulting Civil Engineers, dated 16 November 2017.

### **Site Vicinity and Project Description**

The project site is an approximately flat parcel (Santa Cruz County APN 004-081-12) at the northwest corner of Bay Street and West Cliff Drive in Santa Cruz. The site vicinity is presented in figure 1.

The site is currently an at-grade parking lot with associated areas of landscaping that include large mature trees. Existing development in the near vicinity of the site includes the 10-story Dream Inn Hotel to the east (across West Cliff Drive), 3-story multifamily residential to the south and a mobile home community to the north and west.

Based on review of the Cliff & Bay Planning Strategy, prepared by the CUNINGHAM GROUP, HKA understands the proposed mixed use development to consist of 1 story and 4 story retail and residential use buildings respectively at street level. Below street level a two story parking garage is shown with several access ramps from both Bay Street and West Cliff Drive. The building usage will be a mix of residential units mainly placed in upper floors, commercial units at first floor, parking and building installations at underground floors. According to the project designer information, a 24.0 feet deep excavation from ground surface to top of foundation is required.



Figure 1: Site vicinity

## **Purpose and Scope**

The purpose this Update Letter is to provide more detailed geotechnical related design parameters based on our local experience and the available data at this time. Specifically laboratory and field exploration presented in the GEOCON report and our files pertinent to this project.

We reviewed the recent geotechnical investigation report (2017) provided by GEOCON and find it in general conformance with HKA's local experience in previous investigations at and near the vicinity of the project site. The disadvantage of the GEOCON report is the recommendations that are provided, assume a 13 feet deep excavation. However, based on review of the current architectural drawings, the proposed excavation for the parking

garage is shown to be on the order of 24.0 feet below ground surface. In this letter, we present technical recommendations that are best matched to the studied project regarding local geo-hazard concerns.

Some site-specific design and/or construction problems and concerns that need further engineering consideration to resolve are presented in this letter. HKA will have to work closely with the Project Architect, Project Civil Engineer, and Project Structural Designer to better understand the project specific design challenges as they evolve. Some of these challenges are, but not limited to:

- 1) Temporary shoring and bracing of excavation.
- 2) Dewatering of excavation.
- 3) Rip ability of Purisima Bedrock Formation at planned depths.
- 4) Construction sequencing.
- 5) Drainage and waterproofing of permanent retaining walls.
- 6) Collection and discharge of retaining wall drainage.
- 7) Estimation of lateral surcharge loads from adjacent roadways and buildings.

**Recommendations For Proposed Building Design and Construction Specifications**

According to available geotechnical investigation reports and documents, architectural drawings and the expectations of the designer, geotechnical related recommendations regarding the project requirements are presented below:

**Subsurface layer physical and mechanical property**

1. The physical and mechanical properties of materials encountered in the subsurface layers have been evaluated using SPT test blowcounts, laboratory analyses, soil sample observation and engineering judgment. These properties are presented in table 1.

Table 1: Subsurface layers physical and mechanical property

Parameter \ Layer Type (Description, #)	Medium Dense Silty / Clayey SAND Coastal Terrace (0 ft to 13.5 ft)	Highly weathered & Fractured Purisima Bedrock (Fine silty SAND or Sandy SILT) (13.5 ft to 30 ft)
Friction Angle (deg)	30-32	40-45
Cohesion (psf)	0-200	500-900
Unit Weight (pcf)	110-120	115-125
Poisson's Ratio	0.3	0.3
Modulus of Elasticity (ksf)	400-600	1,200-1,800

## **Shallow Foundations**

2. Allowable bearing capacity, settlement and subgrade reaction modulus for square, strip footings with length to width (L/B) ratio of 2 & 10 and mat foundation has been calculated and are presented in Figures 1 to 4 of Appendix A. For conventional spread square and strip foundation the estimated total and differential settlement is limited to one (1) inch and 0.5 inch respectively. Mat foundations reduce differential settlement between the walls or columns which are placed on them. Therefore, greater allowable total settlements of about three inches can be used as a limiting value. For example, the bearing capacity for 3 inch settlement of the project mat foundation with 173 feet by 276 feet dimension is 6.20 ksf and subgrade reaction modulus is 26 kcf. Bearing capacity and subgrade reaction for 4-foot wide square foundation is 12.9 ksf and 676 kcf respectively.
  
3. According to architectural drawings provided by CUNINGHAM GROUP, the elevation at the top of the foundation is shown to be 24.0 feet below the ground surface (bgs). In our calculations, the excavation depth is assumed 24.0 feet bgs. The embedment depth for square and strip foundation is assumed to be a minimum two feet deep. Mat foundations which will be placed at the base of the excavation will have bottom of slab at 24.0 feet bgs.

4. Shear failure of the soil underneath the foundation and its settlements were assessed simultaneously in order to determine the allowable soil pressure. Due to the type of the subsurface layers which are sand, foundation settlements consist of immediate elastic settlement.
5. As a first estimate, the maximum amount of unequal settlement for a fully flexible foundation is 1/2 of its total settlement. The exact value is related to the stiffness of the foundation and the soil underneath it.
6. In the case of short term loading, such as wind or earthquake, the allowable bearing capacity of soil can be increased by 33%.

#### **Drilled Pier Foundation and Soldier Pile (Temporary Shoring)**

7. Drilled pier foundations are recommended where the structural designer determines deep foundation should be used to resist lateral overturning forces or concentrated axial loads. These foundation elements can be used in conjunction with shallow foundations. Drilled piers are also anticipated for foundation support of the temporary shoring that will be needed to support the cut slopes of the planned excavation of the project site.



8. End bearing drilled pier foundations below the bottom of excavation can use an allowable bearing capacity of 10,000 pounds per square foot. The pier should always have to minimum 2 feet embedded into the Purisima Bedrock Formation.

9. The soldier pile wall should be designed to resist drained or undrained active earth pressures, seismic surcharge, and surcharge from adjacent dead and live loads within the influence from the back of wall.

10. To minimize potential for movement of adjacent improvements including heavily traveled roadways and neighboring residential buildings the soldier pile retaining wall should be carefully built using top down construction techniques. If careful top down shoring construction sequencing is implemented during excavation of the parking garage there is very little to no chance for impact to adjacent properties.

11. Soldier piles should have a minimum pier shaft diameter of 18 inches and minimum horizontal spacing of 4 feet measured center to center on the steel member.

12. The actual depths of the pier portion of the soldier pile should be embedded following the shoring designer.

13. The top one (1) foot of the soldier pile should be neglected for calculating passive resistance. The portion of the soldier pile below the planned excavation is anticipated to be embedded into Purisima Bedrock Formation, a passive lateral earth pressure with an equivalent fluid weight of 550 pcf acting over 2.8 pier diameters should be used. This assumes a drained static loading condition and a factor of safety equal to 1.0. If pier spacing is planned to be less than 2 pier diameters measured on center HKA should be contacted to determine the reduced passive as a result of overlap.

14. The soldier pile wall should be designed to resist active and surcharge pressures in accordance with the section of this report titled Active and Passive Pressure.

15. The pier shafts may require hand digging and continuous casing depending on site conditions and restraints.

16. Wood lagging should be spaced to allow for weeping of drainage from behind the wall.

17. Contractor is responsible for following CAL-OSHA regulations and those outlined on project plans sheets to maintain a safe working environment at the project site.

18. The steel soldier pile member should extend the full depth of the excavation to a point 3 inches above the bottom of the cased shaft.

19. The soldier piles may consist of steel H-beams inside a drilled and cast-in-place concrete pile. Structural concrete should be used below the bottom of the excavation and lean concrete above, so the concrete can be chipped out to place the lagging.

### **Active and Passive Pressures**

20. The active pressures as an equivalent fluid pressure for both undrained and drained conditions without considering neighboring building surcharge or street surcharges due to vehicles pressure and for static and seismic conditions are presented in table 2. It must be noted that the effect of neighboring surcharges especially the pressure from the 10-story hotel building on the soil behind the temporary shoring must be determined considering the hotel foundation type, dimension and elevation and the distance from the hotel to the sides of the subject excavation. It also should be noted that, based on different soil properties, active and passive pressure quantities are different in Terrace Deposits than in Purisima Bedrock Formation. If understood correctly, the project plans shown an excavation of the site soil down to about 24.0 feet bgs. The planned excavation will encounter both Terrace Deposits and Purisima Bedrock Formation. Different lateral pressures will be applied on temporary shoring systems based on the subsurface soil properties encountered.

**Table 2: Recommended active pressures**

Recommended Active Pressure EFW (pcf)	Terrace Deposit (0' – 13.5')	Purisima (13.5' – 30')
Undrained / Static condition	79	75
Undrained / Seismic condition	90	83
Drained / Static condition	37	25
Drained / Seismic condition	61	44

21. The passive pressure available in the soils below the bottom of the excavation may be presented as an equivalent fluid pressure:

**Table 3: Recommended passive pressures**

Recommended Passive Pressure EFW (pcf)	Terrace Deposit (0' – 13.5')	Purisima (13.5' – 30')
Undrained / Static condition	220	350
Undrained / Seismic condition	200	300
Drained / Static condition	350	600
Drained / Seismic condition	300	500

To account for the rounded shapes of the soldier piles, when calculating the passive pressure on individual piles assume the equivalent fluid pressure may be multiplied by a recommended factor of 2 times pier diameter for the Terrace Deposits and 2.8 times the pier diameter for the Purisima Bedrock Formation.

**Site-specific technical concerns that requires further engineering investigation**

Based on project location, subsurface soil properties, excavation depth and other proposed building specifications, several site-specific concerns include but are not limited

to, are presented in this section that requires further geotechnical engineering evaluation prior to construction.

### **Excavation Support Methods**

Excavation support systems are used to minimize the excavation area, to keep the sides of deep excavation stable, and to ensure that movements will not cause damage to neighboring structures or to utilities in the surrounding ground. Some of the conventional methods for excavation support is describe here briefly:

#### **1- Solider Beam and Lagging**

Soldier piles or soldier beams are H-piling drilled or driven at regular intervals along the planned excavation perimeter. Predrilling as opposed to driving is used to provide close control of alignment and location. Predrilling also minimizes the noise and other nuisance to neighboring properties related to pile driving activities. These piles are then grouted in place with lean concrete. Lagging consisting of wood, steel or precast concrete panels is inserted behind the front pile flanges as the excavation continues. Additionally, contact lagging or shotcrete may be applied. The lagging efficiently resists the load of the retained soil and transfers it to the piles. Soldier beams are installed to a depth below the final excavation. Drilled holes can be filled with pea gravel, slurry, concrete, or similar material. Normally wall is constructed in a controlled top down manner.

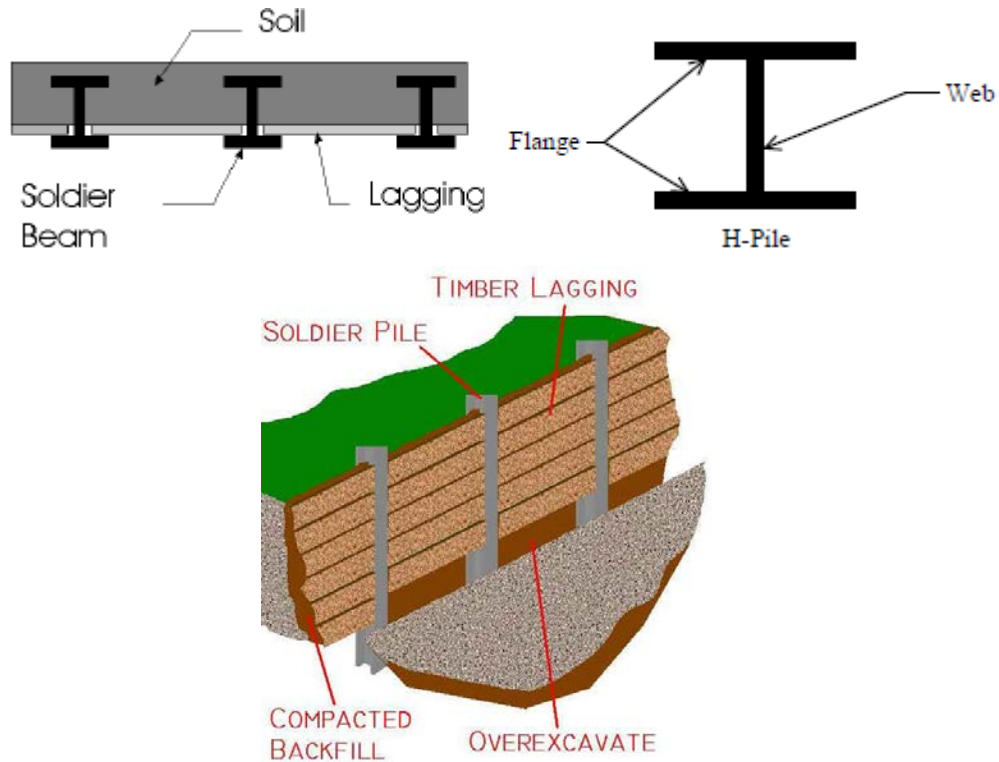

Figure 2: Soldier pile and lagging system

## 2- Solider Beam and Lagging

Soldier beam can be combined with internal bracing elements. The bracings are supported by spread footing located at the bottom of the excavation and embedded into soil. The central portion of the work area is relatively uncluttered. Horizontal lagging system should be used between each bracing set. Usually, the remained soil below the oblique bracing elements should be excavated manually. Especially for our project which the subsurface layers consist of about 13 feet thick terrace deposits laid over Purisima Formation bed rock, in order to minimize disturbing the bed rock, the soil layer under the rakers should not be excavated by drilling rigs, loaders, bulldozers or any vibratory and

rough equipment. The remained bed rock will be removed manually at appropriate time after whole safety procedures are furnished.

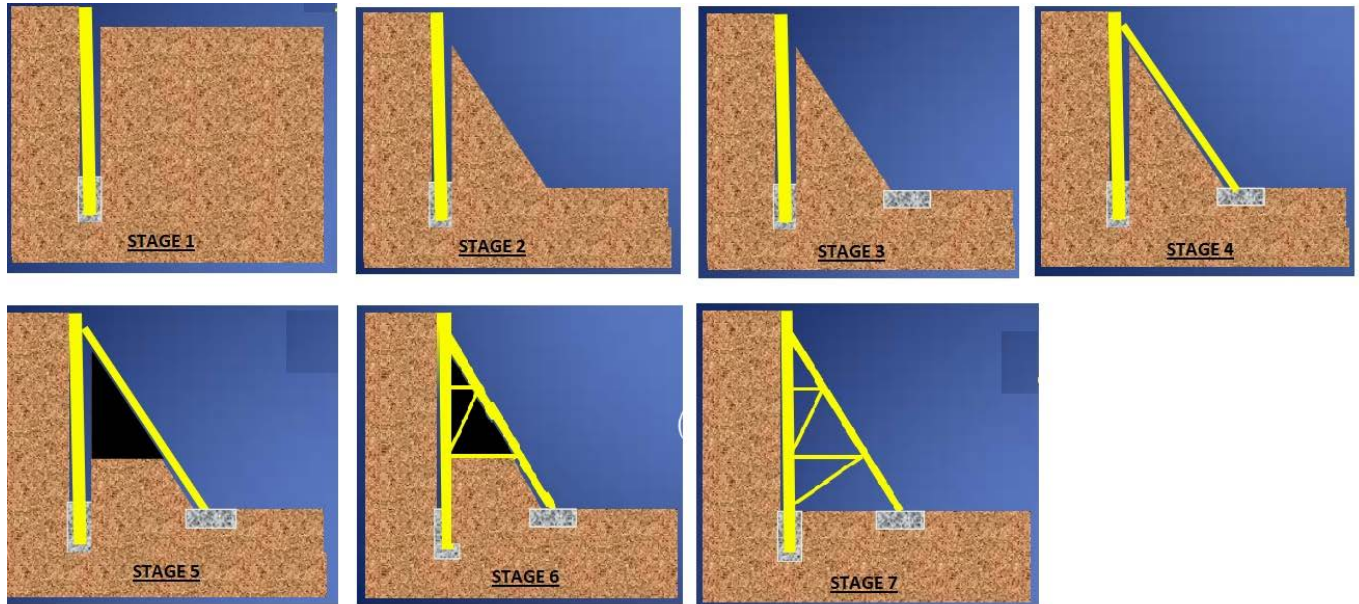

Figure 3: Excavation sequence using soldier pile and bracing system

### 3- Secant Pile / Tangent Pile / Pin Pile

Second pile walls are formed by constructing intersecting piles. Secant bored pile walls are formed by keeping spacing of piles less than one diameter. Secant pile walls are used to build cut off walls for the control of ground water inflow and to minimize movement in weak and wet soils. Secant wall constructed in the form of hard/soft or hard/firm walls. If the distance between the hard and soft piles are equal to piles diameter, the wall is called tangent pile wall or pin pile wall. If the distance is more than pile diameter but less than distance that soil arching is provided and no lagging is required, the system is called pin

pile wall. The columns are constructed using soil mixing, jet grouting or drilled shaft methods. The design can incorporate steel bar or beams for reinforcement to provide additional lateral support. Secant, tangent or pin pile walls can be constructed in a wide variety of soil conditions.

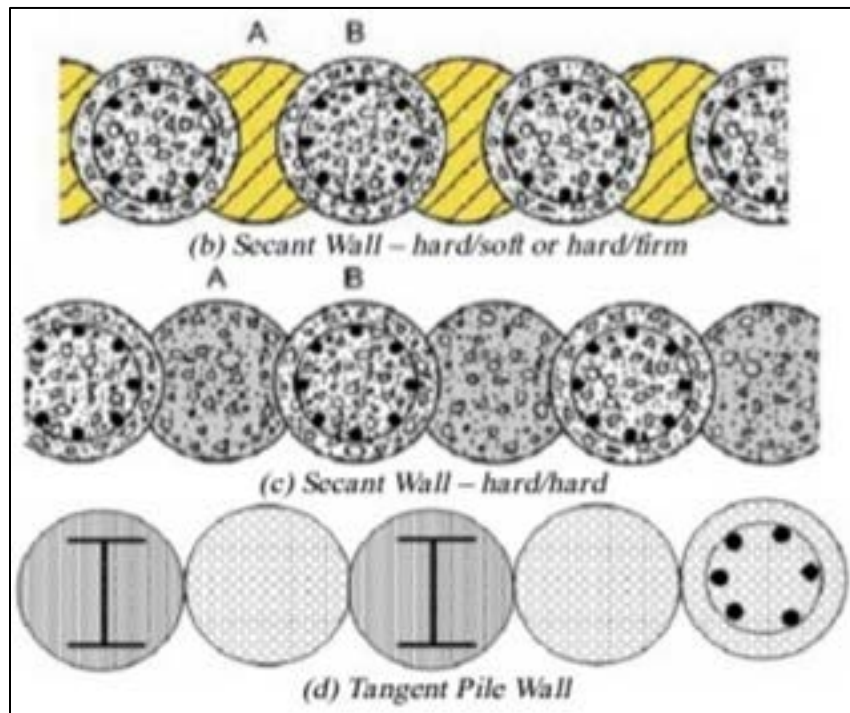

Figure 4: Secant pile wall / Tangent pile wall

#### 4- Deep Soil Mixing

Wet soil mixing is also known as the Deep Mixing Method. A powerful drill advances a mixing tool as binder slurry is pumped through the connecting drill steel, mixing the soil to the target depth. Common Uses of these method include Increase in bearing capacity and decrease settlement, mitigate liquefaction, provide structural support and reduce



lateral loads and increase global stability. This process constructs individual soil-crete columns, rows of overlapping columns or complete mass stabilization. Wet soil mixing is used in nearly any soil type, including organics. If the moisture content is greater than 60%, dry soil mixing may be more economical.

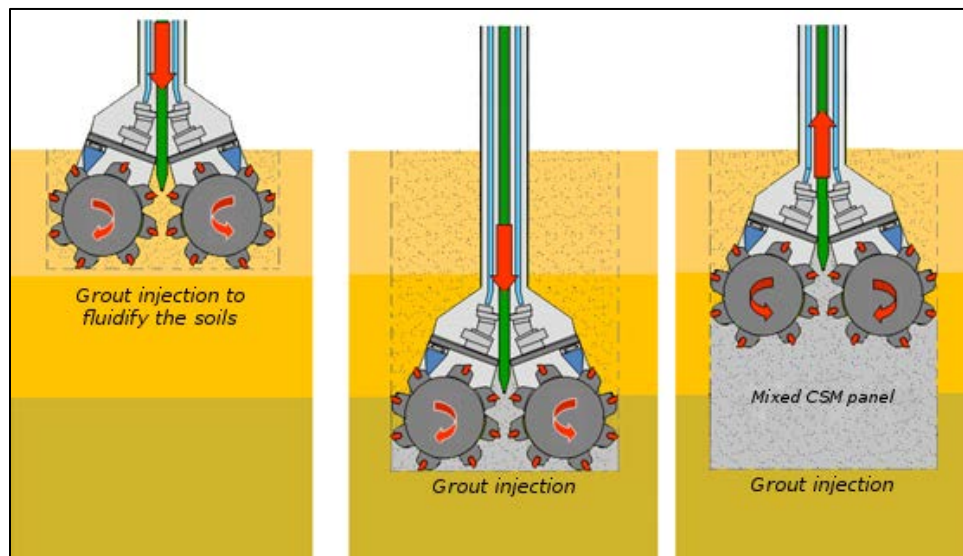

Figure 5: Deep soil mix column

In order to design excavation temporary shoring system with one of the methods mentioned above, it would be prudent to consider the surcharge effects on the project excavation. The 10-story dream Inn Hotel at east of the property is 97 horizontal feet away at its closest point from the proposed excavation. There is very little to no chance that the foundation for the hotel will have influence on the shoring system and vice versa. The Dynamic surcharges of vehicles on adjacent Bay and West Cliff streets should also be considered as part of shoring design. The adjacent streets are likely to have influence on

the shoring system and vice versa. As stated in a previous section if careful top down shoring construction sequencing is followed there would be very little to no chance the parking garage excavation would have any impact to the adjacent streets.

### **Rip Ability**

Environmental and safety concerns have made production ripping a popular method of excavating bedrock formations. Modern tractors advanced ripping capabilities by mounting the ripper to the rear of the machine. However some materials or formations can be ripped easier than others.

Sedimentary rocks, such as the local Purisima Bedrock Formation at the project site, consist of material derived from destruction of previously existing rocks. Water action is responsible for the largest percentage of sedimentary rocks, although some result from wind or glacial pressure. Their most prominent feature is stratification. This family of rocks is generally the most easily ripped. Little or no trouble is encountered with hardpan, clays, shales or sandstones. Likewise, any highly stratified or laminated rocks and formations with extensive fracturing offer good possibilities for ripping.

According to our local experience, the Purisima Formation at the project site, and within the planned depth of the parking garage is rippable and/or can be drilled using conventional construction equipment such as an excavator and backhoe. Where the

Purisima Formation becomes less weathered and shiny blue in color (typically 15 to 20 feet into the formation) similar but just heavier versions of the equipment, may be needed.

### **Drainage Design Consideration**

Surface water runoff and groundwater can cause difficulties during construction, increase the cost and duration of construction, impair long-term integrity, and weaken the performance of excavation walls. These complications can be mitigated if surface water runoff and groundwater is controlled both during and after construction of the retaining wall. Additionally, it has been shown that retaining walls perform significantly better when an effective drainage system is installed to control water levels behind the wall. A brief description of the control systems commonly used is presented below.

### **Surface and perched Water Control**

Dewatering measures during construction include, as a minimum, the control of surface water runoff and subsurface flow associated with either perched water or localized seepage areas. A surface water interceptor ditch, excavated along the crest of the excavation with a controlled discharge point, is a recommended element for controlling surface water flows from cascading over the top edge of the excavation. In figure 7, schematic drawing of concrete ditch is shown.

### Long-Term Groundwater and Surface Water Control

*Geocomposite Drain Strips:* These elements are strips of synthetic material approximately 300 to 400 mm (12 to 16 in.) wide. They are placed in vertical strips against the excavation face along the entire depth of the wall (figure 7). The horizontal spacing is generally between 5 ft to 10 ft. The lower end of the strips discharges into a pipe drain that runs along the base of the wall or through weep holes at the bottom of the wall.

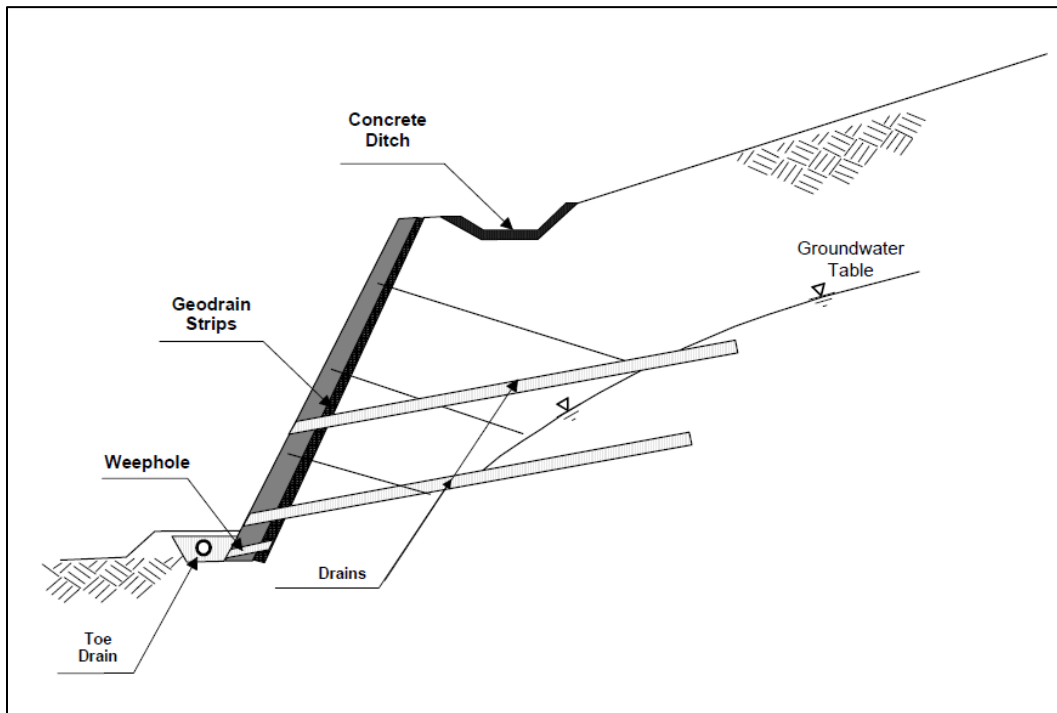

Figure 6: Different drainage systems to control perched and run off water

*Shallow Drains (Weep Holes):* These are typically 12 in to 16 in long, 2 in to 4 in diameter PVC pipes discharging through the face and located where localized seepage is

encountered or anticipated. Weep holes are also used as the terminating point of the vertical strip drains to allow any collected water to pass through the wall.

*Drain Pipes:* Horizontal or slightly inclined drain pipes may be installed where it is necessary to control the groundwater pressures imposed on the retained soil mass. Drain pipes typically consist of 2 inch diameter PVC slotted or perforated tubes, inclined upward at 5 to 10 degrees to the horizontal. Drain pipes are typically longer than the length of the tiebacks and serve to prevent groundwater from being in contact with the tiebacks or the tieback-wall mass, as shown in Figure 10. They are installed at a density of approximately one drain per 100 square ft of wall face. The PVC pipe should be slotted.

## **Conclusion**

In closing the planned project is feasible from a geotechnical engineering standpoint so long as the recommendations of this document are carefully followed during preparation of project plans and during construction. Geotechnical considerations for this project include uniform support of foundations, excavation of parking garage, surcharge against shoring from adjacent streets, careful construction sequencing during top down shoring, perched groundwater over the bedrock, rip ability of bedrock. If our recommendations are correctly implemented there is very little to no chance for the planned improvements to have impact on neighboring properties and their improvements.

Bay and Cliff Mixed Use Development  
Project No. M11374  
Santa Cruz, California  
20 November 2018  
Revised 14 February 2018  
Page 22

If you have any questions concerning our conclusions or recommendations, presented in this report please contact our office.

Respectfully submitted,

**HARO, KASUNICH & ASSOCIATES, INC.**

Moses E. Cuprill, P.E.  
C.E. 78904



KY/MC/mc  
Attachments

Copies : 4 to addressee

- 1 PDF Copies Jason Muller [jmuller@ensemble.net](mailto:jmuller@ensemble.net),
- 1 PDF Copies Marcy Schulte [mschulte@cunningham.com](mailto:mschulte@cunningham.com),
- 1 PDF Copies Juan Perez [jperez@cunningham.com](mailto:jperez@cunningham.com),
- 1 PDF Copies 'Joel Ricca' [joel@bowmanandwilliams.com](mailto:joel@bowmanandwilliams.com),

Bay and Cliff Mixed Use Development  
Project No. M11374  
Santa Cruz, California  
20 November 2018  
Revised 14 February 2018  
Page 23

## Appendix A

Allowable Bearing Capacity, Settlement and Subgrade Reaction Modulus  
for Square, Strip and Mat Foundations

## Allowable Bearing Capacity & Settlement for Square and Strip Footings

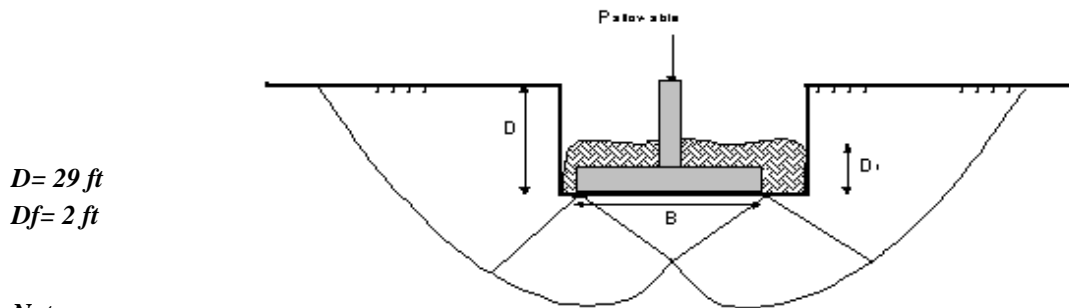
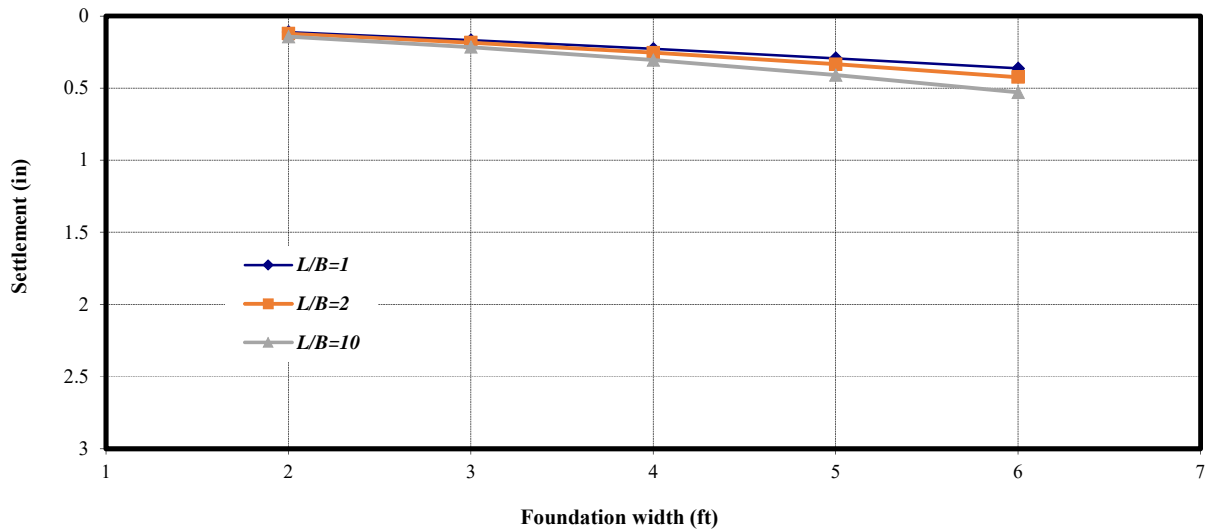
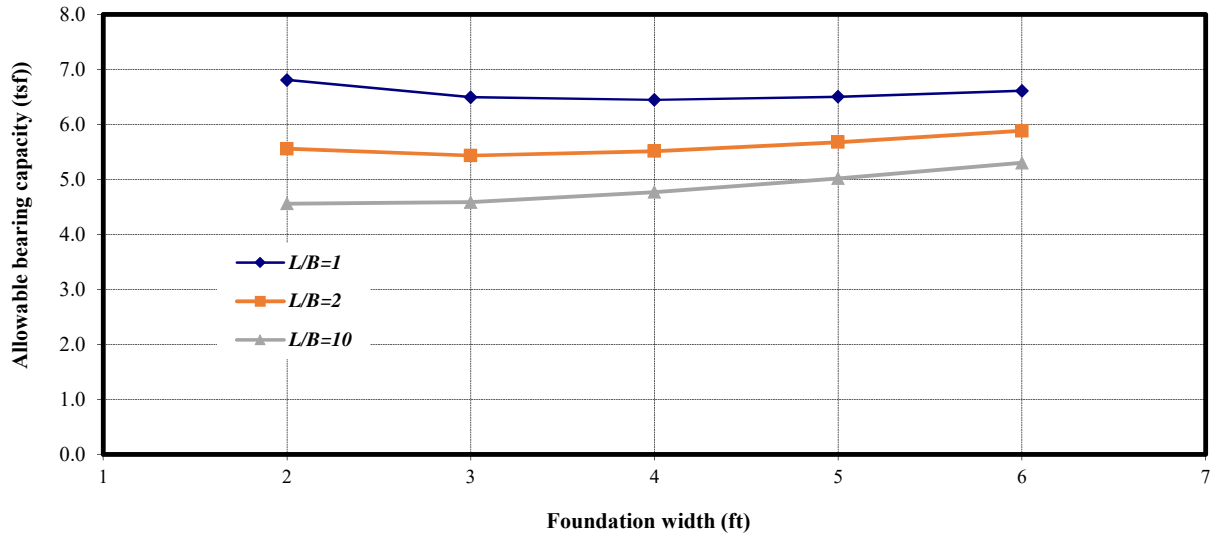

$D = 29 \text{ ft}$   
 $D_f = 2 \text{ ft}$

**Notes:**  
 $D$  : Depth of footing with respect to ground surface  
 $D_f$  : Depth of footing embedment

Allowable Settlement = 1 inch



## Subgrade Reaction for Square and Strip Footings

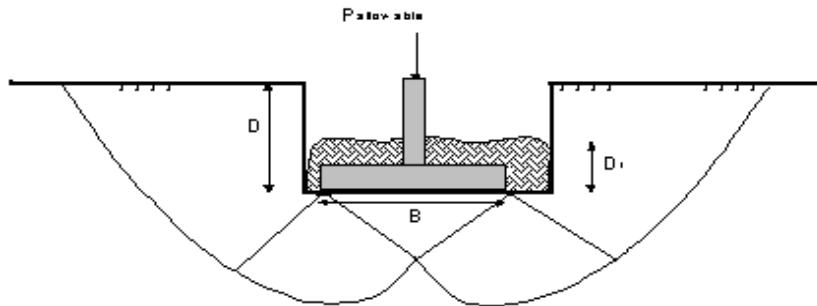
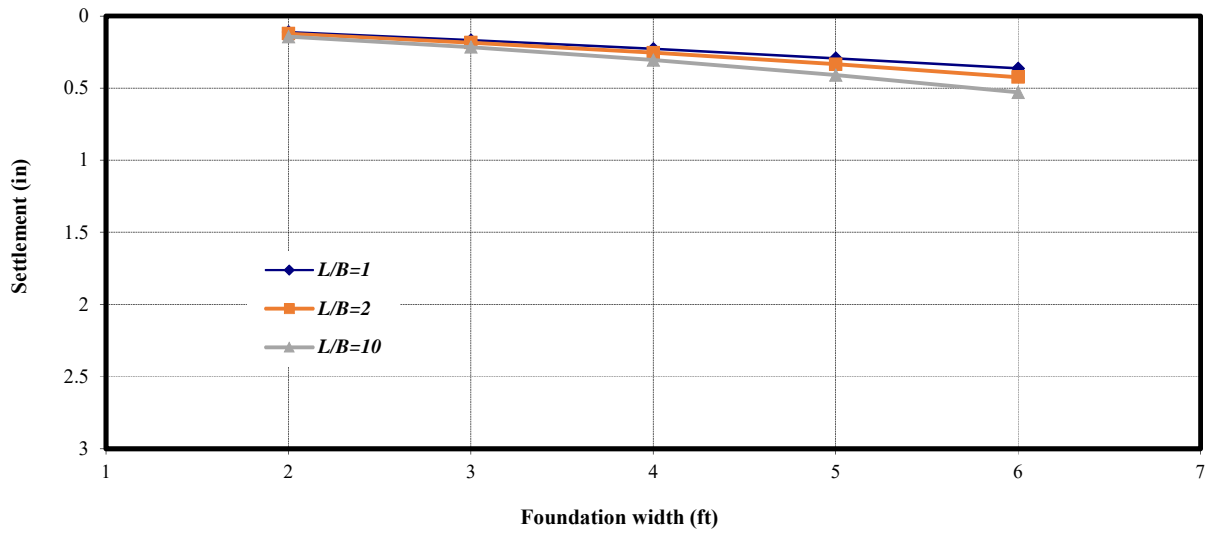
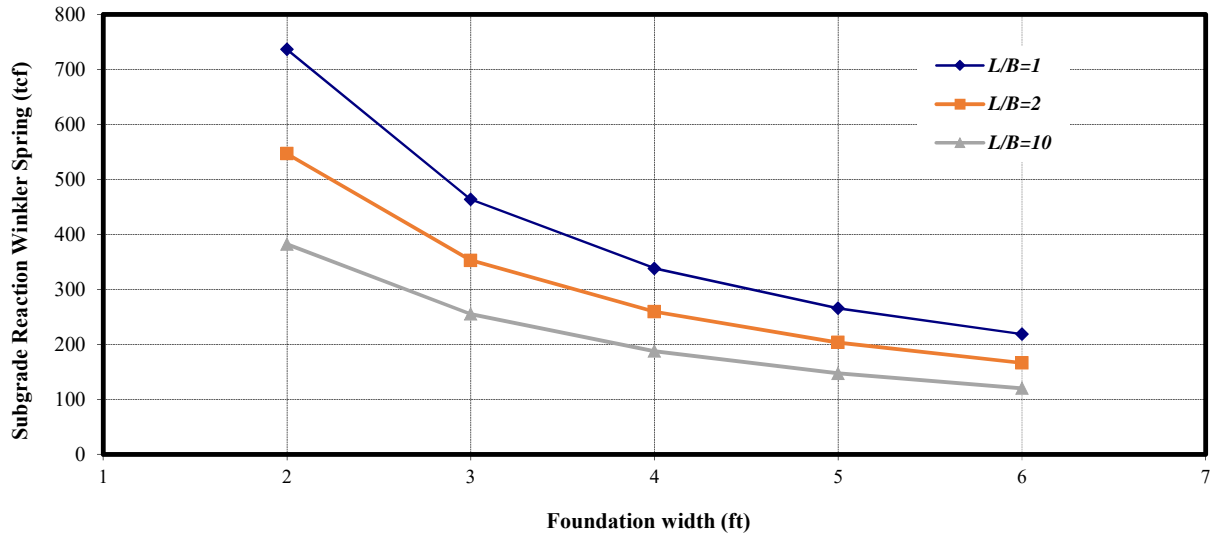

$D = 29 \text{ ft}$   
 $D_f = 2 \text{ ft}$

**Notes:**  
 $D$  : Depth of footing with respect to ground surface  
 $D_f$  : Depth of footing embedment

Allowable Settlement = 1 inch

**Allowable bearing capacity for Mat Foundation**

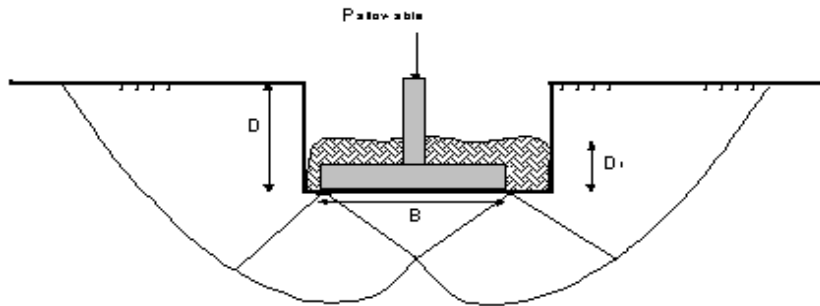
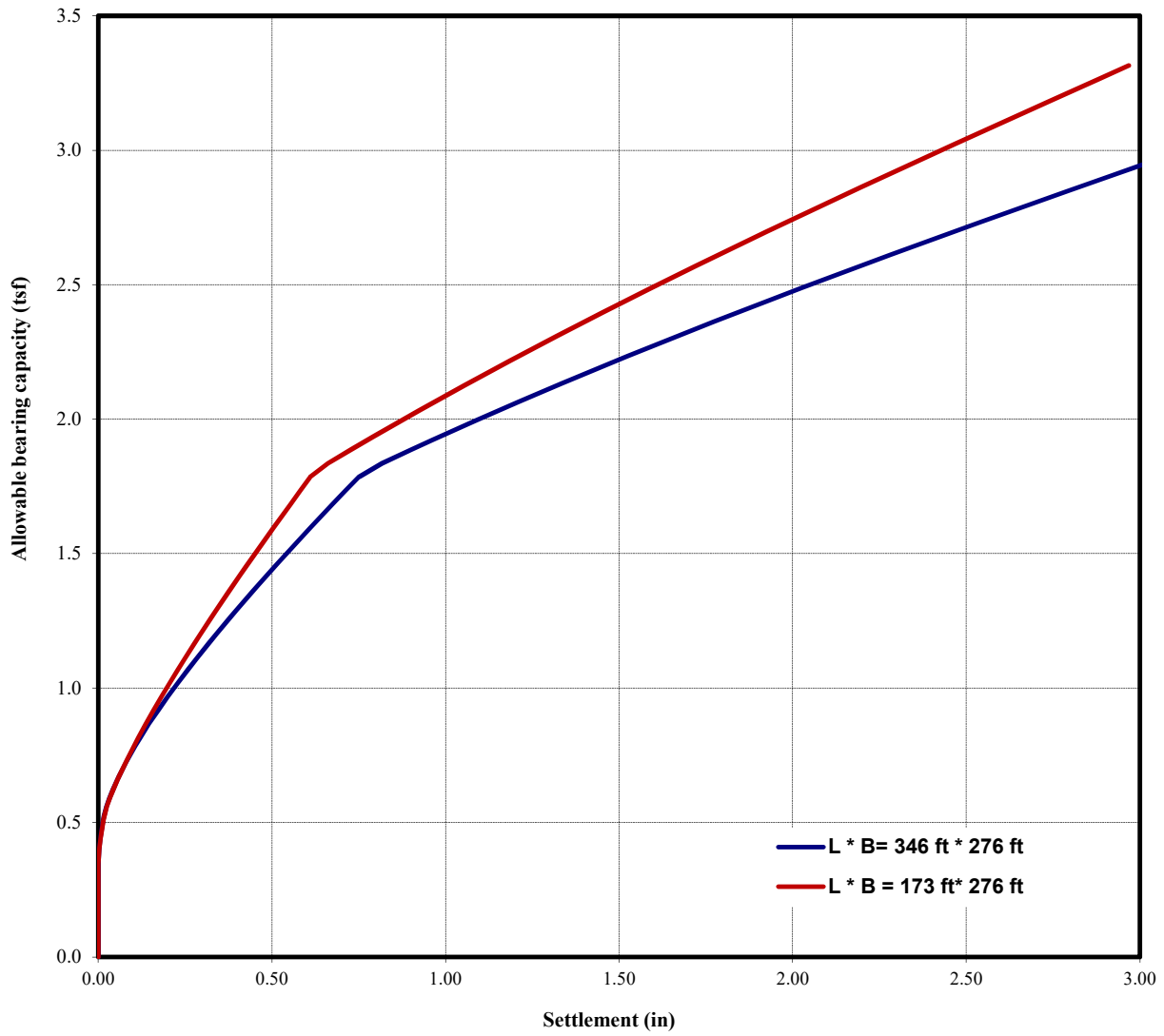

*D = 29 ft*  
*Df = 29 ft*

**Notes:**  
*D : Depth of footing with respect to ground surface*  
*Df : Depth of footing embedment*

*Allowable settlement = 2 inches*

# Mat Foundation

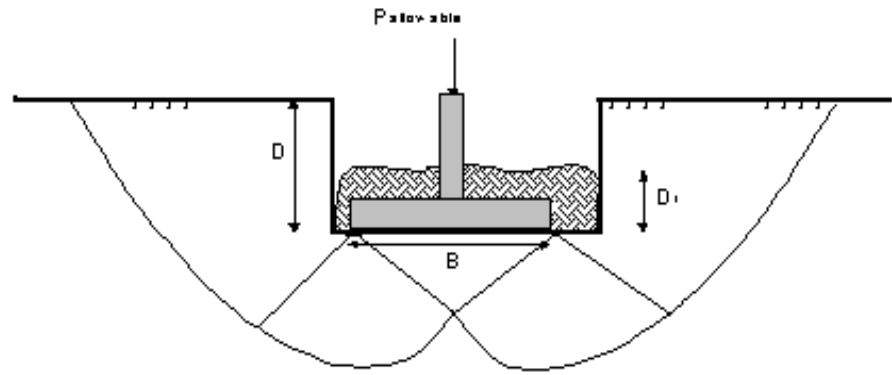
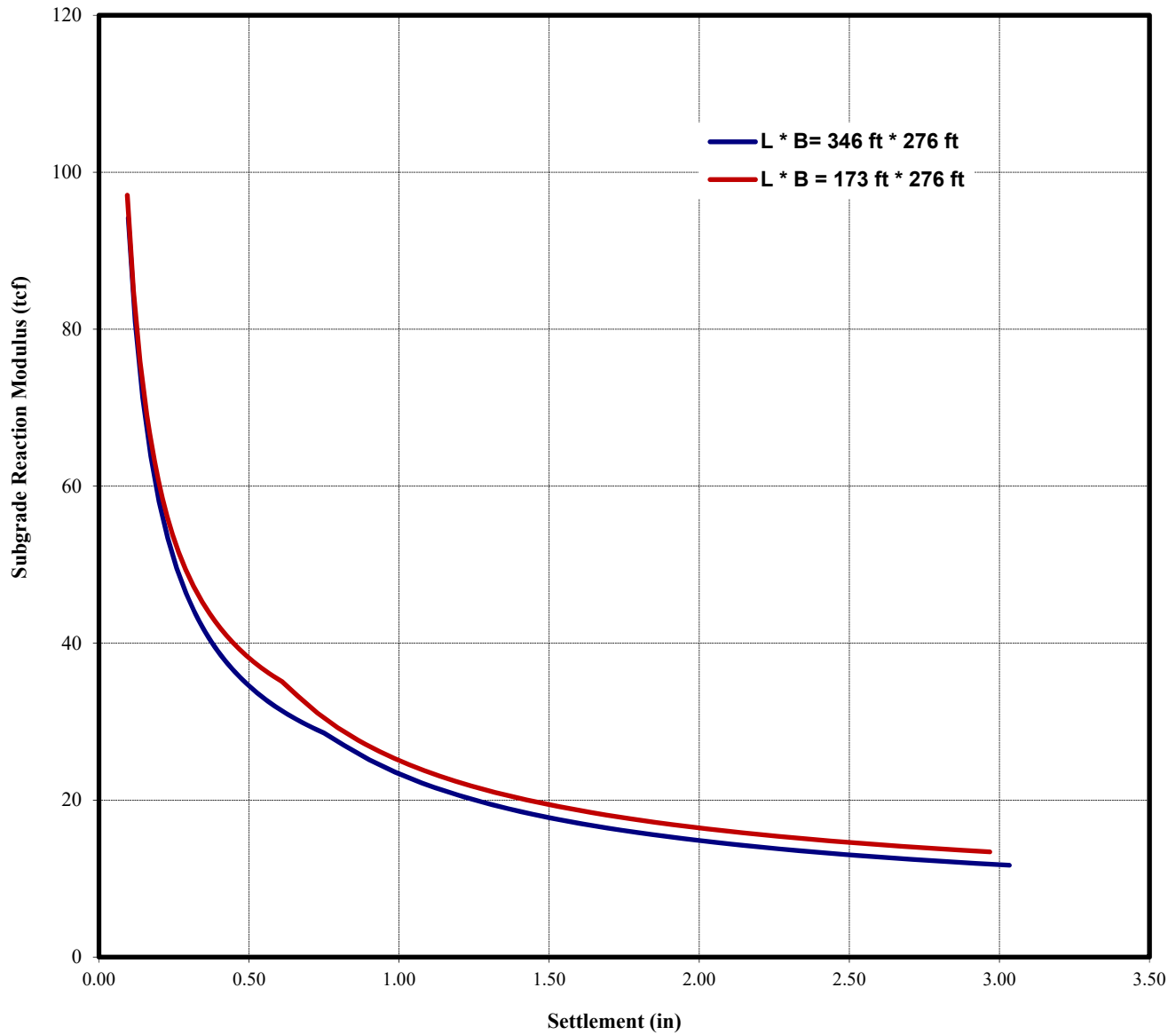

*D = 29 ft*  
*Df = 29 ft*

*Notes:*  
*D : Depth of footing with respect to ground surface*  
*Df : Depth of footing embedment*

Bay and Cliff Mixed Use Development  
Project No. M11374  
Santa Cruz, California  
20 November 2018  
Revised 14 February 2018  
Page 24

## Appendix B

Santa Cruz County Soil Engineer Transfer of Responsibility Form

GEOCON Geotechnical Investigation Dated 31 March 2017



# COUNTY OF SANTA CRUZ

## PLANNING DEPARTMENT

701 OCEAN STREET, 4<sup>TH</sup> FLOOR, SANTA CRUZ, CA 95060  
(831) 454-2580 FAX: (831) 454-2131 TDD: (831) 454-2123  
KATHLEEN MOLLOY PREVISICH, PLANNING DIRECTOR

### SOILS ENGINEER TRANSFER OF RESPONSIBILITY

APN: 004 - 081 - 12

DATE: 20 November 2017

OWNER: Ensemble Real Estate Investment

PROJECT LOCATION: 190 West Cliff Drive Santa Cruz

#### PROJECT DESCRIPTION:

Mixed use development including 4 story residential with first level retail and two story subterranean parking structure.

Our firm is taking over the above referenced project as the project soils engineer of record.

We have reviewed the original geotechnical work for this project. Completed work reviewed to date is as follows (detail all reports including author, title, date and project number):

Geotechnical Investigation Prepared by GEOCON Consulting Engineers dated 31 March 2017

Based upon our review, we offer our professional opinions as follows (check where applicable):

We concur with all of the technical conclusions and recommendations.

We do not agree with or support geotechnical conclusions or recommendations as detailed on the attached report (attach new conclusions and recommendations and all new supporting data and reasoning).

*Please read prior to signature*

*By signing below, we agree to accept responsibility within our area of technical competence for approval of this project upon completion of the work.*

SIGNED: \_\_\_\_\_

(Apply California State-registered civil or soils engineer's signature and wet stamp here)

RETURN TO: \_\_\_\_\_





# GEOTECHNICAL INVESTIGATION

**Dream Inn Mixed Use Development  
Northwest Corner of  
West Cliff Drive & Bay Street  
Santa Cruz, California**

***PREPARED FOR:***

**ENSEMBLE REAL ESTATE INVESTMENTS  
444 W. OCEAN BOULEVARD, SUITE 1108  
LONG BEACH, CALIFORNIA 90802**

**ENSEMBLE<sup>®</sup>**  
REAL ESTATE INVESTMENTS

***PREPARED BY:***

**GEOCON CONSULTANTS, INC.  
6671 BRISA STREET  
LIVERMORE, CALIFORNIA 94550**

  
**GEOCON**

**GEOCON PROJECT NO. E8978-04-01**

**MARCH 2017**



Project No. E8978-04-01  
March 31, 2017

Ensemble Investments, LLC  
444 W. Ocean Boulevard, Suite 1108  
Long Beach, California 90802

Attention: Mr. Jason Muller

Subject: DREAM INN MIXED-USE DEVELOPMENT  
NORTHWEST CORNER OF WEST CLIFF DRIVE AND BAY STREET  
SANTA CRUZ, CALIFORNIA  
GEOTECHNICAL INVESTIGATION

Dear Mr. Muller:

In accordance with your authorization of our proposal dated February 7, 2017, we have performed a geotechnical investigation for the subject mixed-use project in Santa Cruz, California. Our investigation was performed to observe the soil and geologic conditions that may impact site development and construction for the project as presently planned. The accompanying report presents the results of our investigation and conclusions and recommendations pertaining to the geotechnical aspects of the proposed project. The findings of this study indicate the site is suitable for development as planned provided the recommendations of this report are implemented during design and construction.

If you have any questions regarding this report, or if we may be of further service, please contact the undersigned at your convenience.

Sincerely,

**GEOCON CONSULTANTS, INC.**

**DRAFT**

Shane Rodacker, GE  
Senior Engineer

(1/e-mail) Addressee

## TABLE OF CONTENTS

1.	PURPOSE AND SCOPE .....	1
2.	SITE CONDITIONS AND PROJECT DESCRIPTION .....	1
3.	GEOLOGIC SETTING.....	2
4.	GEOLOGIC HAZARDS .....	2
4.1	Faulting and Seismicity .....	2
4.2	Surface Fault Rupture .....	3
4.3	Ground Shaking.....	3
4.4	Liquefaction.....	3
4.5	Landslides.....	4
4.6	Tsunamis and Seiches.....	4
5.	SOIL AND GROUNDWATER CONDITIONS .....	4
5.1	Terrace Deposits .....	4
5.2	Purisima Formation .....	4
5.3	Groundwater .....	5
5.4	Soil Corrosion Screening .....	5
6.	CONCLUSIONS AND RECOMMENDATIONS .....	6
6.1	General .....	6
6.2	Seismic Design Criteria .....	6
6.3	Soil and Excavation Characteristics .....	8
6.4	Materials for Fill .....	8
6.5	Grading.....	8
6.6	Temporary Excavations .....	9
6.7	Shallow Foundations .....	9
6.8	Underground Utilities .....	10
6.9	Concrete Slabs-on-Grade .....	11
6.10	Moisture Protection Considerations .....	11
6.11	Pavement Recommendations .....	12
6.12	Temporary Shoring.....	14
6.13	Retaining Wall Design.....	15
6.14	Surface Drainage .....	16
7.	FURTHER GEOTECHNICAL SERVICES .....	17
7.1	Plan and Specification Review.....	17
7.2	Testing and Observation Services .....	17

### LIMITATIONS AND UNIFORMITY OF CONDITIONS

### FIGURES

Figure 1, Vicinity Map

Figure 2, Site Plan

### APPENDIX A – FIELD INVESTIGATION

Figure A1, Key to Boring Logs

Figures A2 through A5, Logs of Exploratory Borings B1 through B4

### APPENDIX B – LABORATORY TESTING

Table B-I, Summary of Laboratory Atterberg Limits Test Results

Table B-II, Summary of Laboratory Fines Content Test Results

Table B-IV, Summary of Laboratory Direct Shear Test Results

Table B-V, Summary of Screening-Level Corrosion Parameters

Figures B1 through B6, Summary of Laboratory Particle Size Analyses

### APPENDIX C – LOGS OF SOIL BORINGS BY OTHERS

### LIST OF REFERENCES



# GEOTECHNICAL INVESTIGATION

## 1. PURPOSE AND SCOPE

This report presents the results of a geotechnical investigation for the proposed new Dream Inn Mixed Use Development in Santa Cruz, California (see Vicinity Map, Figure 1). The purpose of this investigation was to evaluate the subsurface soil and geologic conditions in the area of planned development and provide conclusions and recommendations pertaining to the geotechnical aspects of project design and construction, based on the conditions encountered during our study.

The scope of this investigation included field exploration, laboratory testing, engineering analysis, and the preparation of this report. Our field exploration was performed on March 15, 2017 and included 4 soil borings to maximum depths of approximately 30 feet or less at the site. The locations of our exploratory borings are depicted on the Site Plan, Figure 2. A detailed discussion of our field investigation and soil boring logs are presented in Appendix A.

Laboratory tests were performed on selected soil samples obtained during the investigation to evaluate pertinent geotechnical parameters. Appendix B presents the laboratory test results in tabular format and graphical format. Logs of previous soil borings by others are included in Appendix C.

The opinions expressed herein are based on analysis of the data obtained during the investigation and our experience with similar soil and geologic conditions. References reviewed to prepare this report are provided in the *List of References* section.

If project details vary significantly from those described herein, Geocon should be contacted to determine the necessity for review and possible revision of this report.

## 2. SITE CONDITIONS AND PROJECT DESCRIPTION

The project site is an approximately 2 ¼-acre parcel (Santa Cruz County APN 004-081-12) at the northwest corner of Bay Street and West Cliff Drive in Santa Cruz. The site is currently an at-grade parking lot with associated areas of landscaping that include large mature trees. Existing development in the near vicinity of the site includes the 10-story Dream Inn hotel to the east (across West Cliff Drive), 3-story multifamily residential to the south and a mobile home community to the north and west. Topographically, the site is relatively flat with ground surface elevations on the order of 50 feet MSL per topographic information provided by Ensemble Investments (Bowman and Williams, 2015). Site drainage is accomplished through surface flow to an onsite storm drain system.

The new development will include a 4-story building containing 87 multi-family residential units and a variety of street-level retail suites in the eastern portion of the site. A single level of underground parking is proposed throughout the site limits and an additional 4 above-grade decks will comprise a parking structure in western half of the site. Residential units in the western portion of the development will wrap around the parking structure. Residential units in the eastern portion of the site will sit atop the street-level retail. A public plaza and alleyways will be constructed amongst the retail suites with connectivity to the adjacent city streets and sidewalks. Ancillary site improvements such as new underground utilities, exterior flatwork and landscaping areas also anticipated.

### **3. GEOLOGIC SETTING**

Santa Cruz is located within the Coast Ranges Geomorphic Province of California, which is characterized by a series of northwest trending mountains and valleys along the north and central coast of California. Topography is controlled by the predominant geological structural trends within the Coast Range that generally consist of northwest trending synclines, anticlines and faulted blocks. The dominant structure is a result of both active northwest trending strike-slip faulting, associated with the San Andreas Fault system, and east-west compression within the province.

The San Andreas Fault (SAF) is a major right-lateral strike-slip fault that extends from the Gulf of California in Mexico to Cape Mendocino in northern California. The SAF forms a portion of the boundary between two tectonic plates on the surface of the earth. To the west of the SAF is the Pacific Plate, which moves north relative to the North American Plate, located east of the fault. Basement rock west of the SAF is generally granitic, while to the east it consists of a chaotic mixture of highly deformed marine sedimentary, submarine volcanic and metamorphic rocks of the Franciscan Complex. Both are typically Jurassic to Cretaceous in age (205 to 65 million years old). Overlying the basement rocks are Cretaceous (about 140 to 65 million years old) marine, as well as Tertiary (about 65 to 1.6 million years old) marine and non-marine sedimentary rocks with some continental volcanic rock. These Cretaceous and Tertiary rocks have typically been extensively folded and faulted largely as a result of movement along the SAF system, which has been ongoing for about the last 25 million years, and regional compression during the last about 4 million years.

Available geologic information published by the United States Geological Survey (USGS) indicates the suite is underlain by Pleistocene-age marine terrace deposits over Tertiary-age Purisima Formation.

### **4. GEOLOGIC HAZARDS**

#### **4.1 Faulting and Seismicity**

The site is not located within an Alquist-Priolo Earthquake Fault Zone as established by the State of California around known active faults. A review of the referenced geologic materials and our knowledge of the general area indicate that the site is not underlain by active faults.

The table below presents approximate distances to active faults in the site vicinity based on web-based mapping by the USGS and California Geological Survey (CGS). Site latitude is 37.6874° N; site longitude is 121.7661° W.

**TABLE 4.1  
REGIONAL FAULT SUMMARY**

Fault Name	Distance to Site (miles)	Maximum Earthquake Magnitude, $M_w$
Monterey Bay – Tularcitos	6 ¼	7.2
Zayante – Vergeles (Lower)	6 ½	7.0
Zayante – Vergeles (Upper)	8 ¾	7.0
San Gregorio	10	7.4
San Andreas (Santa Cruz Mountains)	11 ½	8.0
Sargent	12 ½	7.0

The faults tabulated above are sources of potential ground motion. However, earthquakes that might occur on other faults within northern and central California are also potential generators of significant ground motion and could subject the site to intense ground shaking.

#### **4.2 Surface Fault Rupture**

The site is not within a currently established State of California Earthquake Fault Zone for surface fault rupture hazards. No active or potentially active faults are known to pass directly beneath the site. Therefore, the potential for surface rupture due to faulting occurring beneath the site during the design life of the proposed development is considered low. CGS defines an active fault as a fault that shows evidence for activity within the last 11,000 years. A potentially active fault is generally defined as a fault that has shown evidence of displacement between 11,000 and 1.6 million years ago. Faults that have not demonstrated evidence of movement with the past 1.6 million years are generally considered inactive.

#### **4.3 Ground Shaking**

We used the beta version of the USGS web-based application *Unified Hazard Tool* to estimate peak ground acceleration (PGA) and modal (most probable) magnitude associated with a 2,475-year return period. This return period corresponds to an event with 2% chance of exceedance in a 50-year period. The USGS-estimated PGA is 0.90g and the modal magnitude is 7.9 for Seismic Site Class C/D ( $V_s30$  of 360 m/sec).

While listing PGA is useful for comparison of potential effects of fault activity in a region, other considerations are important in seismic design, including frequency and duration of motion and soil conditions underlying the site.

#### **4.4 Liquefaction**

The site is not located within a State of California Seismic Hazard Zone Hazard Zone for liquefaction. Older geologic mapping by the USGS indicates the site has a low potential for liquefaction. Liquefaction is a phenomenon in which saturated cohesionless soils are subject to a temporary loss of shear strength due to pore pressure buildup under the cyclic shear stresses associated with intense earthquakes. Primary factors that trigger liquefaction are: moderate to strong ground shaking (seismic source), relatively clean, loose

granular soils (primarily poorly graded sands and silty sands), and saturated soil conditions (shallow groundwater). Due to the increasing overburden pressure with depth, liquefaction of granular soils is generally limited to the upper 50 feet of a soil profile.

Based on the absence of a static groundwater table, the depth of the proposed underground level and the dense to very dense nature of the underlying formational materials, it is our opinion that the potential for liquefaction occurring within the site soils is low.

#### **4.5 Landslides**

There are no known landslides near the site nor is the site in the path of any known or potential landslides. We did not observe overt indications of landslide or slope instability during our investigation. We do not consider the potential for a landslide to be a significant hazard to this project.

#### **4.6 Tsunamis and Seiches**

Based on mapping by the California Emergency Management Agency, the site would not be inundated during an extreme tsunami. Ground surface elevations at the site are on the order of 50 feet MSL.

Seiches are large waves generated in enclosed bodies of water in response to ground shaking. No major water-retaining structures are located immediately up gradient from the project site. Flooding from a seismically-induced seiche is considered unlikely.

### **5. SOIL AND GROUNDWATER CONDITIONS**

#### **5.1 Terrace Deposits**

Our soil borings encountered marine terrace deposits that were observed as loose to medium dense sands with variable amounts of fines (silts and clays). In general, the silt and clay content of the sands decreased with depth. Our borings encountered terrace deposits to depths of approximately 13 to 14 feet where soil conditions transitioned to weathered formational materials. The contact between terrace deposits and underlying formational materials is likely gradational and may vary across the site.

#### **5.2 Purisima Formation**

Each of soil borings encountered Tertiary-age Purisima Formation beneath the overlying terrace deposits. The formation is described in USGS references as tuffaceous and diatomaceous siltstone with thick interbeds of semi-friable, fine-grained andesitic sandstone. The Purisima Formation materials in our soil borings were observed as weak, moderately to highly weathered sandstone that excavated as fine sand. Based on sampler resistance, the sands weathered from the sandstone are dense to very dense in situ and will provide good foundation support characteristics.

### **5.3 Groundwater**

Groundwater was encountered in our soil borings at depths of approximately 12 to 16 feet. Based on our observations during drilling, we anticipate this groundwater is perched on the dense formation materials rather than a static groundwater table. Groundwater levels will vary seasonally and fluctuate with variations in rainfall, temperature and other factors and may be higher or lower than observed during our study.

### **5.4 Soil Corrosion Screening**

Soil samples obtained during our field exploration were subjected to laboratory testing for minimum resistivity, pH, and chloride and water-soluble sulfate. The laboratory test results and published screening levels are presented in Appendix B. Soil corrosivity should be considered in the design of buried metal pipes, underground structures, etc.

Water-soluble sulfate test results on selected samples of site soils indicate an S0 exposure classification for sulfate attack on normal portland cement concrete (PCC) as defined in Chapter 318, Table 19.3.1.1 of the *ACI Building Code Requirements for Structural Concrete*. ACI does not set forth requirements for S0 sulfate exposure classification. In addition, neither of the two soil samples tested would be classified as corrosive to buried metal improvements based on Caltrans corrosion criteria.

Geocon does not practice in the field of corrosion engineering and mitigation. If corrosion sensitive improvements are planned, it is recommended that a corrosion engineer be retained to evaluate corrosion test results and incorporate the necessary precautions to avoid premature corrosion of buried metal pipes and concrete structures in direct contact with the soils.

## 6. CONCLUSIONS AND RECOMMENDATIONS

### 6.1 General

- 6.1.1 It is our opinion that neither soil nor geologic conditions were encountered during our investigation that would preclude the project as presently proposed.
- 6.1.2 Key geotechnical considerations for the project are loose, relatively clean sands that will be encountered in planned excavations and the presence of a perched groundwater condition that may require localized dewatering measures if encountered during construction.
- 6.1.3 All references to relative compaction and optimum moisture content in this report are based on ASTM D 1557 (latest edition).
- 6.1.4 The proposed project redevelops a site with past episodes of grading and construction. As such, unknown underground improvements and areas of undocumented fill materials (not discussed herein) may be present. If encountered, supplemental recommendations will be provided during site development.
- 6.1.5 Project civil and structural plans should be provided for our review. Supplemental recommendations and/or modifications to the recommendations presented herein may be required.
- 6.1.6 For foundation systems constructed as described herein, we estimate that post-construction settlement due foundation loads will be less than approximately 1 inch, and corresponding differential settlement will be less than  $\frac{3}{4}$  inch across a horizontal distance of 50 feet. Final design foundation loadings should be reviewed by Geocon.
- 6.1.7 Excavation for subterranean level will likely require shoring along portions of the site perimeter. The presence of improvements and possibly traffic surcharges will require consideration in the design of temporary and permanent retaining structures. General recommendations for the design of temporary shoring and permanent retaining walls are presented herein. We should review shoring system and retaining wall designs for the appropriate incorporation of geotechnical parameters and application of surcharge loading conditions; supplemental recommendations may be required on a case-by-case basis.
- 6.1.8 Any changes in the design, location or elevation of the proposed improvements, as outlined in this report, should be reviewed by this office. Geocon should be contacted to determine the necessity for review and possible revision of this report.

### 6.2 Seismic Design Criteria

- 6.2.1 We understand that seismic structural design will be performed in accordance with the provisions of the 2016 CBC which is based on the American Society of Civil Engineers (ASCE) publication *Minimum Design Loads for Buildings and Other Structures* (ASCE 7-10). We used the USGS web-based application *US Seismic Design Maps* to evaluate site-specific seismic design

parameters in accordance with the 2016 CBC and ASCE 7-10. Results are summarized in Table 6.2.1. The values presented are for the risk-targeted maximum considered earthquake (MCE<sub>R</sub>).

**TABLE 6.2.1  
2016 CBC SEISMIC DESIGN PARAMETERS**

Parameter	Value	2016 CBC / ASCE 7-10 Reference
Site Class	D	Section 1613.3.2/ Table 20.3-1
MCE <sub>R</sub> Ground Motion Spectral Response Acceleration – Class B (short), S <sub>S</sub>	1.5g	Figure 1613.3.1(1) / Figure 22-1
MCE <sub>R</sub> Ground Motion Spectral Response Acceleration – Class B (1 sec), S <sub>1</sub>	0.6g	Figure 1613.3.1(2) / Figure 22-2
Site Coefficient, F <sub>A</sub>	1.0	Table 1613.3.3(1) / Table 11.4-1
Site Coefficient, F <sub>V</sub>	1.5	Table 1613.3.3(2) / Table 11.4-2
Site Class Modified MCE <sub>R</sub> Spectral Response Acceleration (short), S <sub>MS</sub>	1.5g	Eq. 16-37 / Eq. 11.4-1
Site Class Modified MCE <sub>R</sub> Spectral Response Acceleration (1 sec), S <sub>M1</sub>	0.9g	Eq. 16-38 / Eq. 11.4-2
5% Damped Design Spectral Response Acceleration (short), S <sub>DS</sub>	1.0g	Eq. 16-39 / Eq. 11.4-3
5% Damped Design Spectral Response Acceleration (1 sec), S <sub>D1</sub>	0.6g	Eq. 16-40 / Eq. 11.4-4

6.2.2 Table 6.2.2 presents additional seismic design parameters for projects with Seismic Design Categories of D through F in accordance with ASCE 7-10 for the mapped maximum considered geometric mean (MCE<sub>G</sub>).

**TABLE 6.2.2  
2016 CBC SITE ACCELERATION DESIGN PARAMETERS**

Parameter	Value	ASCE 7-10 Reference
Mapped MCE <sub>G</sub> Peak Ground Acceleration, PGA	0.51g	Figure 22-7
Site Coefficient, F <sub>PGA</sub>	1.0	Table 11.8-1
Site Class Modified MCE <sub>G</sub> Peak Ground Acceleration, PGA <sub>M</sub>	0.51g	Section 11.8.3 (Eq. 11.8-1)

6.2.3 Conformance to the criteria presented in Tables 6.2.1 and 6.2.2 for seismic design does not constitute any kind of guarantee or assurance that significant structural damage or ground failure will not occur if a maximum level earthquake occurs. The primary goal of seismic design is to protect life and not to avoid structural damage, since such design may be economically prohibitive.

### **6.3 Soil and Excavation Characteristics**

- 6.3.1 Based on the soils conditions encountered in our exploratory borings, the majority of onsite soils can be excavated with moderate to heavy effort using conventional excavation equipment. We do not anticipate excavations in the native soils and formational materials will generate oversize material (greater than 6 inches in nominal dimension). In general, the strength and weathering of the formational materials are anticipated to increase and decrease, respectively, with depth. The formational materials were readily drillable with our truck-mounted hollow-stem auger drill rig. Excavations below the depth explored in our investigation may encounter different conditions.
- 6.3.2 It is the responsibility of the contractor to ensure that all excavations and trenches are properly shored and maintained in accordance with applicable Occupational Safety and Health Administration (OSHA) rules and regulations to maintain safety and maintain the stability of adjacent existing improvements.
- 6.3.3 We did not observe soils that would be considered expansive as defined by 2016 CBC during our field exploration. The recommendations presented in this report assume that foundations for the project will derive support in Purisima Formation.

### **6.4 Materials for Fill**

- 6.4.1 Excavated soils generated from cut operations at the site are suitable for use as engineered fill in structural areas provided they do not contain deleterious matter, organic material, or cementations larger than 6 inches in maximum dimension.
- 6.4.2 Import or low-expansive material should be well-graded, primarily granular with a “very low” expansion potential (Expansion Index less than 20), a Plasticity Index less than 15, be free of organic material and construction debris, and not contain rock larger than 6 inches in greatest dimension.
- 6.4.3 Environmental characteristics and corrosion potential of import soil materials may also be considered. Proposed import materials should be sampled, tested, and approved by Geocon prior to its transportation to the site.

### **6.5 Grading**

- 6.5.1 All earthwork should be observed and all fills tested for recommended compaction and moisture content by representatives of Geocon.
- 6.5.2 A preconstruction conference should be held at the site prior to the beginning of grading operations with the owner, contractor, civil engineer and geotechnical engineer in attendance. Special soil handling requirements can be discussed at that time.
- 6.5.3 After demolition of the existing improvements and excavation for the subterranean level, subgrade for the subterranean level should be moisture conditioned to near optimum moisture content and compacted to at least 90% relative compaction to provide a relatively uniform support characteristic for the slab-on-grade.



- 6.5.4 Although not expected, any active or inactive utilities within the construction area after excavation for the underground level should be protected, relocated, or abandoned. Any pipelines to be abandoned that are greater than 2 inches and less than 18 inches in diameter should be removed or filled with sand-cement slurry. Utilities larger than 18 inches in diameter should be removed. Excavations or depressions resulting from site clearing operations, or other existing excavations or depressions, should be restored with engineered fill in accordance with the recommendations of this report.
- 6.5.5 All structural fill (including scarified ground surfaces and backfill) should be placed in layers no thicker than will allow for adequate bonding and compaction (typically 8 inches). Fill soils should be placed, moisture conditioned to near optimum moisture content and compacted to at least 92% relative compaction.
- 6.5.6 If grading commences in winter or spring, or in periods of precipitation, excavated and in-place soils may be, or become, wet. Earthwork contractors should be aware of moisture sensitivity of fine-grained soils and potential compaction/workability difficulties. It has been our experience the subgrade soils protected by pavement are typically moist to wet and may require drying prior to re-use as engineered fill. The most effective site preparation alternatives will depend on site conditions prior to and during grading operations; we should evaluate site conditions at those times and provide supplemental recommendations, if necessary.

## **6.6 Temporary Excavations**

- 6.6.1 We anticipate that much of the native terrace deposits can be considered a Type B soil in accordance with OSHA guidelines. If free water, clean and/or loose sandy soils or undocumented fills are encountered the materials should be downgraded to Type C. The contractor should have a “competent person” as defined by OSHA evaluate all excavations. All onsite excavations must be conducted in such a manner that potential surcharges from existing structures, construction equipment, and vehicle loads are resisted. The surcharge area may be defined by a 1:1 projection down and away from the bottom of an existing foundation or vehicle load. Penetrations below this 1:1 projection will require special excavation measures such as sloping and possibly shoring.
- 6.6.2 It is the contractor’s responsibility to provide sufficient and safe excavation support as well as protecting nearby utilities, structures, and other improvements which may be damaged by earth movements.

## **6.7 Shallow Foundations**

- 6.7.1 The proposed building may use conventional shallow foundations consisting of continuous strip and isolated spread footings bearing entirely in competent terrace deposits and/or formational materials. Based on the planned depth of the subterranean level, we anticipate that most footing excavations will encounter competent terrace deposits or formational materials. Where footing excavations do not expose competent soil conditions or formational materials, measures such as localized over-excavation or recompaction may be required in footing excavations. If required, over-excavations may be backfilled with lean concrete slurry or additional structural concrete.

- 6.7.2 It is recommended that strip and spread footings have a minimum embedment depth of 18 inches below lowest adjacent pad grade. The footings should be at least 24 inches wide.
- 6.7.3 Footings proportioned as recommended and founded at least 13 feet below existing grades may be designed for an allowable soil bearing pressure of 8,000 pounds per square foot (psf). The allowable bearing pressure is for dead + live loads may be increased by up to one-third for transient loads due to wind or seismic forces.
- 6.7.4 The allowable passive pressure used to resist lateral movement may be assumed to be equal to a fluid weighing 350 pounds per cubic foot (pcf) for footings poured neat against competent undisturbed terrace deposits or formational materials. The allowable passive pressure assumes a horizontal surface extending at least 5 feet or 3 times the surface generating the passive pressure, whichever is greater. The allowable coefficient of friction to resist sliding is 0.30 for concrete against soil. Combined passive resistance and friction may be utilized for design provided that the frictional resistance is reduced by 50%. Where not protected by flatwork or pavement, the upper 1 foot of soil should be neglected when calculating passive resistance to lateral loads.
- 6.7.5 Minimum reinforcement for continuous footings should consist of four No. 4 steel reinforcing bars; two placed near the top of the footing and two near the bottom.
- 6.7.6 Underground utilities running parallel to footings should not be constructed in the zone of influence of footings. The zone of influence may be taken to be the area beneath the footing and within a 1:1 plane extending out and down from the bottom edge of the footing.
- 6.7.7 The foundation subgrade should be sprinkled as necessary to maintain a moist condition without significant shrinkage cracks as would be expected in any concrete placement. Prior to placing rebar reinforcement, foundation excavations should be evaluated by our representatives for appropriate support characteristics and moisture content. Moisture conditioning may be required for the materials exposed in footing excavations, particularly if foundation excavations are left open for an extended period.

## **6.8 Underground Utilities**

- 6.8.1 Underground utility trenches should be backfilled with properly compacted material. The material excavated from the trenches should be adequate for use as backfill provided it does not contain deleterious matter, vegetation or rock larger than six inches in maximum dimension. Trench backfill should be placed in loose lifts not exceeding eight inches and should be compacted to at least 92% relative compaction at near optimum moisture content.
- 6.8.2 Bedding and pipe zone backfill typically extends from the bottom of the trench excavations to a minimum of 6 inches above the crown of the pipe. Pipe bedding and backfill material should conform to the requirements of the governing utility agency. Proposed bedding and pipe zone materials should be reviewed by Geocon prior to construction; materials such as ¾-inch drain rock may require wrapping with filter fabric to mitigate the potential for piping.

## **6.9 Concrete Slabs-on-Grade**

- 6.9.1 Concrete slabs-on-grade subject to vehicle loading should be designed in accordance with the recommendations in Section 6.11 of this report.
- 6.9.2 Concrete slabs-on-grade for structures, not subject to vehicle loading, should be a minimum of 5 inches thick and minimum slab reinforcement should consist of No. 3 steel reinforcing bars placed 24 inches on center in both horizontal directions. Steel reinforcing should be positioned vertically near the slab midpoint.
- 6.9.3 Interior slabs or slabs in areas where moisture would be objectionable should be underlain by 3 inches of ½-inch or ¾-inch crushed rock with no more than 5% passing the No. 200 sieve to serve as a capillary break.
- 6.9.4 Exterior slabs, not subject to traffic loads, should be at least 4 inches thick and reinforced with No. 3 steel reinforcing bars placed 24 inches on center in both horizontal directions, positioned near the slab midpoint. Slab subgrade should be moisture conditioned to near optimum and properly compacted to at least 92% relative compaction.
- 6.9.5 Crack control joints should be spaced at intervals not greater than 8 feet for 4-inch-thick slabs (10 feet for 5-inch slabs) and should be constructed using saw-cuts or other methods as soon as practical following concrete placement. Crack control joints should extend a minimum depth of one-fourth the slab thickness and should be constructed using saw-cuts or other methods as soon as practical after concrete placement. Construction joints should be designed by the project structural engineer.
- 6.9.6 The recommendations of this report are intended to reduce the potential for cracking of slabs due to soil movement. However, even with the incorporation of the recommendations presented herein, foundations, stucco walls, and slabs-on-grade may exhibit some cracking due to soil movement. This is common for project areas that contain expansive soils since designing to eliminate potential soil movement is cost prohibitive. The occurrence of concrete shrinkage cracks is independent of the supporting soil characteristics. Their occurrence may be reduced and/or controlled by limiting the slump of the concrete, proper concrete placement and curing, and by the placement of crack control joints at periodic intervals, in particular, where re-entrant slab corners occur.

## **6.10 Moisture Protection Considerations**

- 6.10.1 A vapor barrier is not required beneath slab-on-grade for geotechnical purposes. Further, the migration of moisture through concrete slabs or moisture otherwise released from slabs is not a geotechnical issue. However, for convenience of the design-build team, we are providing the following recommendations. The suggested procedures may reduce the potential for moisture-related floor covering failures on concrete slabs-on-grade, but moisture problems may still occur even if the procedures are followed. If more detailed recommendations are desired, we recommend consulting a specialist in this field. If a vapor barrier is used beneath mat slab foundations, the frictional contribution to sliding resistance should be neglected.

- 6.10.2 A vapor barrier meeting ASTM E 1745-09 Class C requirements may be placed directly below the slab, without a sand cushion. To reduce the potential for punctures, a higher quality vapor barrier (15 mil, Class A or B) should be used. The vapor barrier, if used, should extend to the edges of the slab, and should be sealed at all seams and penetrations.
- 6.10.3 The concrete water/cement ratio should be as low as possible. The water/cement ratio should not exceed 0.45 for concrete placed directly on the vapor barrier. Midrange plasticizers could be used to facilitate concrete placement and workability.
- 6.10.4 Proper finishing, curing, and moisture vapor emission testing should be performed in accordance with the latest guidelines provided by the American Concrete Institute, Portland Cement Association, and ASTM.

**6.11 Pavement Recommendations**

- 6.11.1 The upper 12 inches of pavement subgrade should be scarified, moisture conditioned to near optimum and compacted to at least 95% relative compaction. Prior to placing aggregate base, the finished subgrade should be proof-rolled with a laden water truck (or similar equipment with high contact pressure) to verify stability.
- 6.11.2 We recommend the following asphalt concrete (AC) pavement sections for design to establish subgrade elevations in pavement areas. The project civil engineer should determine the appropriate Traffic Index (TI) based on anticipated traffic conditions. The flexible pavement sections below are based on estimated design TIs. We can provide additional sections based on other TIs if necessary.

**TABLE 6.11  
FLEXIBLE PAVEMENT SECTION RECOMMENDATIONS**

Location	Estimated Traffic Index (TI)	AC (inches)	AB (inches)
Parking Stalls	4.5	3	6
Driveways	6.0	3 ½	9 ½
Heavy Duty	7.0	4	12
Heavy Duty	8.0	5	13 ½

Note: The recommended flexible pavement sections are based on the following assumptions:

1. Subgrade soil has an R-Value of 20.
2. AB: Class 2 AB with a minimum R-Value of 78 and meeting the requirements of Section 26 of the latest Caltrans Standard Specifications.
3. AB is compacted to 95% or higher relative compaction at or near optimum moisture content. Prior to placing AB, the subgrade should be proof-rolled with a loaded water truck to verify stability.
4. AC: Asphalt concrete conforming to local agency standards or Section 39 of the latest Caltrans Standard Specifications.

- 6.11.3 The AC sections in Table 6.11 are final, minimum thicknesses. If staged-pavements are used, the construction bottom AC lift should be at least 2 inches thick. Following construction, the finish top AC lift should be at least 1½ inches thick.
- 6.11.4 Unless specifically designed and evaluated by the project structural engineer, where concrete paving will be utilized for support of vehicles, we recommend the concrete be a minimum of 6 inches thick and reinforced with No. 3 steel reinforcing bars placed 24 inches on center in both horizontal directions. In addition, doweling, reinforcing steel or other load-transfer mechanism should be provided at joints if desired to reduce the potential for vertical offset. Where the floor slab for the underground parking level will be subjected to only passenger car traffic, the concrete thickness may be reduced to 5 inches.
- 6.11.5 We recommend that at least 6 inches of Class 2 aggregate base be used below rigid concrete pavements. The aggregate base should be compacted to at least 95% relative compaction near optimum moisture content. This aggregate base layer may be omitted where the floor slab for the underground parking since only passenger car traffic is expected.
- 6.11.6 In general, we recommend that concrete pavements be designed, constructed and maintained in accordance with industry standards such as those provided by the American Concrete Pavement Association.
- 6.11.7 Crack control joints should be spaced at intervals not greater than 12 feet for 6-inch-thick slabs (10 feet for 5-inch slabs) and should be constructed using saw-cuts or other methods as soon as practical following concrete placement. Crack control joints should extend a minimum depth of one-fourth the slab thickness and should be constructed using saw-cuts or other methods as soon as practical after concrete placement. Construction joints should be designed by the project structural engineer.
- 6.11.8 The performance of pavements is highly dependent upon providing positive surface drainage away from the edge of pavements. Ponding of water on or adjacent to the pavement will likely result in saturation of the subgrade materials and subsequent cracking, subsidence and pavement distress. If planters are planned adjacent to paving, it is recommended that the perimeter curb be extended at least 6 inches below the bottom of the aggregate base to minimize the introduction of water beneath the paving. Alternatives such as plastic moisture cut-offs or modified drop-inlets may also be considered in lieu of deepened curbs.
- 6.11.9 Asphalt pavement section recommendations for driveways and parking areas are based on the design procedures of Caltrans' Highway Design Manual (HDM). It should be noted that most rational pavement design procedures are based on projected street or highway traffic conditions and, hence, may not be representative of vehicular loading that occurs in parking lots and driveways. Pavement proximity to landscape irrigation, reduced traffic speed and short turning radii increase the potential for pavement distress to occur in parking lots even though the volume of traffic is significantly less than that of an adjacent street. The HDM indicates that the resulting pavement sections for parking lots are minimized to keep initial costs down but are reasonable because additional AC surfacing can be added later, if needed, and generally without incurring traffic hazards or traffic handling problems. It is generally not economically feasible to design

and construct the entire parking lot and driveways for the unique loading conditions previously described. Periodic maintenance of the pavement in these areas, therefore, should be anticipated.

## **6.12 Temporary Shoring**

- 6.12.1 The design of temporary shoring is governed by soil and groundwater conditions, as well as the depth and width of the excavated area. Continuous support of the excavation face may be provided by a system of soldier piles and wood lagging. Excavations exceeding approximately 12 to 15 feet, or those with surcharge loading, may require tieback anchors or other supplemental anchorage or bracing to provide additional wall restraint. We have assumed the project shoring system will not require tiebacks; recommendations can be provided upon request.
- 6.12.2 Temporary cantilever shoring should be designed for an active soil pressure equivalent to the pressure exerted by a fluid density of 25 pcf. Any additional lateral earth pressure due to the surcharge effects of adjacent structures and/or traffic loads should be considered, where appropriate, during design of the shoring system.
- 6.12.3 Passive soil pressure resistance for soldier piles embedded in competent terrace deposits or formational materials can be based upon an equivalent passive soil fluid weight of 400 pcf. The passive resistance can be assumed to act over a width of two pile diameters. The project structural engineer or shoring designer should determine the actual embedment depth. Where not protected by pavement or slabs, the upper one foot of soil should be ignored when calculating passive soil resistance.
- 6.12.4 The frictional resistance between the soldier piles and retained soil may be used to resist the vertical component of the anchor load (if any). The coefficient of friction may be taken as 0.25 based on uniform contact between the steel beam and lean-mix concrete and surrounding soil. This value may be increased to 0.30 where structural concrete is used. The portion of soldier piles below the plane of excavation may also be employed to resist the downward loads. The downward capacity may be determined using an allowable end bearing of 5,000 pounds per square foot.
- 6.12.5 Drilled cast-in-place soldier piles should be placed no closer than 3 diameters on center. The minimum diameter of the piles is 18 inches. Structural concrete should be used for the soldier piles below the excavation. As an alternative, lean-mix concrete may be used where the pile reinforcing consists of a wide-flange section. The slurry must be of sufficient strength to impart the lateral bearing pressure developed by the wide-flange section to the soil.
- 6.12.6 Casing may be required if caving is experienced in granular soil zones and the contractor should have casing available prior to commencement of drilling activities. When casing is used, extreme care should be employed so that the pile integrity is not compromised as the casing is withdrawn. At no time should the distance between the surface of the concrete and the bottom of the casing be less than five feet. A representative of Geocon should observe the drilling of soldier piles and construction of the shoring system on a continuous basis.
- 6.12.7 Although not expected, a special concrete mix should be used for concrete to be placed below water. The design should provide for concrete with a 28-day compressive strength psi of 1,000

pounds per square inch (psi) greater than the initial job specification (minimum 4,000 psi). An admixture that reduces segregation of paste/aggregates and dilution of paste should be considered. Concrete below water should be placed via tremie method.

- 6.12.8 It is essential that the soldier pile system allow very limited amounts of lateral displacement. Earth pressures acting on a lagging wall can result in the movement of the shoring toward the excavation and result in ground subsidence outside of the excavation. For these reasons, we recommend that horizontal movements of the shoring wall be accurately monitored and recorded during excavation and anchor construction. Survey points should be established at both the top and at least one intermediate point between the top of the pile and the base of the excavation on each soldier pile. These points should be monitored on a regular basis during excavation work. Shoring systems, where adjacent offsite structures or improvements do not surcharge the shoring excavation, are typically designed to limit horizontal soldier pile movement to less than 1 inch. Where structures and/or sensitive improvements surcharge the excavations, horizontal soldier pile movement is typically limited to less than ½ inch (or no deflection if movement will damage existing structures). The allowable deflection is dependent on many factors, such as the presence of structures and utilities near the top of the excavation, and will be assessed and designed by the project shoring engineer.
- 6.12.9 Lagging should keep pace with excavation. We recommend that the excavation not be advanced deeper than 3 feet below the bottom of lagging at any time; the unlagged gaps should only be allowed to stand for short periods of time in order to decrease the probability of soil sloughing and caving. Backfilling should be conducted when necessary between the back of lagging and excavation sidewalls to reduce sloughing in this zone.
- 6.12.10 The condition of existing buildings, streets, sidewalks and other structures around the perimeter of the planned excavation should be well-documented prior to the start of shoring and excavation work. Special attention should be given to documenting existing cracks or other indications of differential settlement within these adjacent structures, pavements and other improvements. Consideration should be given to videotaping adjacent underground utilities prior to construction to verify integrity of pipes. Survey monitoring points should be established around the excavation and at existing buildings. These points should be monitored on a regular basis during construction.
- 6.12.11 Geocon should review all shoring plans prior to finalizing to confirm the incorporation of the recommendations provided herein or to provide supplemental geotechnical recommendations, as necessary.

### **6.13 Retaining Wall Design**

- 6.13.1 Lateral earth pressures may be used in the design of retaining walls and buried structures. Lateral earth pressures against these facilities may be assumed to be equal to the pressure exerted by an equivalent fluid. The unit weight of the equivalent fluid depends on the design conditions. Walls restrained from movement such as basement walls should be designed using the at-rest case. We recommend an equivalent fluid density of 75 pcf be assumed for an at-rest case. Where the basement walls will be undrained, the equivalent fluid density should be increased to 100 pcf. The above soil pressures assume level backfill within an area bounded by the wall and a 1:1 plane

extending upward from the base of the wall and no surcharges within that same area. Unless project-specific loading information is provided by the structural engineer, where typical vehicle loads are expected within 10 feet of the subterranean walls, the vehicle loading surcharge may be assumed to result in a uniform lateral pressure of 100 psf for the upper 10 feet of the retaining wall.

6.13.2 From a geotechnical standpoint, seismic lateral earth pressures may be neglected for restrained basement retaining walls designed to withstand the at-rest earth pressures in the preceding section.

6.13.3 We recommend that all retaining wall designs be reviewed by Geocon to confirm the incorporation of the recommendations provided herein. In particular, potential surcharges from adjacent structures and other improvements should be reviewed by Geocon.

## **6.14 Surface Drainage**

6.14.1 Proper surface drainage is critical to the future performance of the project. Uncontrolled infiltration of irrigation excess and storm runoff into the soils can adversely affect the performance of the planned improvements. Saturation of a soil can cause it to lose internal shear strength and increase its compressibility, resulting in a change to important engineering properties. Proper drainage should be maintained at all times.

6.14.2 All site drainage should be collected and transferred to the street in non-erosive drainage devices. Drainage should not be allowed to pond anywhere on the site, and especially not against any foundations or retaining walls. Drainage should not be allowed to flow uncontrolled over any descending slope. The proposed structures should be provided with roof gutters. Discharge from downspouts, roof drains and scuppers not permitted onto unprotected soils within five feet of the building perimeter. Planters which are located adjacent to foundations should be sealed or properly drained to prevent moisture intrusion into the materials providing foundation support. Landscape irrigation within five feet of the building perimeter footings should be kept to a minimum to just support vegetative life.

6.14.3 Positive site drainage should be provided away from structures, pavement, and the tops of slopes to swales or other controlled drainage structures. The building pad and pavement areas should be fine graded such that water is not allowed to pond. Final soil grade should slope a minimum of 2% away from structures.

6.14.4 We recommend implemented measures to reduce infiltrating surface water near buildings and slabs-on-grade. Such measures may include:

- Selecting drought-tolerant plants that require little or no irrigation, especially within three feet of buildings, slabs-on-grade, or pavements.
- Using drip irrigation or low-output sprinklers.
- Using automatic timers for irrigation systems.
- Appropriately spaced area drains.
- Hard-piping roof downspouts to appropriate collection facilities.



## **7. FURTHER GEOTECHNICAL SERVICES**

### **7.1 Plan and Specification Review**

- 7.1.1 We should review project plans and specifications prior to final design submittal to assess whether our recommendations have been properly implemented and evaluate if additional analysis and/or recommendations are required.

### **7.2 Testing and Observation Services**

- 7.2.1 The recommendations provided in this report are based on the assumption that we will continue as Geotechnical Engineer of Record throughout the construction phase and provide compaction testing and observation services and foundation observations throughout the project. It is important to maintain continuity of geotechnical interpretation and confirm that field conditions encountered are similar to those anticipated during design. If we are not retained for these services, we cannot assume any responsibility for others interpretation of our recommendations, and therefore the future performance of the project.

## LIMITATIONS AND UNIFORMITY OF CONDITIONS

The recommendations of this report pertain only to the site investigated and are based upon the assumption that the soil conditions do not deviate from those disclosed in the investigation. If any variations or undesirable conditions are encountered during construction, or if the proposed construction will differ from that anticipated herein, Geocon Consultants, Inc. should be notified so that supplemental recommendations can be given. The evaluation or identification of the potential presence of hazardous or corrosive materials was not part of the geotechnical scope of services provided by Geocon Consultants, Inc.

This report is issued with the understanding that it is the responsibility of the owner, or of his representative, to ensure that the information and recommendations contained herein are brought to the attention of the architect and engineer for the project and incorporated into the plans, and the necessary steps are taken to see that the contractor and subcontractors carry out such recommendations in the field.

The findings of this report are valid as of the present date. However, changes in the conditions of a property can occur with the passage of time, whether they are due to natural processes or the works of man on this or adjacent properties. In addition, changes in applicable or appropriate standards may occur, whether they result from legislation or the broadening of knowledge. Accordingly, the findings of this report may be invalidated wholly or partially by changes outside our control. Therefore, this report is subject to review and should not be relied upon after a period of three years.

Our professional services were performed, our findings obtained, and our recommendations prepared in accordance with generally accepted geotechnical engineering principles and practices used in the site area at this time. No warranty is provided, express or implied.

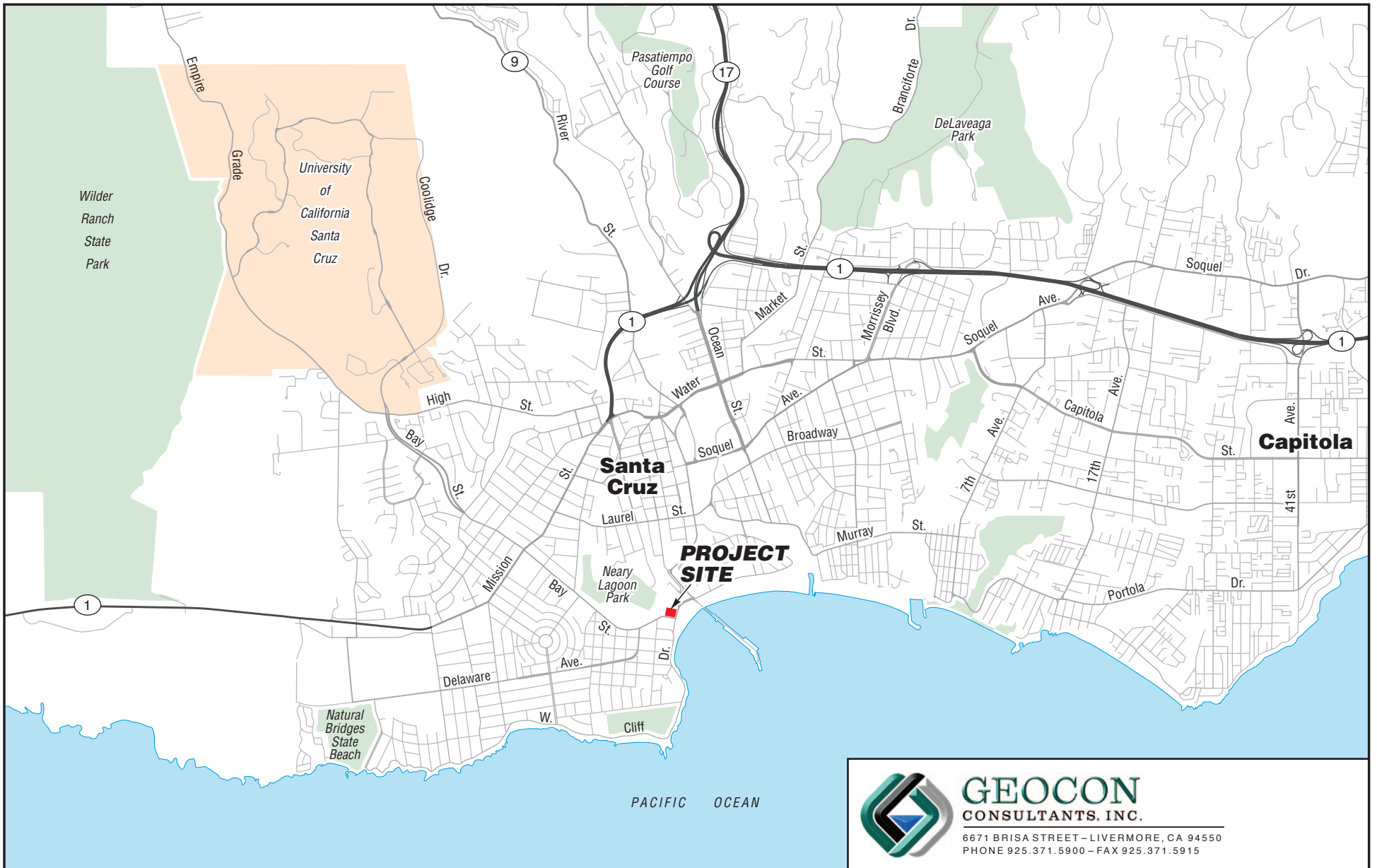

**GEOCON**  
CONSULTANTS, INC.

6671 BRISA STREET - LIVERMORE, CA 94550  
PHONE 925.371.5900 - FAX 925.371.5915

Dream Inn Mixed Use Development

Northwest Corner of W. Cliff Drive and Bay Street  
Santa Cruz, California

**VICINITY MAP**

E8978-04-01

March 2017

Figure 1

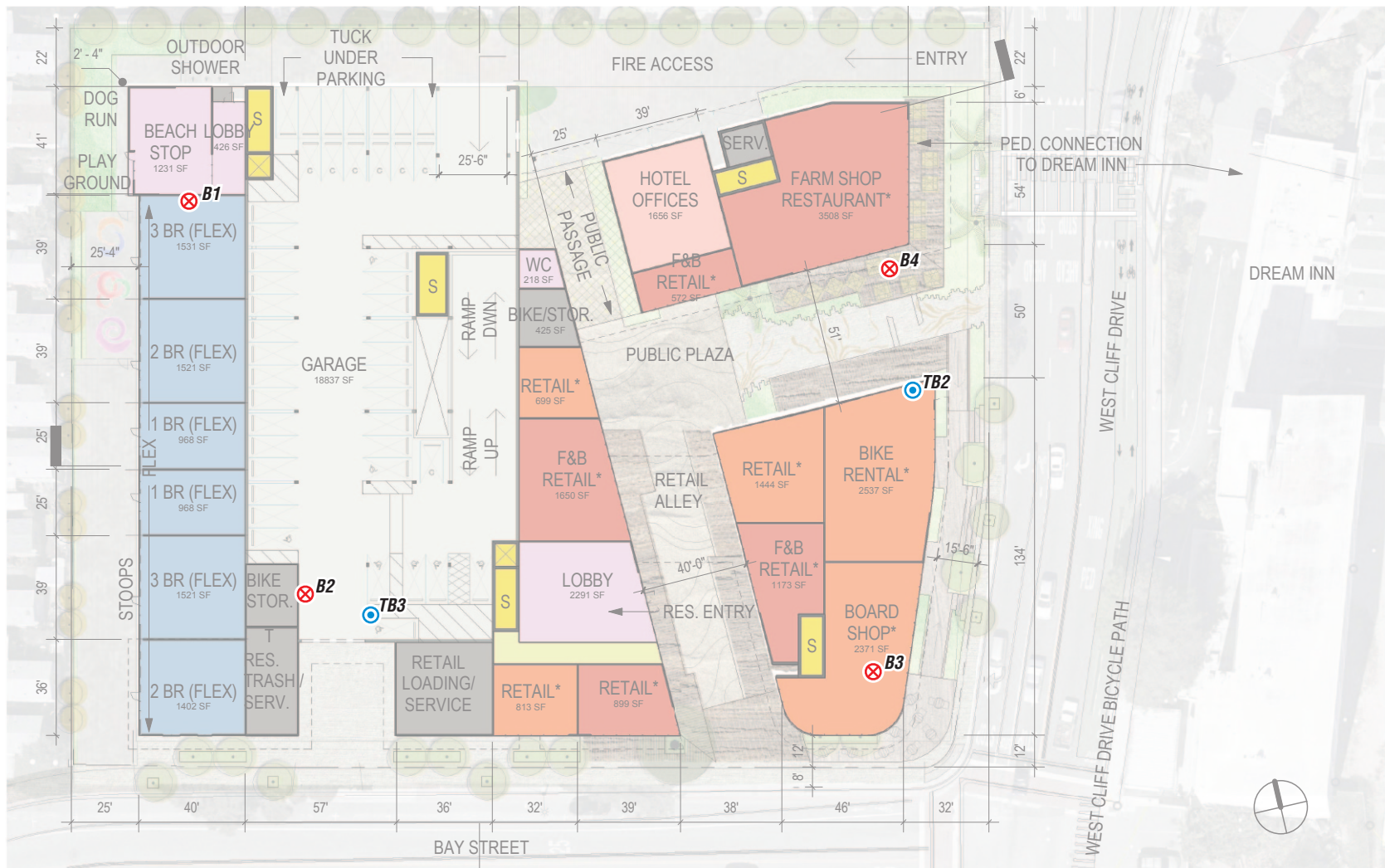

**LEGEND:**

- B4** ⊗ Approximate Geocon Boring Location, 2017
- TB2** ⊙ Approximate Treadwell & Rollo Boring Location, 2004



**GEOCON**  
CONSULTANTS, INC.

6671 BRISA STREET - LIVERMORE, CA 94550  
PHONE 925.371.5900 - FAX 925.371.5915

Dream Inn Mixed Use Development

Northwest Corner of W. Cliff Drive and Bay Street  
Santa Cruz, California

**SITE PLAN**

E8978-04-01

March 2017

Figure 2

APPENDIX

A

## **APPENDIX A FIELD EXPLORATION**

Fieldwork for our investigation included a site visit, subsurface exploration, and soil sampling. The locations of our exploratory borings are shown on the Site Plan, Figure 2. Soil boring logs are presented as figures following the text in this appendix. The borings were located in the field using a measuring tape and existing reference points. Therefore, the exploration locations shown on Figure 2 are approximate.

Our subsurface exploration was performed on March 15, 2017 and included the drilling and sampling of existing soils with a Mobile B-53 drill rig equipped with 8-inch hollow-stem augers. Sampling in the borings was accomplished using a 140-pound wireline hammer with a 30-inch drop. Samples were obtained with a 3-inch outside-diameter (OD), split spoon (California Modified) sampler, and a 2-inch OD, Standard Penetration Test (SPT) sampler. The number of blows required to drive the sampler the last 12 inches (or fraction thereof) of the 18-inch sampling interval were recorded on the boring logs. The blow counts shown on the boring logs should not be interpreted as standard SPT “N” values; corrections have not been applied. Samples were collected at appropriate intervals, classified by our field geologist, retained in moisture-tight containers and transported to the laboratory for testing and further classification. The applicable type of each sampling interval is noted on the exploratory boring logs. Upon completion, our borings were backfilled with compacted soil cuttings and neat cement and capped with quick-set concrete.

Subsurface conditions encountered in the exploratory boring were visually examined, classified and logged in general accordance with the American Society for Testing and Materials (ASTM) Practice for Description and Identification of Soils (Visual-Manual Procedure D2488). This system uses the Unified Soil Classification System (USCS) for soil designations. The log depicts soil and geologic conditions encountered and depths at which samples were obtained. The log also includes our interpretation of the conditions between sampling intervals. Therefore, the logs contain both observed and interpreted data. We determined the lines designating the interface between soil materials on the logs using visual observations, drill rig penetration rates, excavation characteristics and other factors. The transition between materials may be abrupt or gradual. Where applicable, the field log was revised based on subsequent laboratory testing.

**UNIFIED SOIL CLASSIFICATION**

MAJOR DIVISIONS		TYPICAL NAMES	
COARSE-GRAINED SOILS MORE THAN HALF IS COARSER THAN NO. 200 SIEVE	GRAVELS MORE THAN HALF COARSE FRACTION IS LARGER THAN NO. 4 SIEVE SIZE	CLEAN GRAVELS WITH LITTLE OR NO FINES	GW WELL GRADED GRAVELS WITH OR WITHOUT SAND, LITTLE OR NO FINES
		GRAVELS WITH OVER 12% FINES	GP POORLY GRADED GRAVELS WITH OR WITHOUT SAND, LITTLE OR NO FINES
	SANDS MORE THAN HALF COARSE FRACTION IS SMALLER THAN NO. 4 SIEVE SIZE	CLEAN SANDS WITH LITTLE OR NO FINES	GM SILTY GRAVELS, SILTY GRAVELS WITH SAND
			GC CLAYEY GRAVELS, CLAYEY GRAVELS WITH SAND
		SANDS WITH OVER 12% FINES	SW WELL GRADED SANDS WITH OR WITHOUT GRAVEL, LITTLE OR NO FINES
			SP POORLY GRADED SANDS WITH OR WITHOUT GRAVEL, LITTLE OR NO FINES
FINE-GRAINED SOILS MORE THAN HALF IS FINER THAN NO. 200 SIEVE	SILTS AND CLAYS LIQUID LIMIT 50% OR LESS	SM SILTY SANDS WITH OR WITHOUT GRAVEL	
		SC CLAYEY SANDS WITH OR WITHOUT GRAVEL	
		ML INORGANIC SILTS AND VERY FINE SANDS, ROCK FLOUR, SILTS WITH SANDS AND GRAVELS	
		CL INORGANIC CLAYS OF LOW TO MEDIUM PLASTICITY, CLAYS WITH SANDS AND GRAVELS, LEAN CLAYS	
	SILTS AND CLAYS LIQUID LIMIT GREATER THAN 50%	OL ORGANIC SILTS OR CLAYS OF LOW PLASTICITY	
		MH INORGANIC SILTS, MICACEOUS OR DIATOMACEOUS, FINE SANDY OR SILTY SOILS, ELASTIC SILTS	
		CH INORGANIC CLAYS OF HIGH PLASTICITY, FAT CLAYS	
		OH ORGANIC CLAYS OR CLAYS OF MEDIUM TO HIGH PLASTICITY	
	HIGHLY ORGANIC SOILS	PT PEAT AND OTHER HIGHLY ORGANIC SOILS	

**BEDDING SPACING DESCRIPTIONS**

THICKNESS/SPACING	DESCRIPTOR
GREATER THAN 10 FEET	MASSIVE
3 TO 10 FEET	VERY THICKLY BEDDED
1 TO 3 FEET	THICKLY BEDDED
3 1/4-INCH TO 1 FOOT	MODERATELY BEDDED
1 1/4-INCH TO 3 1/2-INCH	THINLY BEDDED
1/2-INCH TO 1 1/4-INCH	VERY THINLY BEDDED
LESS THAN 1/2-INCH	LAMINATED

**STRUCTURE DESCRIPTIONS**

CRITERIA	DESCRIPTION
ALTERNATING LAYERS OF VARYING MATERIAL OR COLOR WITH LAYERS AT LEAST 1/2-INCH THICK	STRATIFIED
ALTERNATING LAYERS OF VARYING MATERIAL OR COLOR WITH LAYERS LESS THAN 1/2-INCH THICK	LAMINATED
BREAKS ALONG DEFINITE PLANES OF FRACTURE WITH LITTLE RESISTANCE TO FRACTURING	FISSURED
FRACTURE PLANES APPEAR POLISHED OR GLOSSY, SOMETIMES STRIATED	SLICKENSIDED
COHESIVE SOIL THAT CAN BE BROKEN DOWN INTO SMALLER ANGULAR LUMPS WHICH RESIST FURTHER BREAKDOWN	BLOCKY
INCLUSION OF SMALL POCKETS OF DIFFERENT SOIL, SUCH AS SMALL LENSES OF SAND SCATTERED THROUGH A MASS OF CLAY	LENSED
SAME COLOR AND MATERIAL THROUGHOUT	HOMOGENOUS

**CEMENTATION/INDURATION DESCRIPTIONS**

FIELD TEST	DESCRIPTION
CRUMBLES OR BREAKS WITH HANDLING OR LITTLE FINGER PRESSURE	WEAKLY CEMENTED/INDURATED
CRUMBLES OR BREAKS WITH CONSIDERABLE FINGER PRESSURE	MODERATELY CEMENTED/INDURATED
WILL NOT CRUMBLE OR BREAK WITH FINGER PRESSURE	STRONGLY CEMENTED/INDURATED

**IGNEOUS/METAMORPHIC ROCK STRENGTH DESCRIPTIONS**

FIELD TEST	DESCRIPTION
MATERIAL CRUMBLES WITH BARE HAND	WEAK
MATERIAL CRUMBLES UNDER BLOWS FROM GEOLOGY HAMMER	MODERATELY WEAK
1/2-INCH INDENTATIONS WITH SHARP END FROM GEOLOGY HAMMER	MODERATELY STRONG
HAND-HELD SPECIMEN CAN BE BROKEN WITH ONE BLOW FROM GEOLOGY HAMMER	STRONG
HAND-HELD SPECIMEN CAN BE BROKEN WITH COUPLE BLOWS FROM GEOLOGY HAMMER	VERY STRONG
HAND-HELD SPECIMEN CAN BE BROKEN WITH MANY BLOWS FROM GEOLOGY HAMMER	EXTREMELY STRONG

**IGNEOUS/METAMORPHIC ROCK WEATHERING DESCRIPTIONS**

DEGREE OF DECOMPOSITION	FIELD RECOGNITION	ENGINEERING PROPERTIES
SOIL	DISCOLORED, CHANGED TO SOIL, FABRIC DESTROYED	EASY TO DIG
COMPLETELY WEATHERED	DISCOLORED, CHANGED TO SOIL, FABRIC MAINLY PRESERVED	EXCAVATED BY HAND OR RIPPING (Saprolite)
HIGHLY WEATHERED	DISCOLORED, HIGHLY FRACTURED, FABRIC ALTERED AROUND FRACTURES	EXCAVATED BY HAND OR RIPPING, WITH SLIGHT DIFFICULTY
MODERATELY WEATHERED	DISCOLORED, FRACTURES, INTACT ROCK-NOTICEABLY WEAKER THAN FRESH ROCK	EXCAVATED WITH DIFFICULTY WITHOUT EXPLOSIVES
SLIGHTLY WEATHERED	MAY BE DISCOLORED, SOME FRACTURES, INTACT ROCK-NOT NOTICEABLY WEAKER THAN FRESH ROCK	REQUIRES EXPLOSIVES FOR EXCAVATION, WITH PERMEABLE JOINTS AND FRACTURES
FRESH	NO DISCOLORATION, OR LOSS OF STRENGTH	REQUIRES EXPLOSIVES

**IGNEOUS/METAMORPHIC ROCK JOINT/FRACTURE DESCRIPTIONS**

FIELD TEST	DESCRIPTION
NO OBSERVED FRACTURES	UNFRACTURED/UNJOINTED
MAJORITY OF JOINTS/FRACTURES SPACED AT 1 TO 3 FOOT INTERVALS	SLIGHTLY FRACTURED/JOINTED
MAJORITY OF JOINTS/FRACTURES SPACED AT 4-INCH TO 1 FOOT INTERVALS	MODERATELY FRACTURED/JOINTED
MAJORITY OF JOINTS/FRACTURES SPACED AT 1-INCH TO 4-INCH INTERVALS WITH SCATTERED FRAGMENTED INTERVALS	INTENSELY FRACTURED/JOINTED
MAJORITY OF JOINTS/FRACTURES SPACED AT LESS THAN 1-INCH INTERVALS; MOSTLY RECOVERED AS CHIPS AND FRAGMENTS	VERY INTENSELY FRACTURED/JOINTED

**BORING/TRENCH LOG LEGEND**

PENETRATION RESISTANCE	SAND AND GRAVEL		SILT AND CLAY			
	RELATIVE DENSITY	BLOWS PER FOOT (SPT)*	BLOWS PER FOOT (MOD-CAL)*	CONSISTENCY	BLOWS PER FOOT (SPT)*	BLOWS PER FOOT (MOD-CAL)*
VERY LOOSE	0 - 4	0 - 6	VERY SOFT	0 - 2	0 - 3	0 - 0.25
LOOSE	5 - 10	7 - 16	SOFT	3 - 4	4 - 6	0.25 - 0.50
MEDIUM DENSE	11 - 30	17 - 48	MEDIUM STIFF	5 - 8	7 - 13	0.50 - 1.0
DENSE	31 - 50	49 - 79	STIFF	9 - 15	14 - 24	1.0 - 2.0
VERY DENSE	OVER 50	OVER 79	VERY STIFF	16 - 30	25 - 48	2.0 - 4.0
			HARD	OVER 30	OVER 48	OVER 4.0

\*NUMBER OF BLOWS OF 140 LB HAMMER FALLING 30 INCHES TO DRIVE LAST 12 INCHES OF AN 18-INCH DRIVE

**MOISTURE DESCRIPTIONS**

FIELD TEST	APPROX. DEGREE OF SATURATION, S (%)	DESCRIPTION
NO INDICATION OF MOISTURE; DRY TO THE TOUCH	S < 25	DRY
SLIGHT INDICATION OF MOISTURE	25 <= S < 50	DAMP
INDICATION OF MOISTURE; NO VISIBLE WATER	50 <= S < 75	MOIST
MINOR VISIBLE FREE WATER	75 <= S < 100	WET
VISIBLE FREE WATER	100	SATURATED

**QUANTITY DESCRIPTIONS**

APPROX. ESTIMATED PERCENT	DESCRIPTION
<5%	TRACE
5 - 10%	FEW
11 - 25%	LITTLE
26 - 50%	SOME
>50%	MOSTLY

**GRAVEL/COBBLE/BOULDER DESCRIPTIONS**

CRITERIA	DESCRIPTION
PASS THROUGH A 3-INCH SIEVE AND BE RETAINED ON A NO. 4 SIEVE (#4 TO #30)	GRAVEL
PASS A 12-INCH SQUARE OPENING AND BE RETAINED ON A 3-INCH SIEVE (3"-12")	COBBLE
WILL NOT PASS A 12-INCH SQUARE OPENING (>12")	BOULDER

Dream Inn Mixed-Use

Northwest Corner of W. Cliff Drive & Bay Street  
Santa Cruz, California

**KEY TO LOGS**

E8978-04-01

March 2017

Figure A1



**GEOCON**  
CONSULTANTS, INC.

6671 BRISA STREET - LIVERMORE, CA 94550  
PHONE 925.371.5900 - FAX 925.371.5915



DEPTH IN FEET	SAMPLE NO.	LITHOLOGY	GROUNDWATER	SOIL CLASS (USCS)	BORING B1		PENETRATION RESISTANCE (BLOWS/FT.)	DRY DENSITY (P.C.F.)	MOISTURE CONTENT (%)
					ELEV. (MSL.) _____	DATE COMPLETED <u>3/15/2017</u>			
					ENG./GEO. <u>JBM</u>	DRILLER <u>EGI</u>			
					EQUIPMENT <u>Mobile B53 w/ 8-inch HSA</u>	HAMMER TYPE <u>Downhole-Wireline</u>			
MATERIAL DESCRIPTION									
0					Approximately 2¾ inch AC				
1	B1-1.5			SC	Approximately 7 inches aggregate sub-base				
2					TERRACE DEPOSITS				
3	B1-2.5				Loose, moist, dark brown to brown, Silty to Clayey (f-m) SAND		10	114.4	16.3
4	B1-3				-pp=2½-3½				
5	B1-4				-orange-brown, less silt		14		
6	B1-4.5							113.4	18.1
7									
8									
9	B1-9			SP	Loose, damp to moist, light orange-brown, (f) SAND with trace fines		11		
10	B1-9.5								
11									
12									
13									
14	B1-14				PURISIMA FORMATION		80/11"		
15	B1-14.5				Light gray to tan, weak, highly weathered, SANDSTONE				
16					-excavates as (f) sand				
17									

Figure A2, Log of Boring B1, page 1 of 2



SAMPLE SYMBOLS		
	... SAMPLING UNSUCCESSFUL	
	... DISTURBED OR BAG SAMPLE	
	... STANDARD PENETRATION TEST	
	... CHUNK SAMPLE	
		... WATER TABLE OR SEEPAGE

NOTE: THE LOG OF SUBSURFACE CONDITIONS SHOWN HEREON APPLIES ONLY AT THE SPECIFIC BORING OR TRENCH LOCATION AND AT THE DATE INDICATED. IT IS NOT WARRANTED TO BE REPRESENTATIVE OF SUBSURFACE CONDITIONS AT OTHER LOCATIONS AND TIMES.



DEPTH IN FEET	SAMPLE NO.	LITHOLOGY	GROUNDWATER	SOIL CLASS (USCS)	<b>BORING B1</b>			PENETRATION RESISTANCE (BLOWS/FT.)	DRY DENSITY (P.C.F.)	MOISTURE CONTENT (%)
					ELEV. (MSL.) _____	DATE COMPLETED <u>3/15/2017</u>				
MATERIAL DESCRIPTION										
18										
19	B1-19-20							47		
20										
21										
22										
23										
24	B1-24-25							77/11"		
25										
26										
27										
28										
29	B1-28.5-29.5							50/5½"		
					-moderately to highly weathered -¾-inch siltstone nodule					
					END OF BORING AT APPROXIMATELY 29½ FEET GROUNDWATER INITIALLY ENCOUNTERED AT APPROXIMATELY 16 FEET BACKFILLED WITH COMPACTED CUTTINGS AND NEAT CEMENT AND CAPPED WITH CONCRETE					

Figure A2, Log of Boring B1, page 2 of 2



SAMPLE SYMBOLS					
	... SAMPLING UNSUCCESSFUL		... STANDARD PENETRATION TEST		... DRIVE SAMPLE (UNDISTURBED)
	... DISTURBED OR BAG SAMPLE		... CHUNK SAMPLE		... WATER TABLE OR SEEPAGE

NOTE: THE LOG OF SUBSURFACE CONDITIONS SHOWN HEREON APPLIES ONLY AT THE SPECIFIC BORING OR TRENCH LOCATION AND AT THE DATE INDICATED. IT IS NOT WARRANTED TO BE REPRESENTATIVE OF SUBSURFACE CONDITIONS AT OTHER LOCATIONS AND TIMES.

DEPTH IN FEET	SAMPLE NO.	LITHOLOGY	GROUNDWATER	SOIL CLASS (USCS)	<b>BORING B2</b>		PENETRATION RESISTANCE (BLOWS/FT.)	DRY DENSITY (P.C.F.)	MOISTURE CONTENT (%)
					ELEV. (MSL.) _____	DATE COMPLETED <u>3/15/2017</u>			
					ENG./GEO. <u>JBM</u>	DRILLER <u>EGI</u>			
					EQUIPMENT <u>Mobile B53 w/ 8-inch HSA</u>	HAMMER TYPE <u>Downhole-Wireline</u>			
<b>MATERIAL DESCRIPTION</b>									
0					Approximately 3 inches AC				
1				SC	Approximately 3½ inches aggregate sub-base				
2					<b>TERRACE DEPOSITS</b>				
3	B2-2.5				Medium dense, damp, orange-brown, Clayey (f-m) SAND		29	113.2	11.2
4	B2-3				-less clay, sand (f-c)		20		
5	B2-4								
6	B2-4.5								
7									
8									
9	B2-9-10				-loose, moist to wet, brown, sand (f)		10		
10									
11									
12									
13									
14	B2-14-15				<b>PURISIMA FORMATION</b>		74/10"		
15					Light gray to tan, weak, highly weathered, SANDSTONE				
16					-excavates as (f) sand				
17									

Figure A3, Log of Boring B2, page 1 of 2



SAMPLE SYMBOLS			
	... SAMPLING UNSUCCESSFUL		... STANDARD PENETRATION TEST
	... DISTURBED OR BAG SAMPLE		... CHUNK SAMPLE
			... WATER TABLE OR SEEPAGE

NOTE: THE LOG OF SUBSURFACE CONDITIONS SHOWN HEREON APPLIES ONLY AT THE SPECIFIC BORING OR TRENCH LOCATION AND AT THE DATE INDICATED. IT IS NOT WARRANTED TO BE REPRESENTATIVE OF SUBSURFACE CONDITIONS AT OTHER LOCATIONS AND TIMES.

DEPTH IN FEET	SAMPLE NO.	LITHOLOGY	GROUNDWATER	SOIL CLASS (USCS)	<b>BORING B2</b>			PENETRATION RESISTANCE (BLOWS/FT.)	DRY DENSITY (P.C.F.)	MOISTURE CONTENT (%)
					ELEV. (MSL.) _____	DATE COMPLETED	3/15/2017			
MATERIAL DESCRIPTION										
18										
19	B2-19-20									
20										
21										
22										
23										
	B2-23.5-24									

Figure A3, Log of Boring B2, page 2 of 2



SAMPLE SYMBOLS		
	... SAMPLING UNSUCCESSFUL	
	... DISTURBED OR BAG SAMPLE	

NOTE: THE LOG OF SUBSURFACE CONDITIONS SHOWN HEREON APPLIES ONLY AT THE SPECIFIC BORING OR TRENCH LOCATION AND AT THE DATE INDICATED. IT IS NOT WARRANTED TO BE REPRESENTATIVE OF SUBSURFACE CONDITIONS AT OTHER LOCATIONS AND TIMES.

DEPTH IN FEET	SAMPLE NO.	LITHOLOGY	GROUNDWATER	SOIL CLASS (USCS)	BORING B3		PENETRATION RESISTANCE (BLOWS/FT.)	DRY DENSITY (P.C.F.)	MOISTURE CONTENT (%)
					ELEV. (MSL.) _____	DATE COMPLETED <u>3/15/2017</u>			
					ENG./GEO. <u>JBM</u>	DRILLER <u>EGI</u>			
					EQUIPMENT <u>Mobile B53 w/ 8-inch HSA</u>	HAMMER TYPE <u>Downhole-Wireline</u>			
MATERIAL DESCRIPTION									
0					Approximately 1½ inches AC				
1	B3-1-5			SC	Approximately 4½ inches aggregate sub-base				
2					TERRACE DEPOSITS				
3	B3-2.5				Medium dense, damp, orange-brown, Clayey (f-m) SAND with trace gravels		22		
4	B3-3							110.9	10.2
5	B3-4				-speckled black and white, sand (f-c)		17		
6	B3-4.5							102.7	11.5
7									
8									
9	B3-9-10			SP	Medium dense, moist, gray-brown, (f) SAND with trace clay		11		
10									
11									
12			▼						
13									
14	B3-14-15				PURISIMA FORMATION Dark gray, weak, highly weathered, SANDSTONE -excavates as silty (f) sand		57		
15									
16									
17									

Figure A4, Log of Boring B3, page 1 of 2



SAMPLE SYMBOLS			
	... SAMPLING UNSUCCESSFUL		... STANDARD PENETRATION TEST
	... DISTURBED OR BAG SAMPLE		... CHUNK SAMPLE
			... WATER TABLE OR SEEPAGE

NOTE: THE LOG OF SUBSURFACE CONDITIONS SHOWN HEREON APPLIES ONLY AT THE SPECIFIC BORING OR TRENCH LOCATION AND AT THE DATE INDICATED. IT IS NOT WARRANTED TO BE REPRESENTATIVE OF SUBSURFACE CONDITIONS AT OTHER LOCATIONS AND TIMES.

DEPTH IN FEET	SAMPLE NO.	LITHOLOGY	GROUNDWATER	SOIL CLASS (USCS)	<b>BORING B3</b>			PENETRATION RESISTANCE (BLOWS/FT.)	DRY DENSITY (P.C.F.)	MOISTURE CONTENT (%)	
					ELEV. (MSL.) _____	DATE COMPLETED	3/15/2017				ENG./GEO. <u>JBM</u>
MATERIAL DESCRIPTION											
18		[Lithology Pattern]			-moderately to highly weathered						
19	B3-19-20								78/10"		
20											
21											
22											
23											
24	B2-23.5-24.5									50/5"	
					END OF BORING AT APPROXIMATELY 24½ FEET GROUNDWATER INITIALLY ENCOUNTERED AT APPROXIMATELY 13 FEET BACKFILLED WITH COMPACTED CUTTINGS AND NEAT CEMENT AND CAPPED WITH CONCRETE						

Figure A4, Log of Boring B3, page 2 of 2



SAMPLE SYMBOLS		
<input type="checkbox"/>	... SAMPLING UNSUCCESSFUL	<input checked="" type="checkbox"/>
<input checked="" type="checkbox"/>	... DISTURBED OR BAG SAMPLE	<input checked="" type="checkbox"/>
<input type="checkbox"/>	... STANDARD PENETRATION TEST	<input checked="" type="checkbox"/>
<input checked="" type="checkbox"/>	... CHUNK SAMPLE	<input checked="" type="checkbox"/>
<input type="checkbox"/>	... DRIVE SAMPLE (UNDISTURBED)	<input checked="" type="checkbox"/>
<input type="checkbox"/>	... WATER TABLE OR SEEPAGE	<input checked="" type="checkbox"/>

NOTE: THE LOG OF SUBSURFACE CONDITIONS SHOWN HEREON APPLIES ONLY AT THE SPECIFIC BORING OR TRENCH LOCATION AND AT THE DATE INDICATED. IT IS NOT WARRANTED TO BE REPRESENTATIVE OF SUBSURFACE CONDITIONS AT OTHER LOCATIONS AND TIMES.

DEPTH IN FEET	SAMPLE NO.	LITHOLOGY	GROUNDWATER	SOIL CLASS (USCS)	<b>BORING B4</b>		PENETRATION RESISTANCE (BLOWS/FT.)	DRY DENSITY (P.C.F.)	MOISTURE CONTENT (%)
					ELEV. (MSL.) _____	DATE COMPLETED <u>3/15/2017</u>			
<b>MATERIAL DESCRIPTION</b>									
0						Approximately 1½ inches AC			
1				SC		Approximately 5½ inches aggregate sub-base			
2						<b>TERRACE DEPOSITS</b> Medium dense, damp, orange-brown, Clayey (f-m) SAND -moderately cemented			
3	B4-2.5 B4-3						20	105.2	18.6
4	B4-4.5					-loose	10		
5									
6									
7									
8									
9	B4-9-10					-medium dense, sand (f)	13		
10									
11									
12									
13									
14	B4-13.5-14.5					<b>PURISIMA FORMATION</b> Brown-gray, weak, highly weathered, SANDSTONE -excavates as (f) sand	50/4"		
15									
16						-dark gray			
17									

Figure A5, Log of Boring B4, page 1 of 2



SAMPLE SYMBOLS			
	... SAMPLING UNSUCCESSFUL		... STANDARD PENETRATION TEST
	... DISTURBED OR BAG SAMPLE		... CHUNK SAMPLE
			... WATER TABLE OR SEEPAGE

NOTE: THE LOG OF SUBSURFACE CONDITIONS SHOWN HEREON APPLIES ONLY AT THE SPECIFIC BORING OR TRENCH LOCATION AND AT THE DATE INDICATED. IT IS NOT WARRANTED TO BE REPRESENTATIVE OF SUBSURFACE CONDITIONS AT OTHER LOCATIONS AND TIMES.







DEPTH IN FEET	SAMPLE NO.	LITHOLOGY	GROUNDWATER	SOIL CLASS (USCS)	<b>BORING B4</b>		PENETRATION RESISTANCE (BLOWS/FT.)	DRY DENSITY (P.C.F.)	MOISTURE CONTENT (%)	
					ELEV. (MSL.) _____	DATE COMPLETED <u>3/15/2017</u>				ENG./GEO. <u>JBM</u>
MATERIAL DESCRIPTION										
18	B4-18.5-19.5				-moderately to highly weathered			50/6"		
19										
					END OF BORING AT APPROXIMATELY 19½ FEET GROUNDWATER INITIALLY ENCOUNTERED AT APPROXIMATELY 13 FEET BACKFILLED WITH COMPACTED CUTTINGS AND NEAT CEMENT AND CAPPED WITH CONCRETE					

Figure A5, Log of Boring B4, page 2 of 2

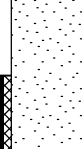

SAMPLE SYMBOLS			
	... SAMPLING UNSUCCESSFUL		... STANDARD PENETRATION TEST
	... DISTURBED OR BAG SAMPLE		... CHUNK SAMPLE
			... WATER TABLE OR SEEPAGE

NOTE: THE LOG OF SUBSURFACE CONDITIONS SHOWN HEREON APPLIES ONLY AT THE SPECIFIC BORING OR TRENCH LOCATION AND AT THE DATE INDICATED. IT IS NOT WARRANTED TO BE REPRESENTATIVE OF SUBSURFACE CONDITIONS AT OTHER LOCATIONS AND TIMES.

APPENDIX

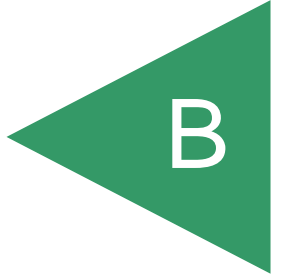



**APPENDIX B  
LABORATORY TESTING**

Laboratory tests were performed in accordance with generally accepted test methods of the American Society for Testing and Materials (ASTM) or other suggested procedures. Selected samples were tested for in-situ dry density and moisture content, grain size distribution, plasticity, shear strength and screening-level corrosion parameters. The results of our testing are summarized in tabular format below and the following figures. In-situ dry density and moisture content test results are included on the boring logs in Appendix A.

**TABLE B-I  
SUMMARY OF LABORATORY ATTERBERG LIMITS TEST RESULTS  
ASTM D 4318**

Sample No.	Liquid Limit	Plastic Limit	Plasticity Index
B1-1-5	27	15	11

**TABLE B-II  
SUMMARY OF LABORATORY FINES CONTENT TEST RESULTS  
ASTM D 2216**

Boring No.	Sample Depth (ft.)	% Passing No. 200 Sieve
B1	2.5	40

**TABLE B-III  
SUMMARY OF LABORATORY DIRECT SHEAR TEST RESULTS  
ASTM D 3080**

Boring No.	Sample Depth (feet)	Initial Average Dry Density (pcf)	Initial Average Moisture Content (%)	Cohesion (psf)	Angle of Shear Resistance (degrees)
B1	9.5	82.7	32.4	450	24
B2	4.5	102.1	13.1	480	23
B3	4.5	102.7	11.5	300	32

**APPENDIX B  
LABORATORY TESTING (CONTINUED)**

**TABLE B-IV  
SUMMARY OF SCREENING-LEVEL CORROSION PARAMETERS  
AASHTO T291 (CHLORIDE)  
CALIFORNIA TEST NO. 643 (pH AND RESISTIVITY) AND 417 (SULFATE)**

<b>Sample No.</b>	<b>pH</b>	<b>Minimum Resistivity (ohm-cm)</b>	<b>Chloride (ppm)</b>	<b>Water-Soluble Sulfate (ppm)</b>	<b>Sulfate Exposure</b>
B1-1-5	pending	pending	pending	pending	pending
B4-13.5-14.5	pending	pending	pending	pending	pending

Notes:

1. Caltrans considers a site corrosive to foundation elements if one or more of the following conditions exist for the representative soil samples at the site:
  - The pH is equal to or less than 5.5.
  - Chloride concentration is equal to or greater than 500 parts per million (ppm) or 0.05%.
  - Sulfate concentration is equal to or greater than 2,000 ppm (0.2%)
  
2. Per 2016 CBC Section 1904, which refers to ACI 318 Chapter 19, Table 19.3.1.1, Type II cement may be used for S0 or S1 exposure classes i.e. where sulfate levels are below 2,000 ppm (0.2%).

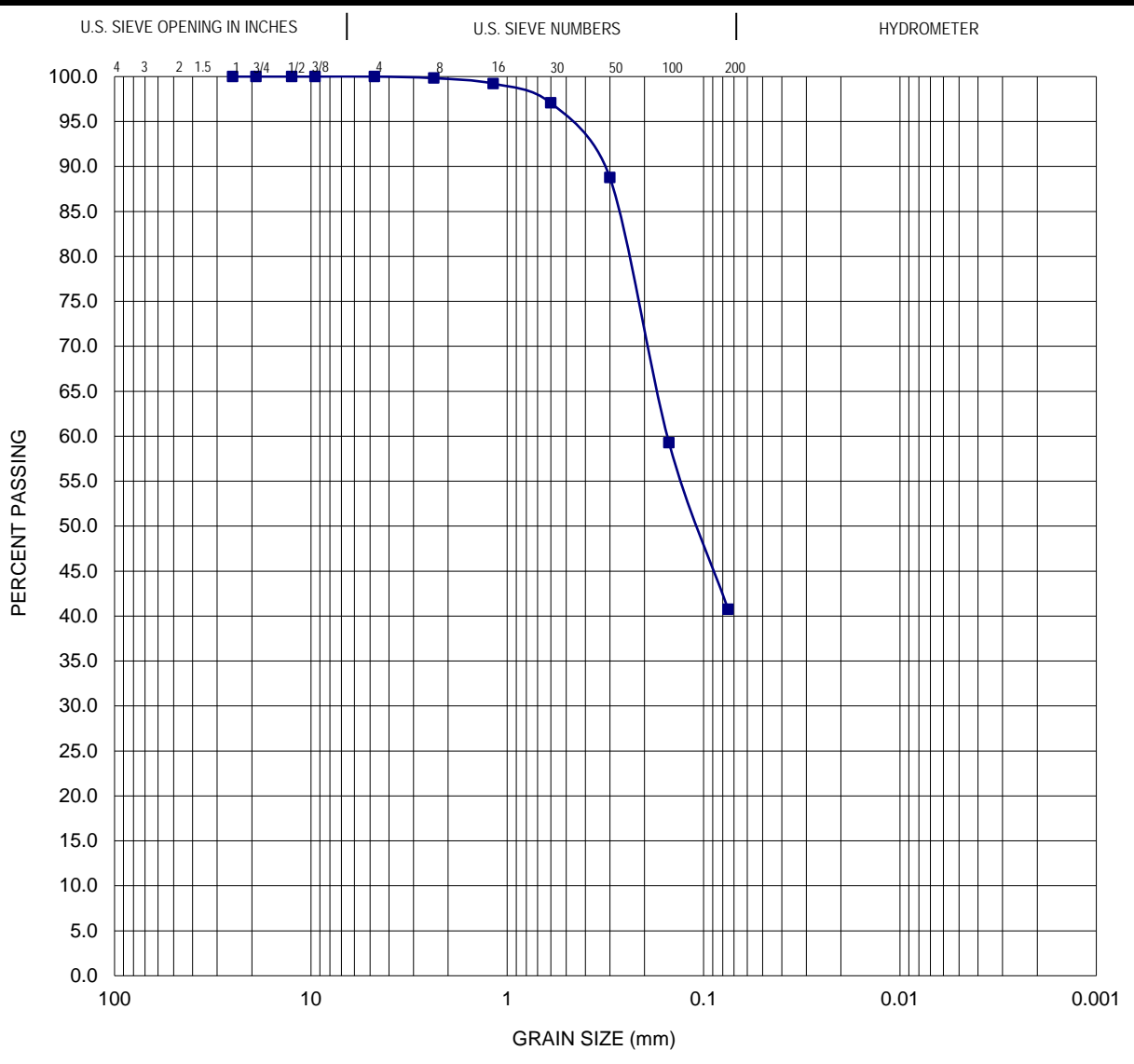

COBBLES	GRAVEL		SAND			SILT OR CLAY
	coarse	fine	coarse	medium	fine	

**Boring:** B2  
**Depth To Sample:** 2.5'

**Sieve Date:** 3/24/17  
**Tested and Computed by:** FG

**Test Data**

Sieve Number	1 1/2"	1"	3/4"	1/2"	3/8"	#4	#8	#16	#30	#50	#100	#200
% Passing	100	100	100	100	100	100	99.8	99.2	97.1	88.8	59.3	40.7



Geocon Consultants, Inc.  
 6671 Brisa Street  
 Livermore, CA 94550  
 Telephone: (925) 371-5900  
 Fax: (925) 371-5915

**Particle Size Analysis - ASTM D422**

**Project:** Ensemble - Dream Inn Santa Cruz  
**Location:** Santa Cruz, CA  
**Project No.:** E8978-04-01

**Figure B1**

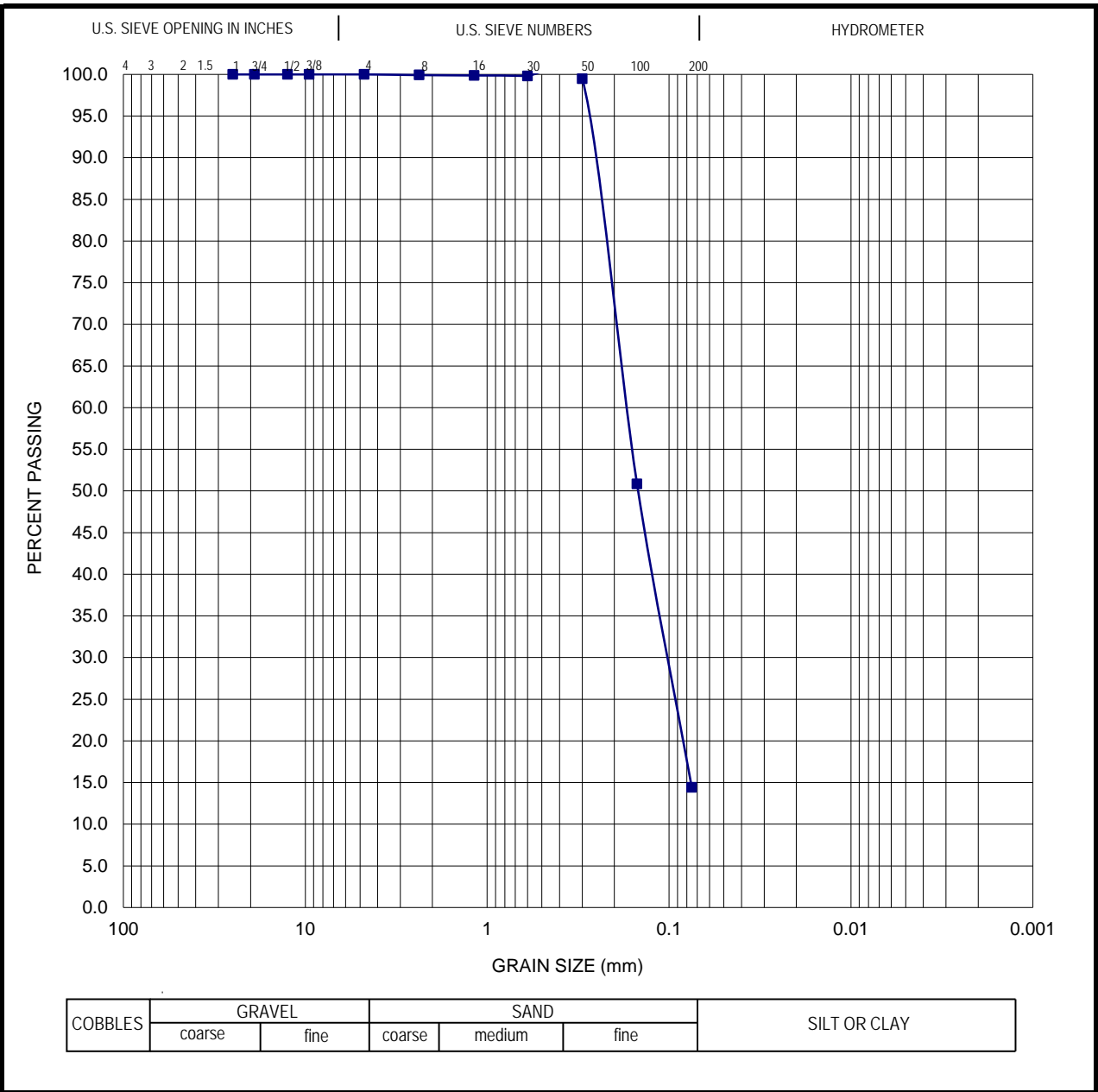

**Boring:** B2

**Sieve Date:** 3/24/17

**Depth To Sample:** 9'-10'

**Tested and Computed by:** FG

**Test Data**

Sieve Number	1 1/2"	1"	3/4"	1/2"	3/8"	#4	#8	#16	#30	#50	#100	#200
% Passing	100	100	100	100	100	100	99.9	99.9	99.8	99.5	50.8	14.4



Geocon Consultants, Inc.  
 6671 Brisa Street  
 Livermore, CA 94550  
 Telephone: (925) 371-5900  
 Fax: (925) 371-5915

**Particle Size Analysis - ASTM D422**

**Project:** Ensemble - Dream Inn Santa Cruz  
**Location:** Santa Cruz, CA  
**Project No.:** E8978-04-01

**Figure B2**

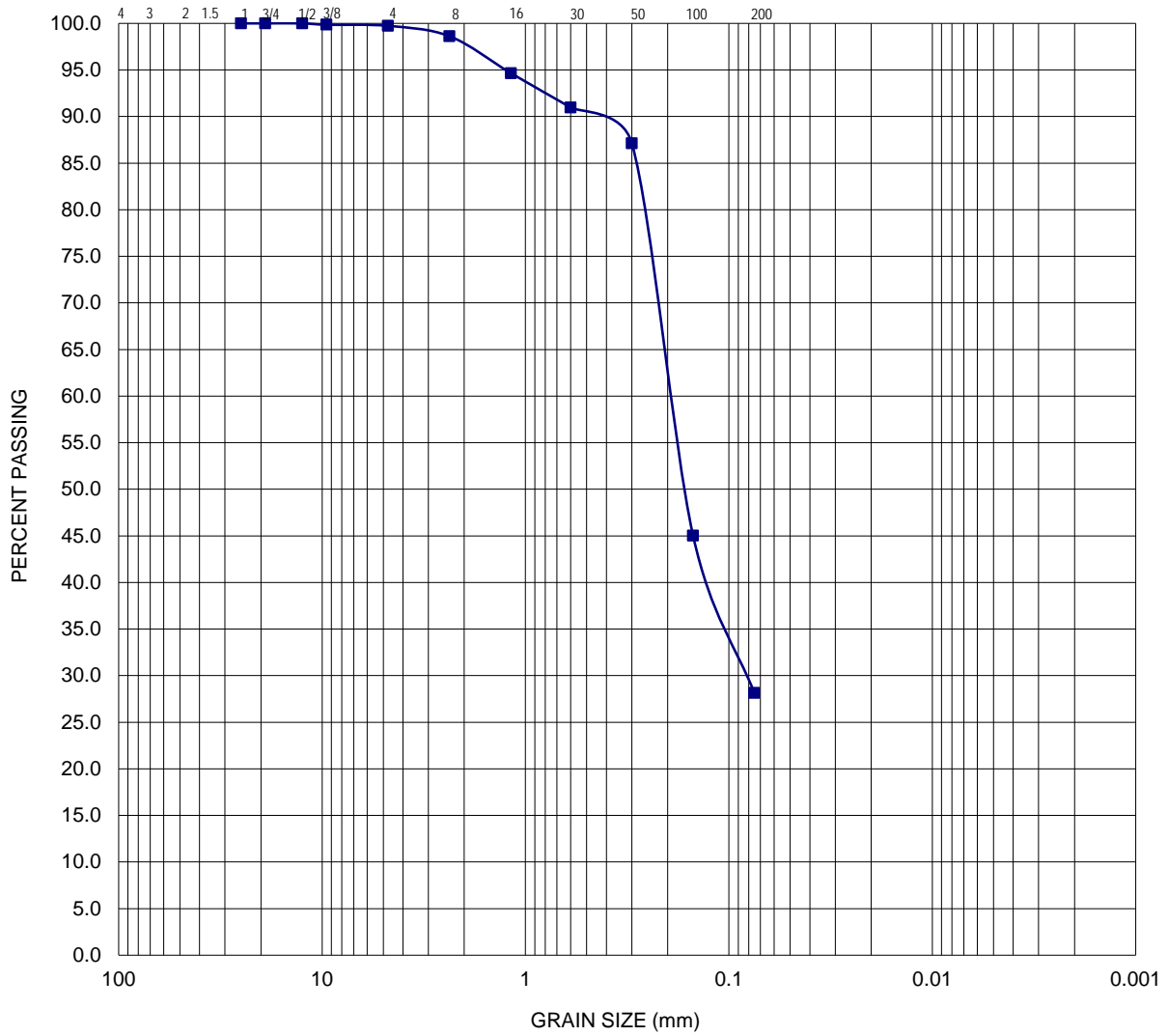

COBBLES	GRAVEL		SAND			SILT OR CLAY
	coarse	fine	coarse	medium	fine	

**Boring:** B3

**Sieve Date:** 3/24/17

**Depth To Sample:** 4'

**Tested and Computed by:** FG

**Test Data**

Sieve Number	1 1/2"	1"	3/4"	1/2"	3/8"	#4	#8	#16	#30	#50	#100	#200
% Passing	100	100	100	100	99.9	99.7	98.6	94.7	91.0	87.1	45.0	28.1



Geocon Consultants, Inc.  
 6671 Brisa Street  
 Livermore, CA 94550  
 Telephone: (925) 371-5900  
 Fax: (925) 371-5915

**Particle Size Analysis - ASTM D422**

**Project:** Ensemble - Dream Inn Santa Cruz  
**Location:** Santa Cruz, CA  
**Project No.:** E8978-04-01

**Figure B3**

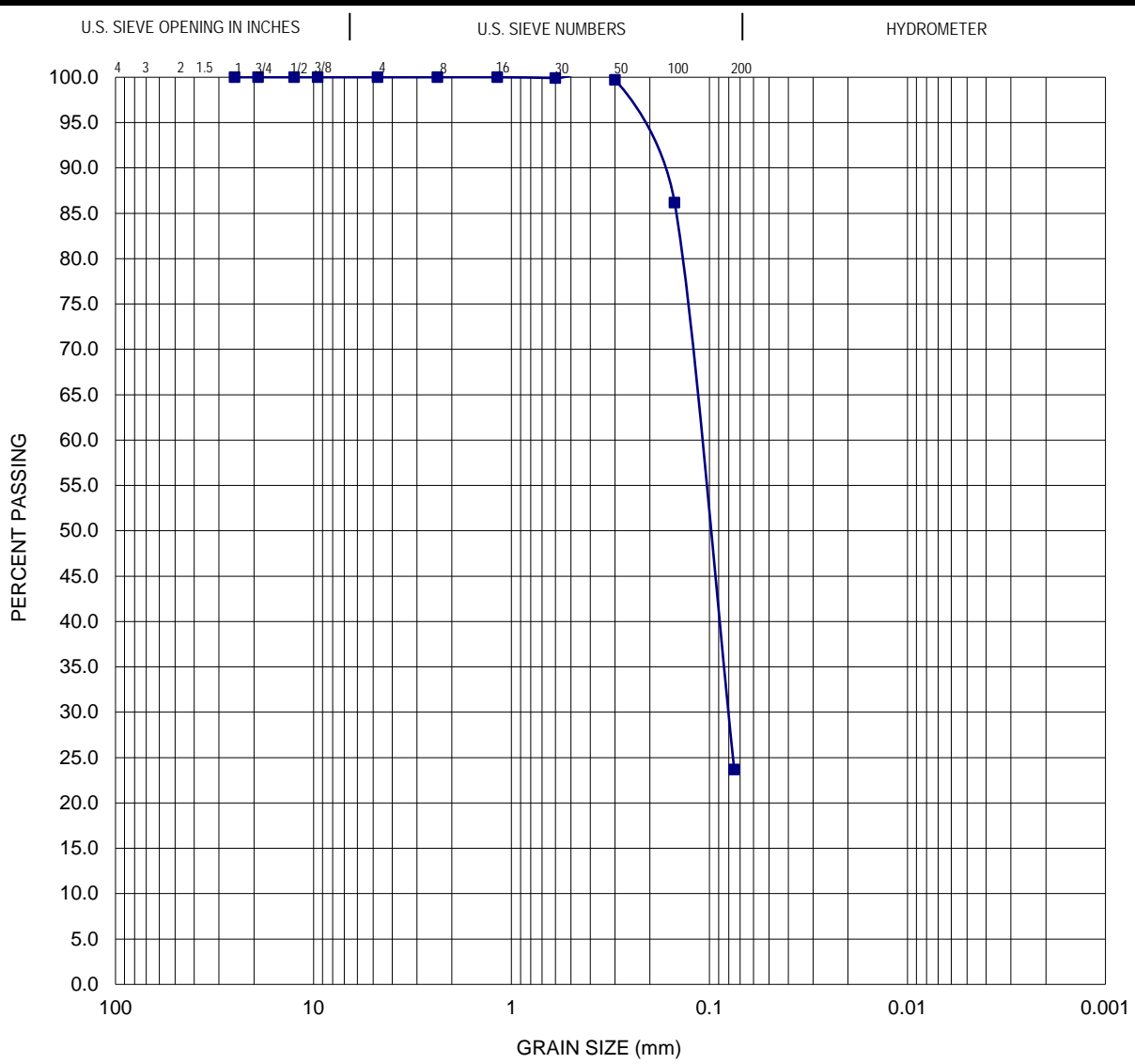

COBBLES	GRAVEL		SAND			SILT OR CLAY
	coarse	fine	coarse	medium	fine	

**Boring:** B3  
**Depth To Sample:** 14'-15'  
**Sieve Date:** 3/24/17  
**Tested and Computed by:** FG

**Test Data**

Sieve Number	1 1/2"	1"	3/4"	1/2"	3/8"	#4	#8	#16	#30	#50	#100	#200
% Passing	100	100	100	100	100	100	100	100	99.9	99.7	86.2	23.7



Geocon Consultants, Inc.  
 6671 Brisa Street  
 Livermore, CA 94550  
 Telephone: (925) 371-5900  
 Fax: (925) 371-5915

**Particle Size Analysis - ASTM D422**

**Project:** Ensemble - Dream Inn Santa Cruz  
**Location:** Santa Cruz, CA  
**Project No.:** E8978-04-01

**Figure B4**

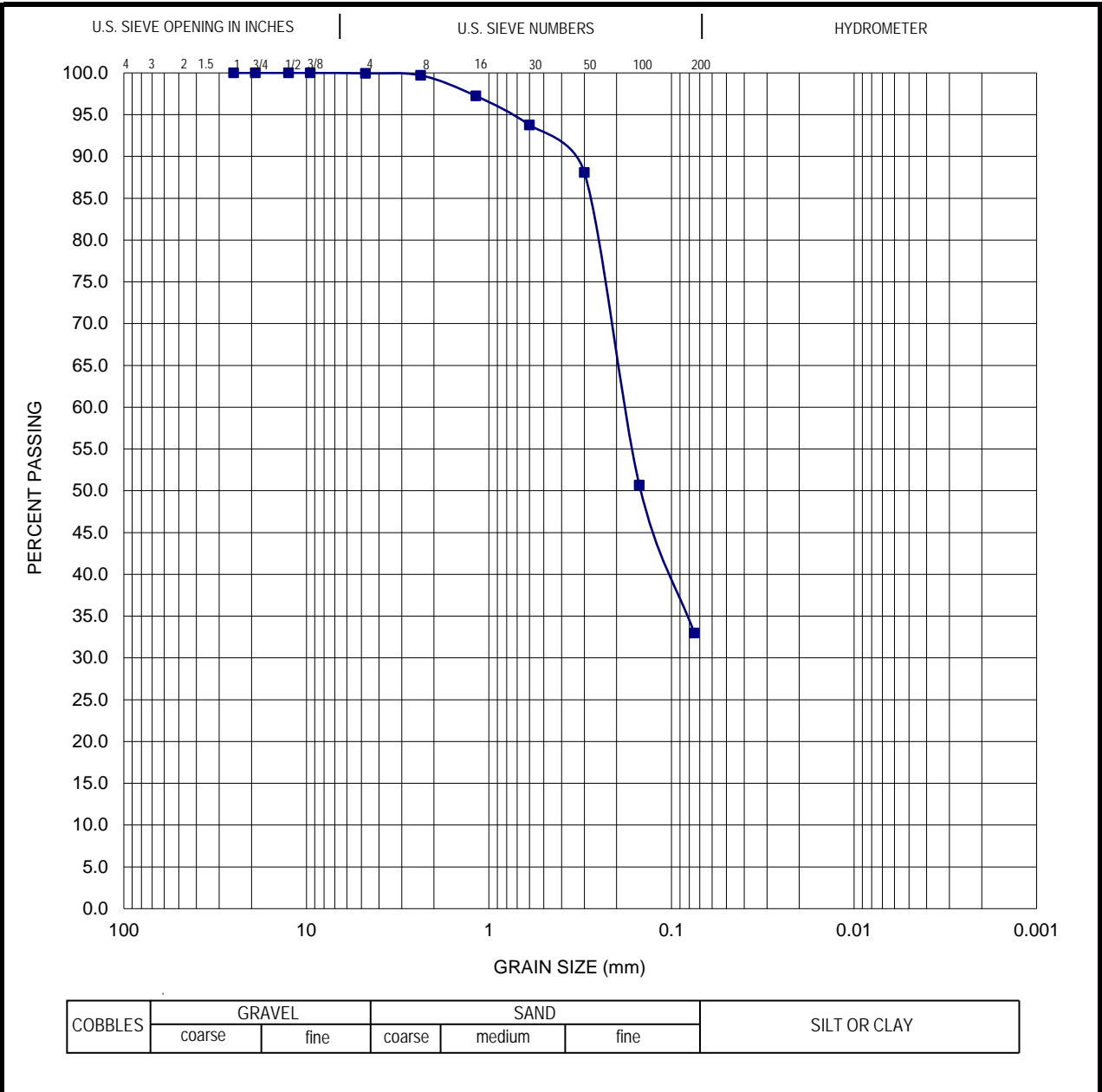

COBBLES	GRAVEL		SAND			SILT OR CLAY
	coarse	fine	coarse	medium	fine	

**Boring:** B4  
**Depth To Sample:** 4'-5'

**Sieve Date:** 3/24/17  
**Tested and Computed by:** FG

**Test Data**

Sieve Number	1 1/2"	1"	3/4"	1/2"	3/8"	#4	#8	#16	#30	#50	#100	#200
% Passing	100	100	100	100	100	99.9	99.7	97.2	93.8	88.1	50.7	33.0



Geocon Consultants, Inc.  
 6671 Brisa Street  
 Livermore, CA 94550  
 Telephone: (925) 371-5900  
 Fax: (925) 371-5915

**Particle Size Analysis - ASTM D422**  
**Project:** Ensemble - Dream Inn Santa Cruz  
**Location:** Santa Cruz, CA  
**Project No.:** E8978-04-01

**Figure B5**

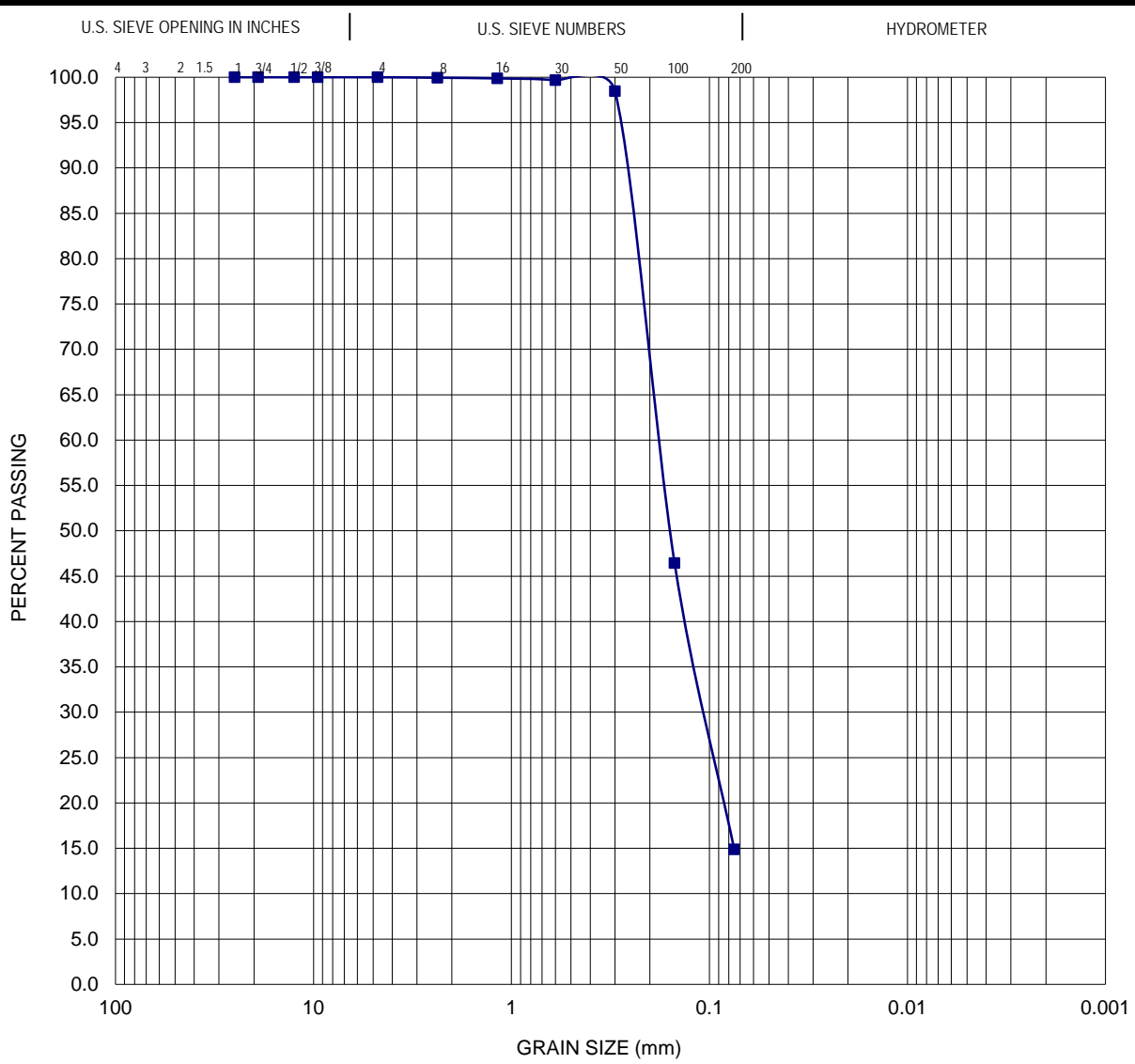

COBBLES	GRAVEL		SAND			SILT OR CLAY
	coarse	fine	coarse	medium	fine	

**Boring:** B4

**Sieve Date:** 3/24/17

**Depth To Sample:** 9'-10'

**Tested and Computed by:** FG

**Test Data**

Sieve Number	1 1/2"	1"	3/4"	1/2"	3/8"	#4	#8	#16	#30	#50	#100	#200
% Passing	100	100	100	100	100	100	99.9	99.9	99.7	98.5	46.4	14.9



Geocon Consultants, Inc.  
 6671 Brisa Street  
 Livermore, CA 94550  
 Telephone: (925) 371-5900  
 Fax: (925) 371-5915

**Particle Size Analysis - ASTM D422**

**Project:** Ensemble - Dream Inn Santa Cruz  
**Location:** Santa Cruz, CA  
**Project No.:** E8978-04-01

**Figure B6**



**APPENDIX C**  
**LOGS OF SOIL BORINGS BY OTHERS**

PROJECT:

**COAST HOTEL**  
Santa Cruz, California

# Log of Boring B-2

Boring location: See Site Plan, Figure 2

Logged by: M. Stobbe

Date started: 6/1/04

Date finished: 6/2/04

Drilling method: Rotary Wash

Hammer weight/drop: 140 lbs./30-inches

Hammer type: Rope and Cathead

LABORATORY TEST DATA

Sampler: Sprague & Henwood (S&H), Standard Penetration Test (SPT), Pitcher Barrel, HQ Diamond Core

DEPTH (feet)	SAMPLES			LITHOLOGY	MATERIAL DESCRIPTION	Coring Rate (ft/min)	RQD, %	Shear Strength Lbs/Sq Ft	Fines %	Natural Moisture Content, %	Dry Density Lbs/Cu Ft
	Sampler Type	Sample	SPT N-Value <sup>1</sup>								
					Ground Surface Elevation: 48 feet <sup>2</sup>						
1				ML	1.5-inches Asphaltic Concrete						
2				ML	GRAVEL with SAND yellow brown, moist, with silt (Aggregate Baserock)						
3	S&H		22	SC	SANDY SILT (ML) dark brown, moist, with clay						
4				SC	CLAYEY SAND (SC) orange brown, medium dense, moist						
5				SM	SILTY SAND (SM) tan and yellow-brown, medium dense, moist						
6	S&H		23						17.9	8.7	114
7					grading finer						
9	PT			SM							
12					▽ (06/02/04)						
15	SPT		56		SANDSTONE olive tan, very little fracturing, low to moderately hard, friable to weak, deeply weathered						
19					grading to dark olive green, moderately weathered						
23					no pressure						
24	CORE	•				2					
25						4					
26						3.5					
27						3					
28						3					

GEOTECH LOG WITH CORING/DRILLING RATE 393501.GPJ TR.GDT 6/29/04

Boring terminated at 26.5 feet below ground surface.  
Boring backfilled with cement grout by the tremie method. Asphalt surface patch.  
Groundwater encountered at a depth of 12 feet during drilling.

<sup>1</sup> S&H blow counts converted to SPT N-Values using a factor of 0.6.  
<sup>2</sup> Topographic elevations taken from plan provided by Homberger Worstell.

**Treadwell & Rollo**

Project No.: 3935.01

Figure:

A-2

PROJECT:

**COAST HOTEL**  
Santa Cruz, California

# Log of Boring B-3

Boring location: See Site Plan, Figure 2

Logged by: M. Stobbe

Date started: 6/2/04

Date finished: 6/2/04

Drilling method: Rotary Wash

Hammer weight/drop: 140 lbs./30-inches

Hammer type: Rope and Cathead

LABORATORY TEST DATA

Sampler: Sprague & Henwood (S&H), Standard Penetration Test (SPT), Pitcher Barrel

DEPTH (feet)	SAMPLES			LITHOLOGY	MATERIAL DESCRIPTION	Coring Rate (ft/min)	RQD, %	Shear Strength Lbs/Sq Ft	Fines %	Natural Moisture Content, %	Dry Density Lbs/Cu Ft
	Sampler Type	Sample	SPT N-Value <sup>1</sup>								
Ground Surface Elevation: 47 feet <sup>2</sup>											
1	S&H		14	SM	2-inches Asphalt Pavement						
2				SC	SAND with GRAVEL (SM) yellow brown with silt (decomposed granite base)						
3					CLAYEY SAND (SC) medium dense, moist, with trace roots						
4					CLAYEY SAND (SC) orange brown, medium dense, moist						
5	S&H		20	SC						12.5	117
6											
7											
8											
9					SAND with SILT (SM-SP) brown, medium dense, wet						
10	PT		16	SM-SP					7.1	35.3	
11											
12	SPT								8.7	31.0	
13											
14					SANDSTONE light olive tan, friable, very little fracturing, low to moderately hard, weak, deeply weathered						
15					grading dark olive green						
16											
17											
18	CORE					2.5					
19						3					
20						3.5					
21						2					
22	PT				moderately weathered	NA					
23											
24											
25											
26											
27											
28											
29											
30											

GEOTECH LOG WITH CORING/DRILLING RATE 393501.GPJ TR.GDT 6/29/04

Boring terminated at 23 feet below ground surface.  
Boring backfilled with cement grout.  
Groundwater not encountered during drilling.

<sup>1</sup> S&H blow counts converted to SPT N-Values using a factor of 0.6.  
<sup>2</sup> Topographic elevations taken from plan provided by Homberger Worstell.

**Treadwell & Rollo**

Project No.: 3935.01

Figure:

A-3

## UNIFIED SOIL CLASSIFICATION SYSTEM

Major Divisions	Symbols	Typical Names
<b>Coarse-Grained Soils</b> (more than half of soil > no. 200 sieve size)	<b>Gravels</b> (More than half of coarse fraction > no. 4 sieve size)	<b>GW</b> Well-graded gravels or gravel-sand mixtures, little or no fines
		<b>GP</b> Poorly-graded gravels or gravel-sand mixtures, little or no fines
		<b>GM</b> Silty gravels, gravel-sand-silt mixtures
		<b>GC</b> Clayey gravels, gravel-sand-clay mixtures
	<b>Sands</b> (More than half of coarse fraction < no. 4 sieve size)	<b>SW</b> Well-graded sands or gravelly sands, little or no fines
		<b>SP</b> Poorly-graded sands or gravelly sands, little or no fines
		<b>SM</b> Silty sands, sand-silt mixtures
		<b>SC</b> Clayey sands, sand-clay mixtures
<b>Fine-Grained Soils</b> (more than half of soil < no. 200 sieve size)	<b>Silts and Clays</b> LL = < 50	<b>ML</b> Inorganic silts and clayey silts of low plasticity, sandy silts, gravelly silts
		<b>CL</b> Inorganic clays of low to medium plasticity, gravelly clays, sandy clays, lean clays
		<b>OL</b> Organic silts and organic silt-clays of low plasticity
	<b>Silts and Clays</b> LL = > 50	<b>MH</b> Inorganic silts of high plasticity
		<b>CH</b> Inorganic clays of high plasticity, fat clays
		<b>OH</b> Organic silts and clays of high plasticity
<b>Highly Organic Soils</b>	<b>PT</b>	Peat and other highly organic soils

### SAMPLE DESIGNATIONS/SYMBOLS

GRAIN SIZE CHART		
Classification	Range of Grain Sizes	
	U.S. Standard Sieve Size	Grain Size in Millimeters
Boulders	Above 12"	Above 305
Cobbles	12" to 3"	305 to 76.2
Gravel coarse fine	3" to No. 4	76.2 to 4.76
	3" to 3/4"	76.2 to 19.1
	3/4" to No. 4	19.1 to 4.76
Sand coarse medium fine	No. 4 to No. 200	4.76 to 0.074
	No. 4 to No. 10	4.76 to 2.00
	No. 10 to No. 40	2.00 to 0.420
	No. 40 to No. 200	0.420 to 0.074
Silt and Clay	Below No. 200	Below 0.074

- Sample taken with Sprague & Henwood split-barrel sampler with a 3.0-inch outside diameter and a 2.43-inch inside diameter. Darkened area indicates soil recovered
- Classification sample taken with Standard Penetration Test sampler
- Undisturbed sample taken with thin-walled tube
- Disturbed sample
- Sampling attempted with no recovery
- Core sample
- Analytical laboratory sample
- Sample taken with Direct Push sampler

- Unstabilized groundwater level
- Stabilized groundwater level

### SAMPLER TYPE

- |   |  |
|---|--|
| <ul style="list-style-type: none"> <li><b>C</b> Core barrel</li> <li><b>CA</b> California split-barrel sampler with 2.5-inch outside diameter and a 1.93-inch inside diameter</li> <li><b>D&amp;M</b> Dames &amp; Moore piston sampler using 2.5-inch outside diameter, thin-walled tube</li> <li><b>O</b> Osterberg piston sampler using 3.0-inch outside diameter, thin-walled Shelby tube</li> </ul> | <ul style="list-style-type: none"> <li><b>PT</b> Pitcher tube sampler using 3.0-inch outside diameter, thin-walled Shelby tube</li> <li><b>S&amp;H</b> Sprague &amp; Henwood split-barrel sampler with a 3.0-inch outside diameter and a 2.43-inch inside diameter</li> <li><b>SPT</b> Standard Penetration Test (SPT) split-barrel sampler with a 2.0-inch outside diameter and a 1.5-inch inside diameter</li> <li><b>ST</b> Shelby Tube (3.0-inch outside diameter, thin-walled tube) advanced with hydraulic pressure</li> </ul> |
|---|--|

**COAST HOTEL**  
Sata Cruz, California

### CLASSIFICATION CHART

Treadwell & Rollo

**I FRACTURING**

Intensity	Size of Pieces in Feet
Very little fractured	Greater than 4.0
Occasionally fractured	1.0 to 4.0
Moderately fractured	0.5 to 1.0
Closely fractured	0.1 to 0.5
Intensely fractured	0.05 to 0.1
Crushed	Less than 0.05

**II HARDNESS**

1. **Soft** - reserved for plastic material alone.
2. **Low hardness** - can be gouged deeply or carved easily with a knife blade.
3. **Moderately hard** - can be readily scratched by a knife blade; scratch leaves a heavy trace of dust and is readily visible after the powder has been blown away.
4. **Hard** - can be scratched with difficulty; scratch produced a little powder and is often faintly visible.
5. **Very hard** - cannot be scratched with knife blade; leaves a metallic streak.

**III STRENGTH**

1. **Plastic** or very low strength.
2. **Friable** - crumbles easily by rubbing with fingers.
3. **Weak** - an unfractured specimen of such material will crumble under light hammer blows.
4. **Moderately strong** - specimen will withstand a few heavy hammer blows before breaking.
5. **Strong** - specimen will withstand a few heavy ringing hammer blows and will yield with difficulty only dust and small flying fragments.
6. **Very strong** - specimen will resist heavy ringing hammer blows and will yield with difficulty only dust and small flying fragments.

**IV WEATHERING** - The physical and chemical disintegration and decomposition of rocks and minerals by natural processes such as oxidation, reduction, hydration, solution, carbonation, and freezing and thawing.

- D. Deep** - moderate to complete mineral decomposition; extensive disintegration; deep and thorough discoloration; many fractures, all extensively coated or filled with oxides, carbonates and/or clay or silt.
- M. Moderate** - slight change or partial decomposition of minerals; little disintegration; cementation little to unaffected. Moderate to occasionally intense discoloration. Moderately coated fractures.
- L. Little** - no megascopic decomposition of minerals; little of no effect on normal cementation. Slight and intermittent, or localized discoloration. Few stains on fracture surfaces.
- F. Fresh** - unaffected by weathering agents. No disintegration or discoloration. Fractures usually less numerous than joints.

**ADDITIONAL COMMENTS:**

**V CONSOLIDATION OF SEDIMENTARY ROCKS:** usually determined from unweathered samples. Largely dependent on cementation.

- U = unconsolidated
- P = poorly consolidated
- M = moderately consolidated
- W = well consolidated

**VI BEDDING OF SEDIMENTARY ROCKS**

Splitting Property	Thickness	Stratification
Massive	Greater than 4.0 ft.	very thick-bedded
Blocky	2.0 to 4.0 ft.	thick bedded
Slabby	0.2 to 2.0 ft.	thin bedded
Flaggy	0.05 to 0.2 ft.	very thin-bedded
Shaly or platy	0.01 to 0.05 ft.	laminated
Papery	less than 0.01	thinly laminated

COAST HOTEL  
Santa Cruz, California

**PHYSICAL PROPERTIES CRITERIA  
FOR ROCK DESCRIPTIONS**



## LIST OF REFERENCES

- American Concrete Institute (ACI), *Building Code Requirements for Structural Concrete and Commentary*, ACI 318-14, 2014.
- Brabb, E.E., *Geologic Map of Santa Cruz County, California*, United States Geological Survey (USGS) Open File Report No. 97-489, 1997.
- California Building Standards Commission, *2016 California Building Code*, based on *2015 International Building Code* by International Code Council.
- California Department of Transportation, *Corrosion Guidelines*, Version 2.1, January 2015.
- California Department of Transportation, *Highway Design Manual*, Sixth Edition, July 2008.
- California Emergency Management Agency, *Tsunami Inundation Map for Emergency Planning, Santa Cruz Quadrangle, State of California, County of San Mateo*, July 1, 2009.
- California Geological Survey (CGS) and USGS Quaternary Faults and Folds database: <http://geohazards.usgs.gov/qfaults/map.php>
- Dupre, W. R., *Maps Showing Geology and Liquefaction Potential of Quaternary Deposits in Santa Cruz County, California*, USGS Miscellaneous Field Studies Map MF-648, 1975.
- Graymer, R.W. et al, *Geologic Map of the San Francisco Bay Region*, USGS/CGS Scientific Investigations Map 2918, 2006
- Hart, E.W. and Bryant, W.A., *Fault-Rupture Hazard Zones in California*, CGS Special Publication 42, revised 2007.
- Jennings, C.W. and Bryant, W. A., *2010 Fault Activity Map of California*, CGS Geologic Data Map No. 6: <http://www.quake.ca.gov/gmaps/FAM/faultactivitymap.html>.
- Portland Cement Association, *Concrete Floors on Ground*, 2001.
- USGS, *Beta – Unified Hazard Tool*: <http://earthquake.usgs.gov/hazards/interactive/>
- USGS, *Quaternary Faults and Folds Database of the United States*: <http://earthquake.usgs.gov/hazards/qfaults/map/>
- USGS: *US Seismic Design Maps*: <http://earthquake.usgs.gov/hazards/designmaps/usdesign.php>
- Unpublished reports, aerial photographs and maps on file with Geocon.